

**USE
AND
MAINTENANCE
MANUAL**

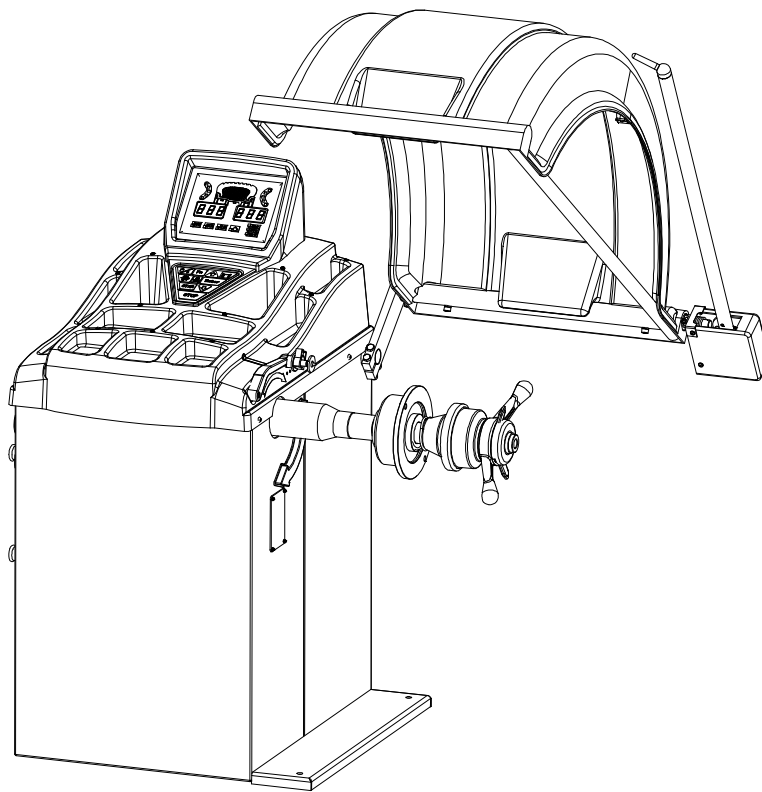

**WHEEL BALANCER
WITH MICRO-PROCESSOR**

GM-U96 PRO



PRINTING CHARACTERS AND SYMBOLS

Throughout this manual, the following symbols and printing characters are used to facilitate reading:

	Indicates the operations which need proper care
	Indicates prohibition
	Indicates a possibility of danger for the operators
BOLD TYPE	Important information

CONTENTS

1	INTRODUCTION	4
	1.1 INTRODUCTION	4
	1.2 MACHINE IDENTIFICATION DATA	4
	1.3 MANUAL KEEPING	4
2	GENERAL INFORMATION	5
	2.1 GENERAL SAFETY	5
	2.2 STANDARD SAFETY DVICES	5
	2.3 INTENDED USE	5
	2.4 GENERAL CHARATERISTICS	5
	2.5 MACHINE DESCRIPTION	6
	2.6 TECHNICAL SPECIFICATION	6
3	TRANSPORTATION, UNPACKING AND STORAGE	7
	3.1 TRANSPORTATION	7
	3.2 UNPACKING	7
	3.3 STORAGE	7
4	COMMISSIONING	8
	4.1 SPACE REQUIRED	8
	4.2 SHAFT ASSEMBLY	8
	4.3 WHEEL GUARD MOUNTING	9
	4.4 ELECTRIC CONNECTION	9
5	CONTROL PANEL AND MENU FUNCTION	10
	5.1. DISPLAY PANEL	11
	5.2 CONTROL PANEL	12
	5.3. MENU FUNCTIONS	
6	OPERATION OF THE WHEEL BALANCER	13
	6.1 BASIC OPERATION INFORMATION	13
	6.2 MOUNTING WHEEL ON SHAFT	13
	6.3 WHEEL DATA ENTRY	15
	6.4 BALANCING MODE	16
	6.4.1 DYNAMIC MODE	16
	6.4.2 STATIC MODE	16
	6.4.3. STANDARD ALU MODE	17
	6.4.4 ALU☆ MODE	18
	6.4.5 SPLIT FUNCTION	19
	6.4.6 UNBALANCE OPTIMIZATION (OPT)	20
7	SET UP	21
	7.1 SELF-DIAGNOSIS	21
	7.2 SELF-LEARNING	22
	7.3 CALIBRATION	22
8	MAINTENANCE	26
9	ERRORS AND TROUBLE-SHOOTING	27
10	ACCESSORIES	28
11	ELECTRIC DIAGRAM	29

CHAPTER 1 – INTRODUCTION

1.1 INTRODUCTION

Thank you for purchasing a product from the line of wheel balancer. The machine has been manufactured in accordance with the very best quality principles. Follow the simple instructions provided in this manual to ensure the correct operation and long life of the machine. Read the entire manual thoroughly and make sure you understand it.

1.2 MACHINE IDENTIFICATION DATA

A complete description of the “Wheel balancer model” and the “Serial number” will make it easier for our technical assistance to provide service and will facilitate delivery of any required spare parts. For clarity and convenience, we have inserted the data of your machine in the box below. If there is any discrepancy between the data provided in this manual and that shown on the name plate fixed to the wheel balancer, the latter should be taken as correct.

LOGO		
Type:		
Volt	Amp	Kw
Ph	Hz	
Year of manufacturing:		

1.3 MANUAL KEEPING

For a proper use of this manual, the following is recommended:

- Keep the manual near the lift, in an easily accessible place.
- Keep the manual in an area protected from the damp.
- Use this manual properly without damaging it.
- Any use of the machine made by operators who are not familiar with the instructions and procedures contained herein shall be forbidden.

This manual is an integral part of the manual: it shall be given to the new owner if and when the machine is resold.

	The illustrations have been made out of prototypes pictures. It is therefore possible that some parts or components of standard production differ from those represented in the pictures.
---	--

TO THE READER

Every effort has been made to ensure that the information contained in this manual is correct, complete and up-to date. The manufacturer is not liable for any mistakes made when drawing up this manual and reserves the right to make any changes due the development of the product, at any time

CHAPTER 2 – GENERAL INFORMATION

2.1 GENERAL SAFETY

- The wheel balancing machine should only be used by duly authorized and trained personnel.
- The wheel balancing machine should not be used for purposes other than those described in the instruction manual.
- Under no way should the wheel balancing machine be modified except for those modifications made explicitly by **THE MANUFACTURER**.
- Never remove the safety devices. Any work on the machine should only be carried out by specialist personnel.
- Avoid using strong jets of compressed air for cleaning.
- Use alcohol to clean plastic panels or shelves (AVOID LIQUIDS CONTAINING SOLVENTS).
- Before starting the wheel balancing cycle, make sure that the wheel is securely locked on the adapter.
- The machine operator should avoid wearing clothes with flapping edges. Make sure that unauthorized personnel do not approach the machine during the work cycle.
- Avoid placing objects inside the base as they could impair the correct operation of the machine.

2.2 STANDARD SAFETY DVICES

- Stop key for stopping the wheel under emergency conditions.
- A wheel guard of high impact plastic that is designed to prevent the counterweights from flying out in any directing except toward the floor.
- A switch interlock system prevents the machine from starting if the guard is not lowered and stops the wheel whenever the guard is raised.

2.3 INTENDED USE

- This wheel balancer has been designed and manufactured exclusively for balancing wheel with a maximum diameter of 1000mm and maximum weight of 65kg. The calibration system is sufficient to cover different wheels from motorcycles to cars.
- In particular **THE MANUFACTURER** cannot be held responsible for any damage caused through the use of wheel balancer for purposes other than those specified in this manual, and therefore inappropriate, incorrect and unreasonable.

2.4 GENERAL CHARATERISTICS

- Automatic measure of wheel distance and diameter
- Automatic weight positioning where the balancing weight has to be applied
- Automatic braking after spin
- Automatic start/stop when the hood is lowered/raised
- Automatic application of adhesive weights on unbalanced positions
- STOP pushbutton to stop the machine immediately
- Static and dynamic balancing modes
- Special balancing modes ALU, ALU☆
- Split function (or Hidden Weight) to hide the weights behind the spokes of rims
- Rapid optimization (OPT)
- Self-diagnosis

- Self-calibration
- Exceptional stability in reading the unbalance between planes
- Display in grams or ounces, in mm or inch
- Anchor-down installation unnecessary

2.5 MACHINE DESCRIPTION

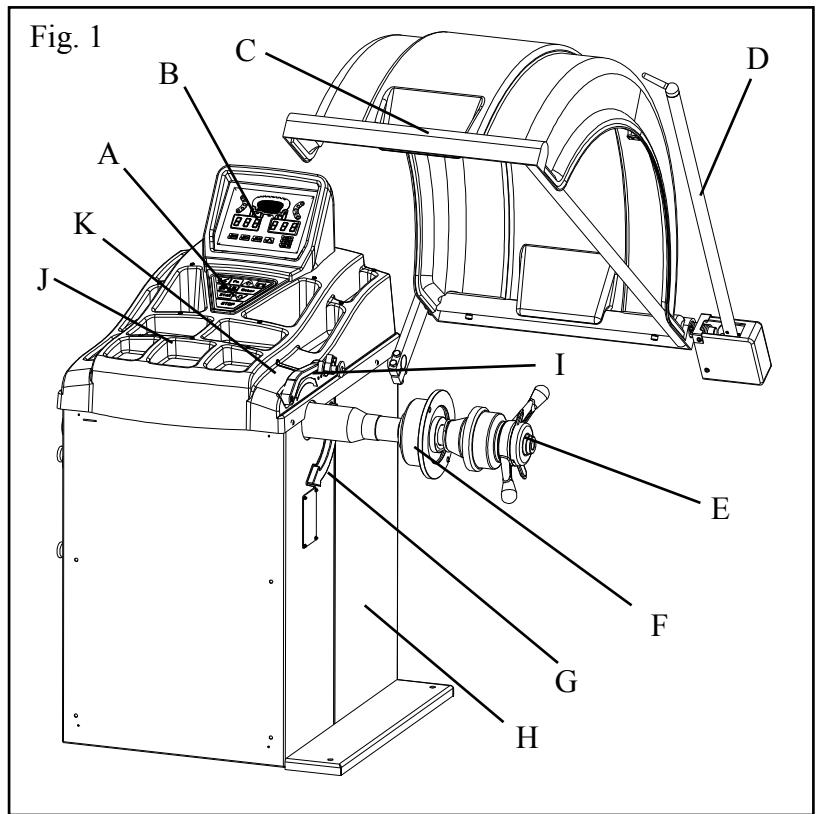

- A: Control panel
- B: Display panel
- C: Wheel guard
- D: Measuring gauge B (*)
- E: Quick locking nut
- F: Wheel shaft
- G: LED lighter
- H: Machine body
- I: Measuring gauge A/D
- J: Wheel weight tray/cover
- K: Laser pointer

(* Available only at request.

2.6 TECHNICAL SPECIFICATION

Max. wheel weight	65kg
Wheel diameter	39" (1000mm)
Rim diameter	10" - 26" (255 - 660mm)
Wheel width	1.5" - 20" (39 - 510mm)
Balancing precision	± 1g
Resolution	1.4 degrees
Cycle time	7 s
Max. balancing speed	150 rpm
Power supply	110V/220V/230V-1Ph
Motor power	90w
Noise level	< 70 dbA

CHAPTER 3 – TRANSPORTATION, UNPACKING AND STORAGE

3.1 TRANSPORTATION

- The machine must be transported in its original packaging and kept in the position shown on the package itself.
- The packaged machine may be moved by means of a fork lift truck of suitable capacity. Insert the forks at the points shown in figure 2.

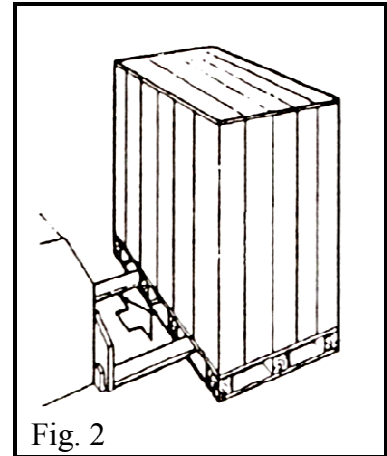

Fig. 2

3.2 UNPACKING

- Remove the protective cardboard and the nylon bag.
- Remove the fixing bolts from the packing pallet.
- Check that the equipment is in perfect condition, making sure that no parts are damaged or missing. Use fig. 1 for reference.



If in doubt do not use the machine and contact your retailer.

3.3 STORAGE

Packages must be stored in a covered place, out of direct sunlight and in low humidity, at a temperature between -10°C and $+40^{\circ}\text{C}$.

In the event of storage for long periods of time, be sure to disconnect all sources of power and grease the clamp sliding guides on the turntable to prevent them from oxidizing.

CHAPTER 4 – COMMISSIONING

4.1 SPACE REQUIRED



When choosing the place of installation, make sure that it complies with current safety at work regulations.

Do not operate the balancer while it is on the pallet.

- The balancer must be located on a flat floor of solid construction, preferably concrete. The balancer must sit solidly on its three feet. If the balancer is not leveled, the balancer will not function properly and may produce inaccurate balance readings.
- Select a location for the balancer that provides a level, solid floor, and adequate clearance around and above the balancer. The place of installation must also provide at least the space shown in pictures Fig. 3 and Fig. 4 so as to allow all parts of the machine to operate correctly and without any restriction.
- Make sure the location selected has enough room above and behind the machine so the wheel guard can be raised completely. The location must also provide working room for mounting and removing wheels. Make sure the area has adequate lighting.
- If the machine is installed outside it must be protected by a lean-to.

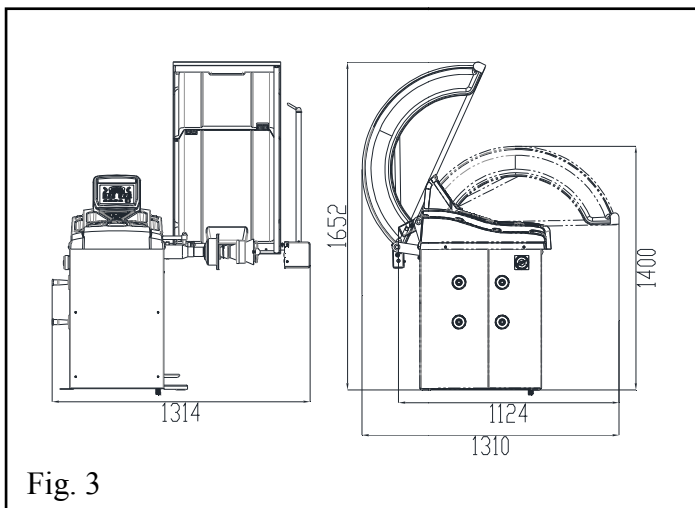

Fig. 3

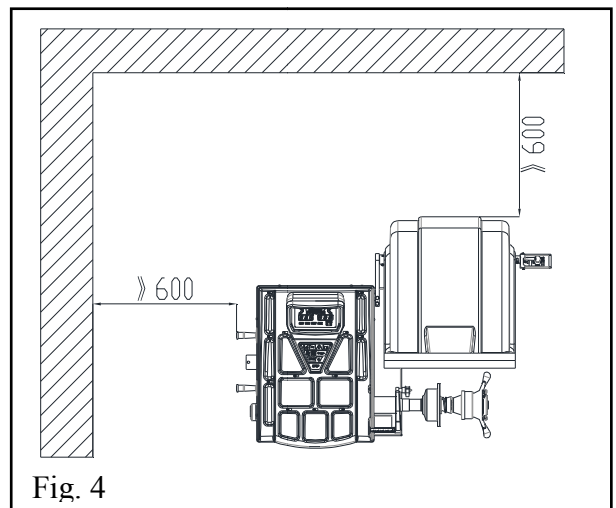

Fig. 4

4.2 SHAFT ASSEMBLY

- Mount the thread end piece (A) onto the shaft by screwing the retaining screw (B).
- Tighten the retaining screw (B) thoroughly by using the supplied wrench (C).

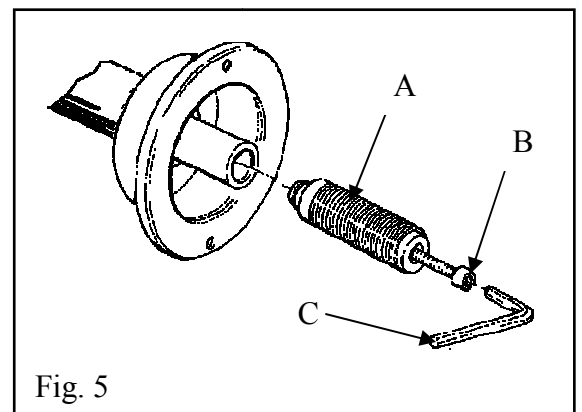
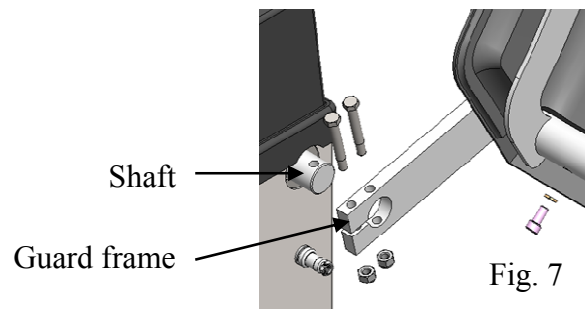
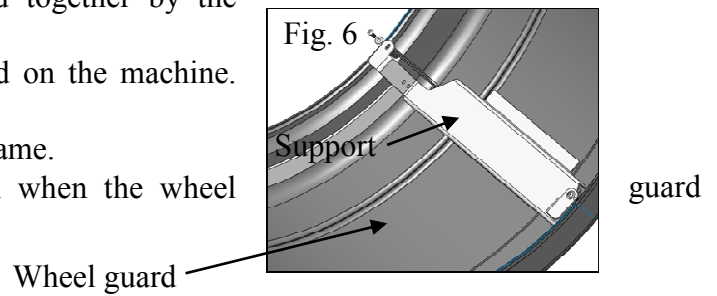

Fig. 5

4.3 WHEEL GUARD MOUNTING

- Connect two parts of the wheel guard together by the support and screws (ref. Fig. 6).
- Mount the guard frame onto shaft fixed on the machine. Tighten the screws (ref. Fig. 7).
- Mount the wheel guard onto the guard frame.
- Check the micro switch is held down when the wheel is closed. Adjust it if necessary.



	Do not clean on the guard during the wheel balancing cycle.
---	--

4.4 ELECTRIC CONNECTION

	<p>Any electric connection job must be carried out by professionally qualified personnel.</p> <p>Make sure that the power supply is right.</p> <p>Make sure the connection of the phases is right. Improper electrical hook-up can damage motor and will not be covered under warranty.</p>
---	--

- The machine is supplied with a single phase mains cable plus earth (ground)
- Check to make sure the characteristics of your systems correspond to those required by the machine. The supply voltage (and mains frequency) is given on the machine nameplate. It cannot be changed.
- Connect the machine to the main electric power supply. If the machine does not include the electric plug, the user must set one, which must conform to the voltage of the machine, in compliance with the regulations in force.
- The machine should not be started up without proper earthing.

CHAPTER 5 – CONTROL PANEL AND MENU FUNCTION

5.1. DISPLAY PANEL

Fig. 8 – DISPLAY PANEL

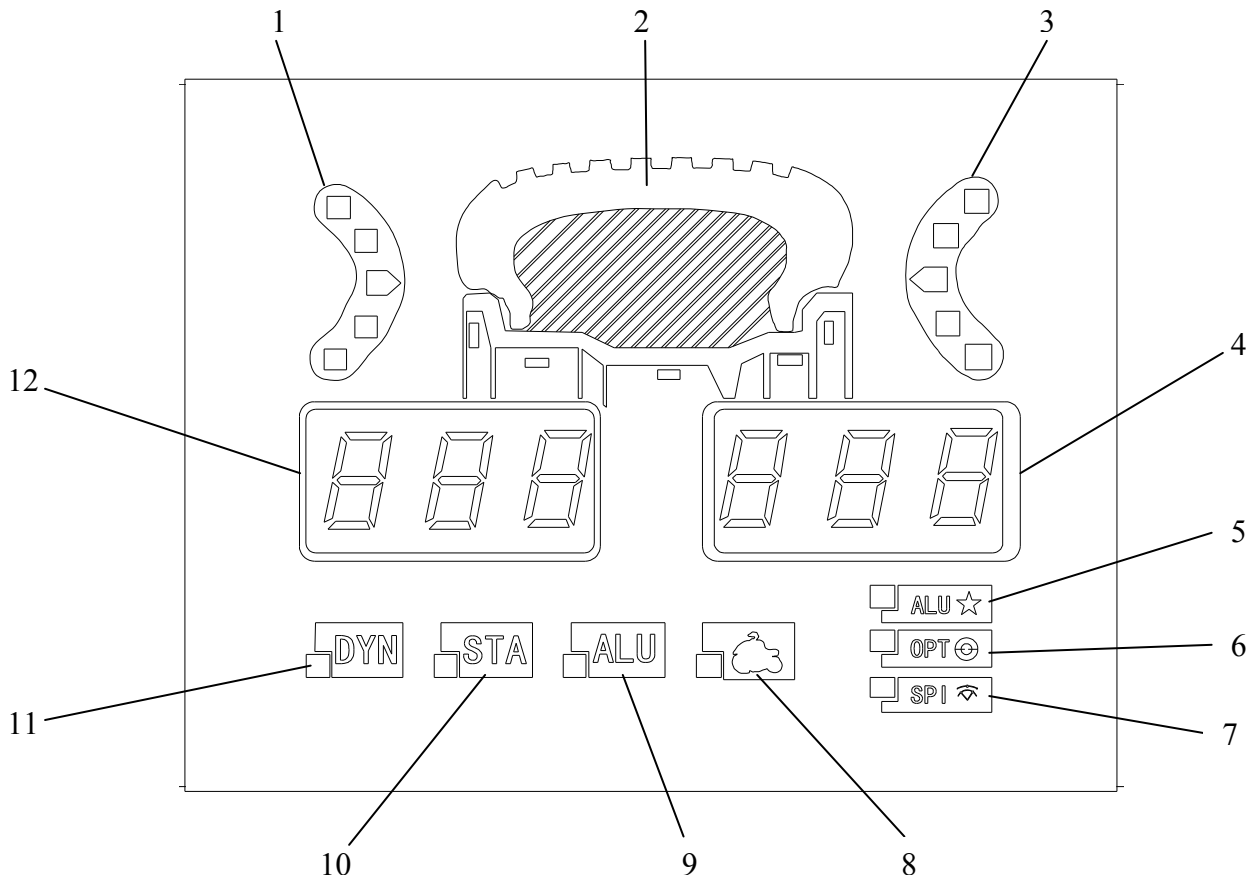

1. LED indicator, POSITION OF UNBALANCE inside
2. Indicators, position of application for correction weights
3. LED indicator, POSITION OF UNBALANCE outside
4. Digital readouts, AMOUNT OF UNBALANCE outside
5. Indicator, ALU ☆ mode selected
6. Indicator, OPT mode selected
7. Indicator, SPLIT mode selected
8. Indicator, MOTORCYCLE WHEEL mode selected
9. Indicator, ALU mode selected
10. Indicator, STATIC BALANCE selected
11. Indicator, DYNAMIC BALANCE selected
12. Digital readouts, AMOUNT OF UNBALANCE inside

5.2. CONTROL PANEL

	<p>Press buttons only with your fingers. Never use the counterweight pincers or other pointed objects.</p> <p>When the beep signal is enabled, pressing any push button is accompanied by a “beep”.</p>
---	---

Fig. 9 – CONTROL PANEL



1. Reading accuracy selection
2. Mode selection
3. Function selection “+”
4. Rim parameters selection
5. Confirm
6. Function selection “-”
7. Home/Emergency/Manual brake
8. Start
9. Setup MENU
10. SPLIT/OPT function

5.3 MENU FUNCTIONS (figure 10)

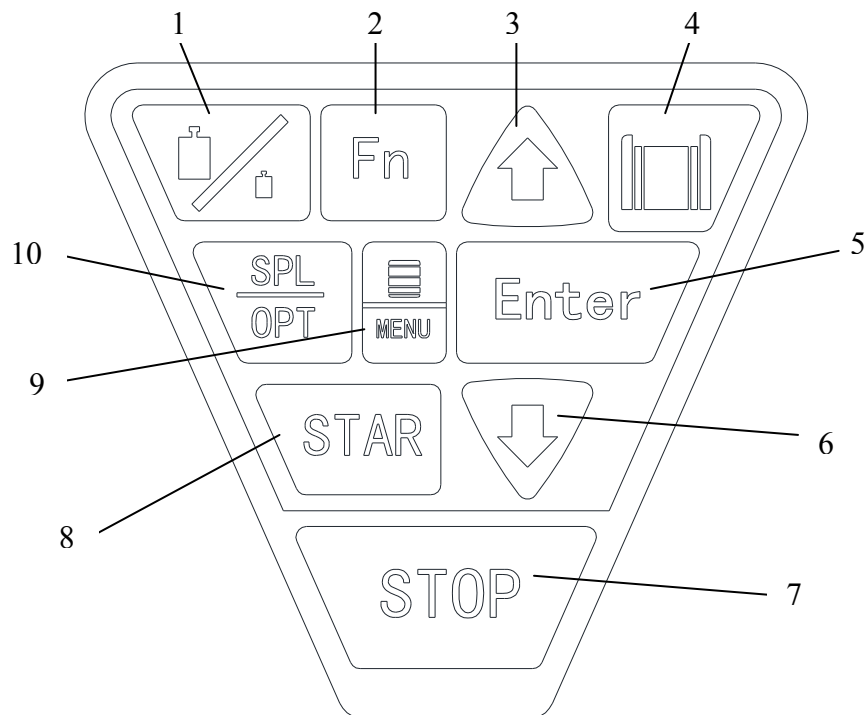
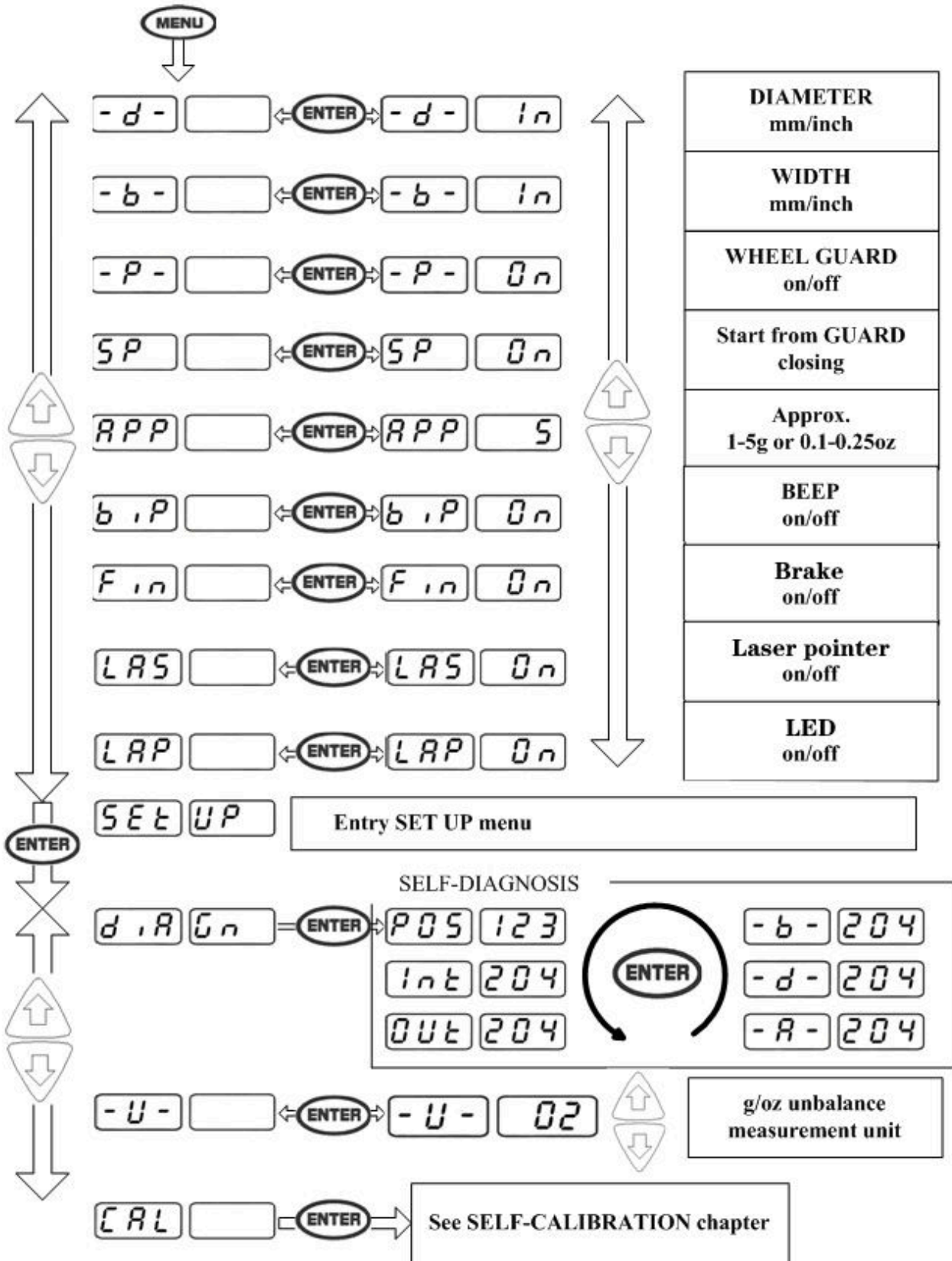

Press **STOP** to exit any function.

CHAPTER 6 – OPERATION OF THE WHEEL BALANCER

	<p>Do not use the machine until you have read and understood the entire manual and the warning provided.</p> <p>The wheel guard must not be opened before the wheel stops. The STOP button serves to stop the machine immediately in emergencies.</p> <p>Do not permit the control panel to get wet!</p>
---	---

	<p>Chains, bracelets, loose clothing or foreign objects in the vicinity of the moving parts can represent a danger for the operator.</p>
---	---

6.1 BASIC OPERATION INFORMATION

	<p>The initial screen when switching on is in DYNAMIC mode.</p> <p>LED lighter can be lit up or out at any time by pushing the keys “+” and “-” together.</p> <p>AUTOMATIC BRAKE can be available only when the function “wheel guard on” is enabled.</p>
---	--

- Mount the wheel on the shaft of machine. Use the most appropriate mounting method. Always remove any weight attached to the wheel.
- Switch on the machine.
- Measure and entry the wheel data.
- Select the most appropriate balancing mode. The initial screen is in DYNAMIC mode.
- Start the machine. Performing a spin can be started by pressing START button or closing the wheel guard if START FROM GUARD CLOSING is enabled.
- When the figures have been established, the wheel is automatically braked to a stop in the correction zone. After the spinning stops, the unbalanced amounts are shown on the digital readouts, and meanwhile the unbalanced LED indicator on the side with the maximum unbalanced value is lit up completely to indicate the correct angular wheel position to apply the counterweights.
- At the mode ALU2 or ALU3, if the unbalanced LED indicator on the inner side of the wheel is lit up completely after spinning, the laser pointer is lit and its beam points to the unbalanced position exactly on the inner side of the wheel, where the weights are to be applied for.
- Apply weights on the position (12 o'clock position) for correction.
- With the counterweights correctly in position, restart the machine to check the correct balancing of the wheel.
- Reset the balancing mode referring to the figure. 8.

6.2 MOUNTING WHEEL ON SHAFT

	<p>Avoid back injury, seek assistance when lifting a heavy wheel onto the balancer shaft.</p> <p>Make sure to tighten the quick locking nut. Failure to do so may result in serious personal injury.</p>
---	--

- Select the most appropriate mounting method for the wheel you are balancing. Using the proper method ensures secure mounting and safe balancer operation, and prevents damage to the wheel.
- On most wheels, the inner side of the wheel hub usually has the most uniform surface for wheel balancing. Always center the wheel by the most uniform shaped side of the hub to achieve the most accurate balance.
- Regardless of mounting type, always make sure that the wheel is forced firmly against the shaft faceplate and that the quick locking nut is tightened. To assist in centering the wheel properly, rotate the wheel and the shaft while tightening the nut.

6.2.1 STANDARD BACK CONE MOUNTING (ref. Fig. 11)



Most steel wheels can be mounted properly using this method. The wheel is centered on a cone from the inner side of the hub.

- Select the cone that best fits the centre hole in the wheels. Slide the cone onto the shaft with the large end towards the faceplate.
- Lift the wheel onto the shaft and centre it on the cone.
- Attach the pressure cup to the quick locking nut and install the assembly onto the shaft. Tighten securely.

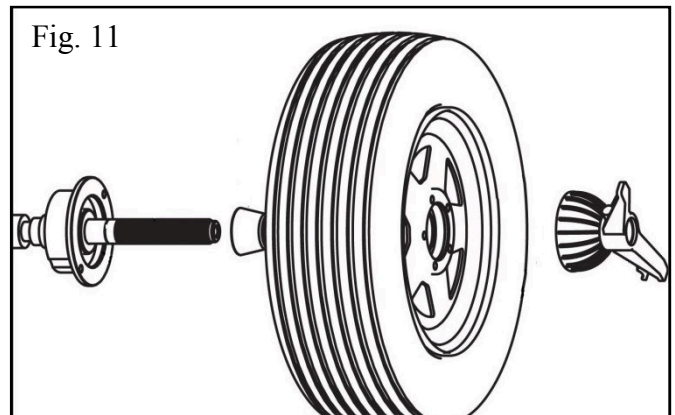

6.2.2 STANDARD FRONT CONE MOUNTING (ref. Fig. 12)

A wheel should be centered by the outer side of the hub only when the inner surface will not provide an accurate surface to center on.

- Select the cone that best fits the center hole in the wheel.
- Lift the wheel onto the shaft and slide it back against the shaft faceplate.
- Slide the cone onto the shaft and into the center of the wheel. You will need to lift the wheel to seat the cone in the center hole.
- Install the quick locking nut (without the pressure cup) onto the shaft. Tighten securely against the cone.

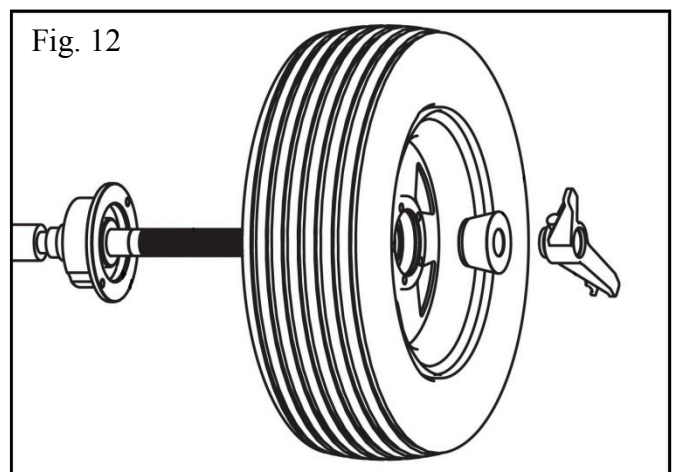

6.3 WHEEL DATA ENTRY

 Before balancing a wheel, wheel data must be entered.

For STANDAD MODES, measure the wheel dimensions as shown in the figure 13.

For ALU☆ MODE, measure the wheel dimensions as shown in the figure 14.

In this machine, A and D values also can be entered either manually or automatically.

Fig. 13 – STANDARD MODES

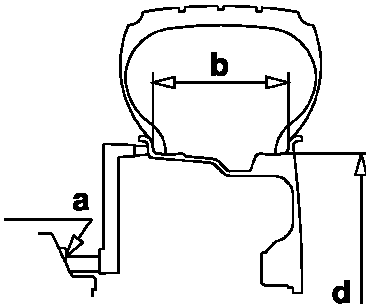
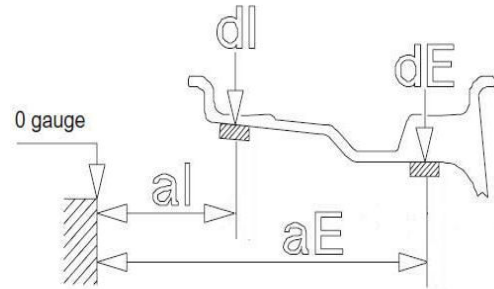

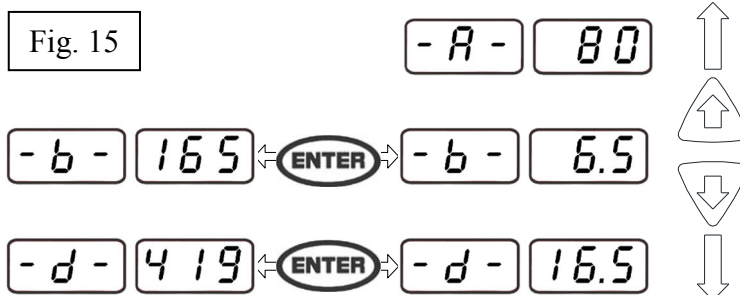

Fig. 14 – ALU☆ MODE



6.3.1 MANUAL ENTRY OF WHEEL DATA

To enter the values manually, press the key  , then follow the procedure shown in the figure 15.



6.3.2 AUTOMATIC ENTRY OF A/D

- Move the A/D gauge to measure the A and D dimensions automatically as shown in the figure 16, and meanwhile LED lighter is lit for 100 seconds.
- Once a dimension is determined, a beep sound can be heard.

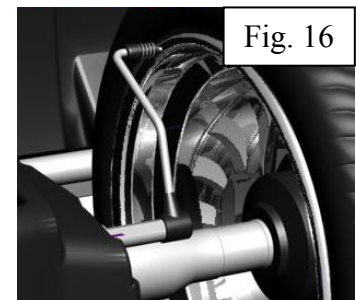

6.3.3 AUTOMATIC ENTRY B (if available)

- Move the B gauge to measure the B dimension as shown in the figure 17.
- Once the dimension is determined, a beep sound can be heard.

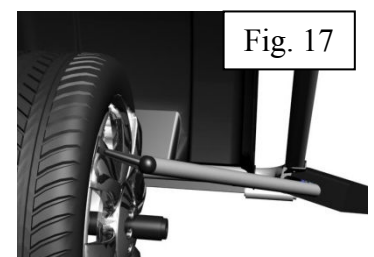



6.4 BALANCING MODE

	<p>With the function “wheel guard on” enabled, the wheel is automatically braked to a stop for 5 minutes at the unbalanced position exactly after spinning, where the weight is to be applied for.</p> <p>When rotating the wheel manually, the wheel can be braked at any position by pushing the key “STOP”.</p>
---	--

6.4.1 DYNAMIC MODE

The dynamic mode is used for most passenger and light truck wheels using the most common location for corrective weights. Clip-on weights are placed on the inner and outer sides of the rim.

- On the initial screen, press the key **START**  .
- With the function “wheel guard on” enabled, the wheel can be automatically braked to a stop at the first unbalanced position after spinning, where the weights are to be applied for.
- After the weights are applied on the first unbalanced position, press **START** to rotate the wheel automatically to the second unbalanced position for application of the weights.

Correction of outer side

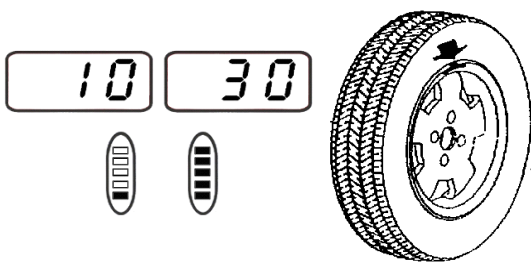

Correction of inner side

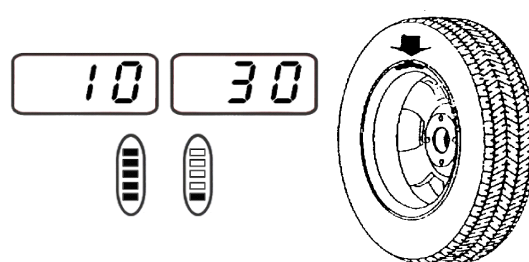





Fig. 18

6.4.2 STATIC MODE

The static mode is used for motorcycles or narrow wheels when it is not possible to place the counterweights on both sides of the rim. Clip a single weight on one of sides of the rim or in centre of wheel according to the diameter of the wheel mounted.

- Press the key **F_n** to select “Static Mode” till the indicators **STA** and  are lit up.
- Press the key **START**  .
- With the function “wheel guard on” enabled, the wheel is automatically braked to a stop at the unbalanced position after spinning, where the weights are to be applied for.

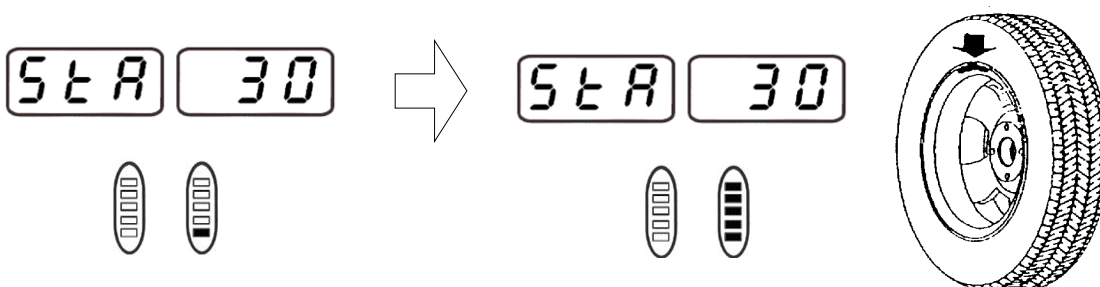



Fig. 19

6.4.3 STANDARD ALU MODE

All the ALU modes are for dynamic balance. Choose the option that best fits the available locations as shown in the figure 20.

On the measurement screen, press the key  to select the modes ALU1 or ALU2 or ALU3 or ALU4, then start the spin.

- With the function “wheel guard on” enabled, the wheel is automatically braked to a stop at the first unbalanced position after spinning, where the weights are to be applied for.

	<p>At the mode ALU2 or ALU3, if the unbalanced LED indicator on the inner side of wheel is lit up completely after spinning, the laser pointer is lit and its beam points to the unbalanced position on the inner side of the wheel, where the weights are to be applied for.</p> <p>Hidden adhesive weights can be applied by the pusher on the automatic distance gauge.</p>
---	--



- After the weights are applied on the first unbalanced position, press  to rotate the wheel automatically to the second unbalanced position for application of the weights.

Fig. 20



	<p>Hidden adhesive weights can be applied by the pusher on the automatic gauge, as shown in the following.</p>
---	---

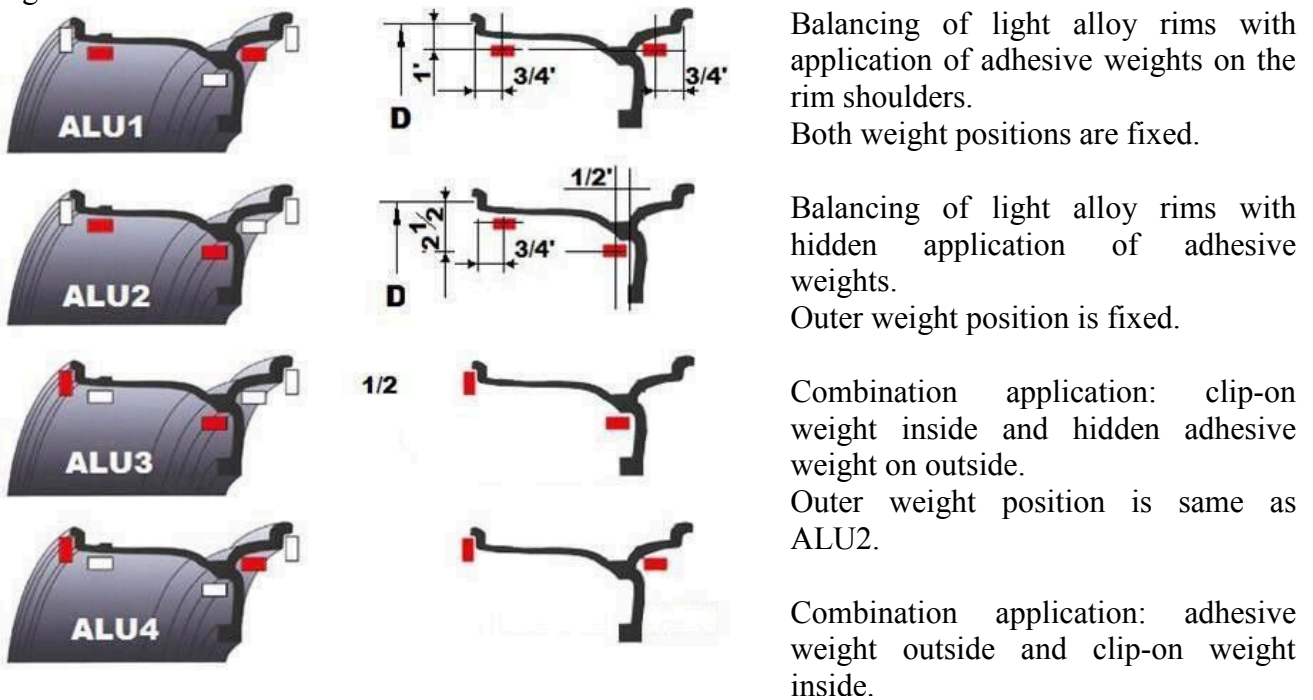

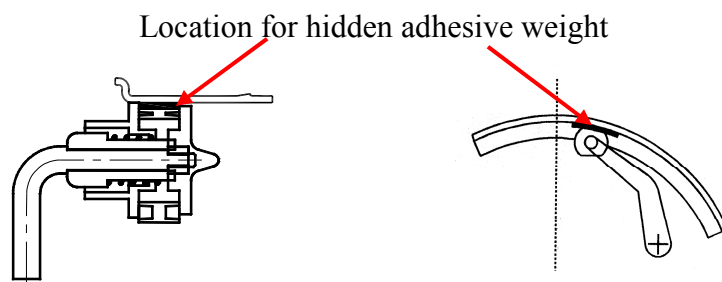
6.4.4 ALU☆ MODE

This is a special ALU mode for precise and fast application of the adhesive weights on the rim by means of the automatic gauge.

- Select ALU☆ mode.
- Choose two positions on the rim where can be applied with the adhesive weights and then measure the dimensions as shown in the figure 21. Pay attention to press ENTER to memorize A1 dimension which must be measured at first, then measure AE dimension that is memorized automatically.

Fig. 21

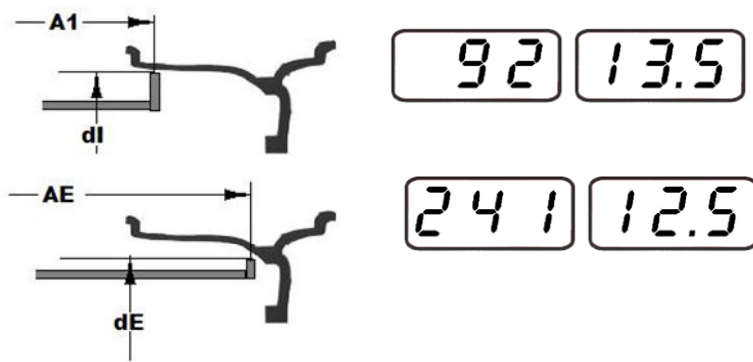

For an example

A1 = 92

AE = 241

dI = 13.5

dE = 12.5

- Start the spin.
- After performing the balancing spin, pull the distance gauge to the inner and outer position separately until “0” is shown on the digital readouts, where to apply the adhesive weights.

Fig. 22

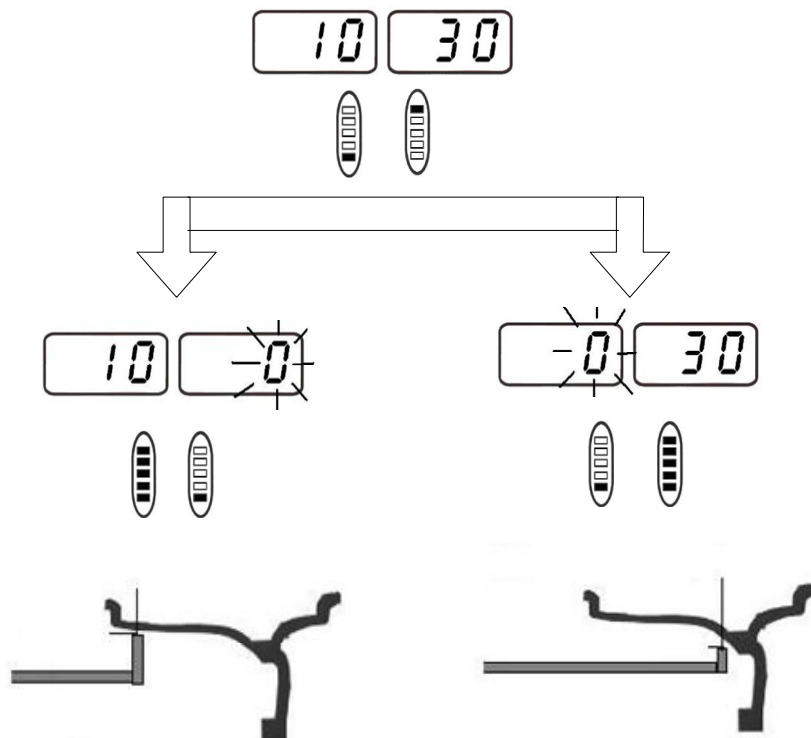

6.4.5 SPLIT FUNCTION

The SPLIT function is used to position the adhesive weight behind the wheel spokes so that they are no longer visible. It is advisable to use this function only in the event static unbalance or in the ALU☆ mode. Input the wheel data and start the spin. To start the SPLIT function, in the following data for an example:

Fig. 23

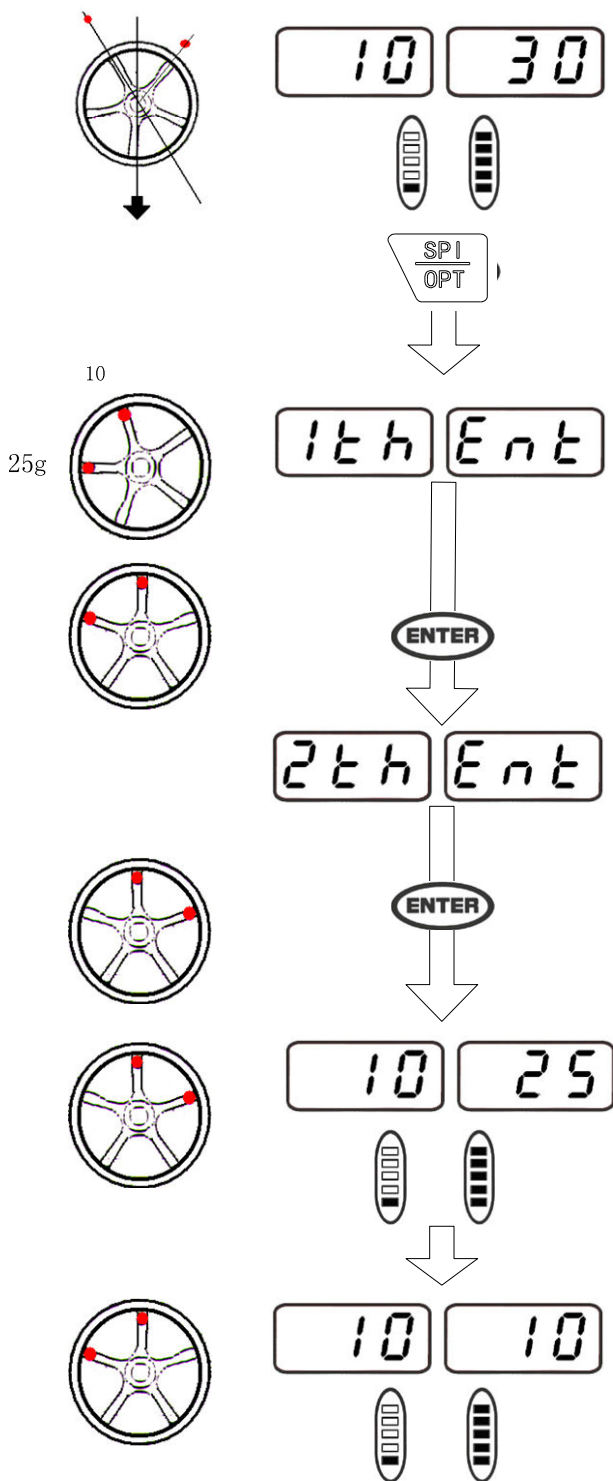

At ALU☆ mode, the unbalanced amount of the outer side of the rim shown on the digital readouts is 30g.

Choose the first spoke of two adjacent spokes. Rotate the wheel to move the first spoke to 12 o'clock position.

Press **ENTER** to memorize the position.

Choose the second spoke of two spokes. Rotate the wheel to move the second spoke to 12 o'clock position.

Press **ENTER** to memorize the position.

Move the first spoke back to the memorized position. Brake the pedal and then apply the adhesive weights on the position according to the unbalanced amounts shown on the digital readouts.

Move the second spoke back to the memorized position. Brake the pedal and then apply the adhesive weights on the position according to the unbalanced amounts shown on the digital readouts.





To exit SPLIT function, press **SPLI OPT** and then **STOP**.

6.4.6 UNBALANCE OPTIMIZATION (OPT)

This function is used to determine the best mating of tire and rim that will result in the least amount of total unbalance of the wheel. It serves to reduce the amount of weight to be added in order to balance the wheel. It is suitable for static unbalance exceeding 30g.

	A high unbalance may indicate the improper mounting of the wheel on the balancer. If the unbalance is excessive, it may be prudent to replace the rim, the tire, or both. If either is replaced, do not continue with optimization. Balance the new tire and rim and evaluate the readings.
---	--

After performing the static balance, press . If the unbalance amount shown on the digital readouts is exceeding 30g, the digital readouts display “YES” “OPT”. In this case, start OPT function:

- Mark with chalk reference points on the same position of both the tire and the rim.
- Rotate the wheel to move the marked points to 12 o'clock position.
- Press  to memorize the position.
- Remove the wheel from the balancer.
- Remove the tire from the rim with the aid of a tire changer.
- Only mount the rim on the balancer.
- Rotate the rim to move the mark to 12 o'clock position.
- Press   .
- Press  to spin the rim.

After performing the spin:

- Rotate the rim until LED indicator for outside lights up.
- Mark with chalk on the rim at 12 o'clock position.
- With the aid of the tire changer, refit the wheel with the reference marks coinciding between the rim and tire.

CHAPTER 7 – SET UP

7.1 SELF-DIAGNOSIS

Fig. 24

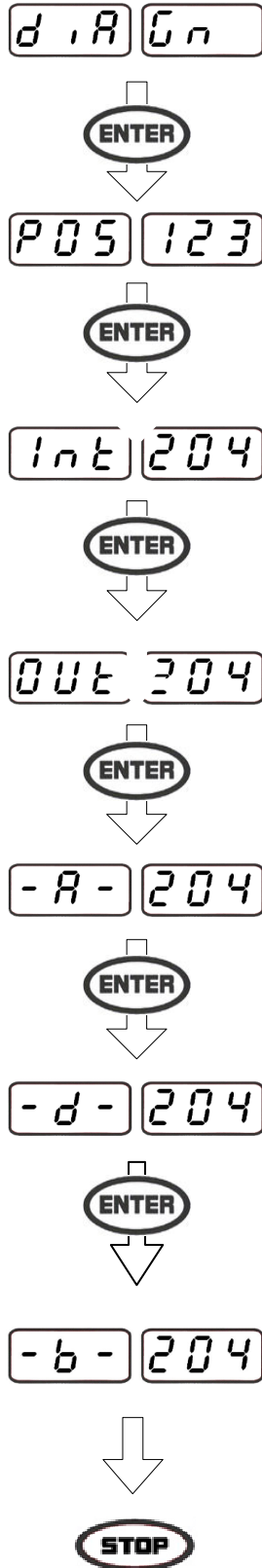

Diagnosis of phase



Rotate the wheel in direction of rotation, the readouts display from 0 to 255.

Rotate the wheel in reverse direction of rotation, the readouts displays from 255 to 0.

Diagnosis of inner piezo

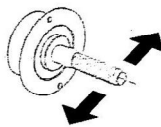

Push the balancing shaft from any direction, the readouts change.

Diagnosis of outer piezo

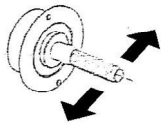

Push the balancing shaft from any direction, the readouts change.

Diagnosis of distance “A” potentiometer

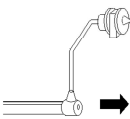

Pull the gauge index gradually, the readouts change.

Diagnosis of diameter “D” potentiometer

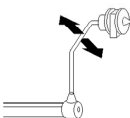

Rotate the gauge index, the readouts change.

Diagnosis of diameter “B” potentiometer

Move the gauge from “0” position to the shaft flange, the readouts change.

Press **STOP** to end SELF-DIAGNOSIS,

7.2 SELF-LEARNING

This function is designed to ensure that every wheel to be balanced can be automatically braked exactly at the unbalanced position after the spin is completed.

In case that a wheel cannot be automatically braked at the proper position, do as follows:

- Switch off the machine.
- Fix the wheel to be balanced in the machine properly.
- Keep pressing the key “STOP” and switch on the machine in the meantime.
- Enter the wheel data A, D and B.
- With the function “wheel guard on” enabled, lower down the wheel guard to start the spin.
- After the spin is completed, check if the wheel is braked to a stop exactly at the unbalanced position when the unbalanced indicator on one side (where the maximum unbalanced value exists) is lit up completely.
- If not, repeat above procedures until the wheel can be braked exactly at the unbalanced position.
- Press “MENU” button two times to memorize.
- Switch off the machine to exit.

7.3 CALIBRATION

To access SELF-CALIBRATION menu referring to the figure 8.

To select the different calibration procedures as follows:

Fig. 25

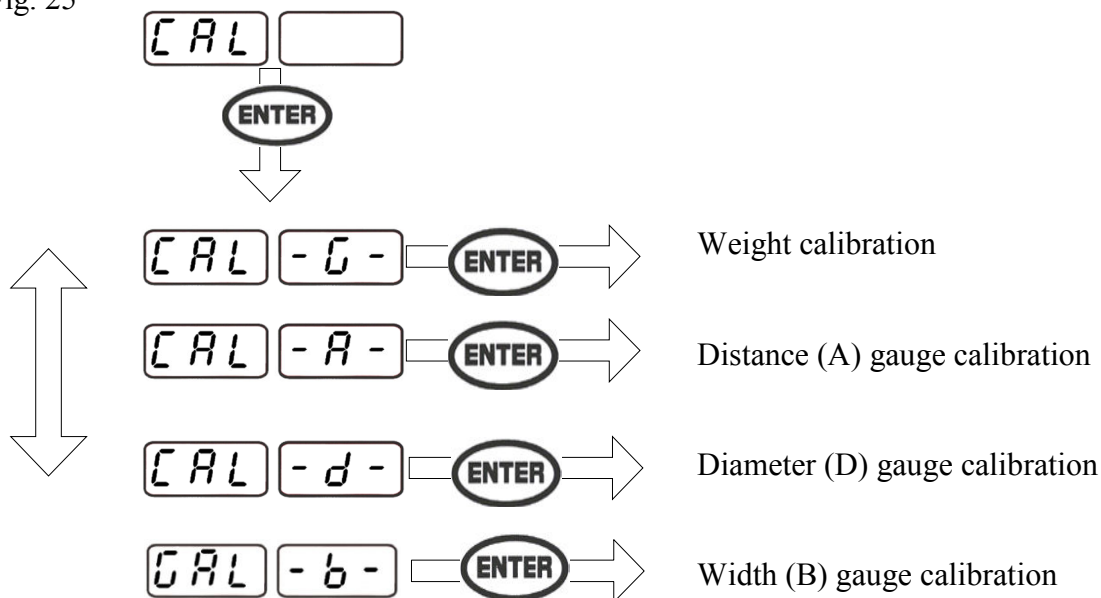

7.3.1 WEIGHT CALIBRATION

	<p>Make sure to enter the exact date of the wheel mounted. Entry of incorrect data would mean that the machine is not correctly calibrated, therefore all subsequent measurements will be incorrect until the new self-calibration is performed with the correct data.</p>
---	---

Fig. 26



Mount a wheel with average data on the shaft.
 Enter the exact data of the wheel mounted.

Perform the first spin under normal condition

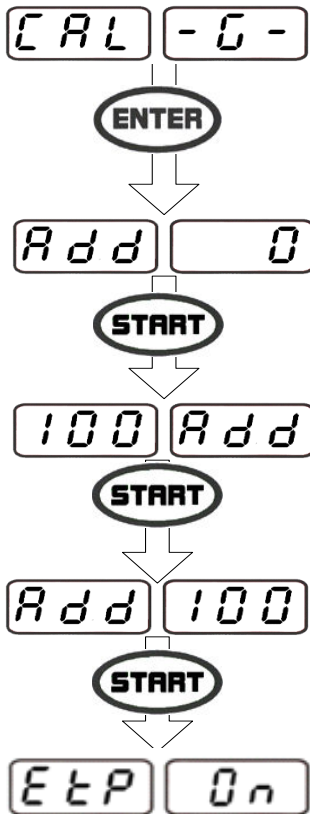
Rotate the wheel manually to 12 o'clock and apply 100g weight on the inner side of the rim.
 Start the second spin.

After the second spin, rotate the wheel manually to 12 o'clock, then remove the 100g weight applied on the inner side of the rim and apply 100g weight on the outer side of the rim.

Start the third spin.
 After the spin, **E t P 0 n** flashes seconds to exit the weight calibration automatically.
 Remove the 100g weight from the wheel.

7.3.2 CALIBRATION OF A GAUGE

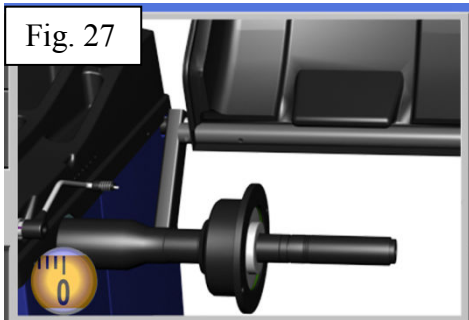

Fig. 27

Set the gauge on “0” position..

Press **ENTER** to memorize “0” position”.

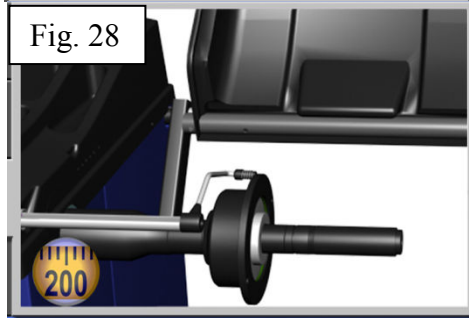

Fig. 28

Set the gauge at the distance 200mm.

Press **ENTER** to memorize.

7.3.3 CALIBRATION OF D GAUGE

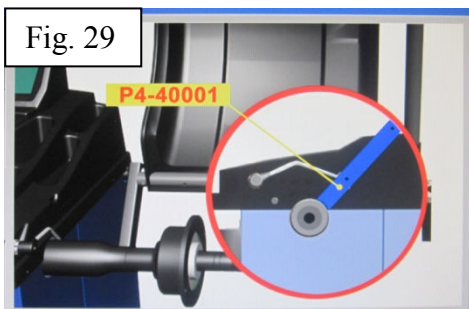

Fig. 29

Place the supplied calibration meter on the HIGER PROFILE surface of shaft (“0” position) and then set the gauge tip into the lower hole of the meter.

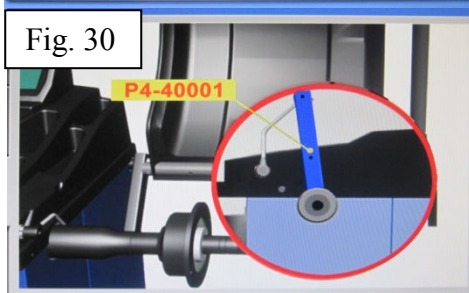

Fig. 30

Place the supplied calibration meter on the HIGER PROFILE surface of shaft (“0” position) and then set the gauge tip into the upper hole of the meter (“200” position)

Press **ENTER** to memorize.

To exist, press **STOP**.

7.3.4 CALIBRATION OF B GAUGE (if available)

Fig. 31

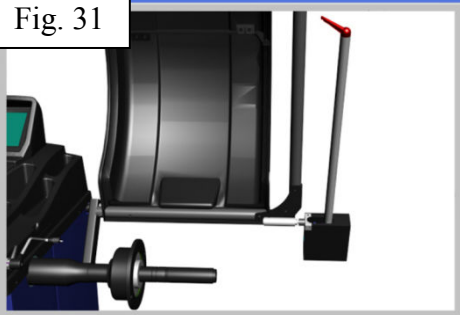

Place the gauge to the “0” position.

Press **ENTER** to memorize.

Fig. 32

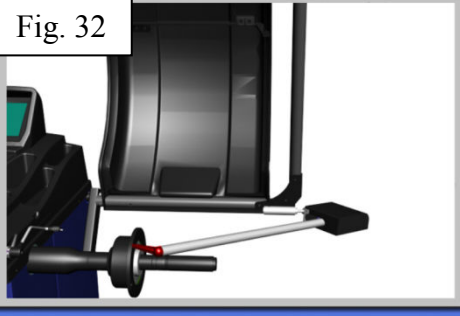

Set the gauge head to the outer surface of the shaft flange.

Press **ENTER** to memorize.

To exist, press **STOP** .

CHAPTER 8 – MAINTENANCE

8.1 GENERAL WARNINGS



Unauthorized personnel may not carry out maintenance work.

- Regular maintenance as described in the manual is essential for correct operation and long lifetime of the machine.
- If maintenance is not carried out regularly, the operation and reliability of the machine may be compromised.



Before carrying out any maintenance work, disconnect the electric supply.



Do not clean the machine with compressed air or jet of water.

- Defective parts must be replaced exclusively by expert personnel using the manufacturer's parts.
- Removing or tampering with safety devices is extremely forbidden.



In particular, the Manufacturer shall not be held responsible for complaints deriving from the use of spare parts made by other manufacturers or for damage caused by tampering or removal of safety systems.

8.2 ORDINARY MAINTENANCE

This balancer requires only minor maintenance to keep the machine operating properly.

- Keep the area around the machine clear.
- Keep the display clean and clear. Use a vaporizing cleaner only. Do not use cleaners or the solvents which leave oil or firmly residues behind.
- Keep the adaptors, cones, thread shaft, pressure cup, and the quick locking nut clean. Grease and dirt buildup will cause inaccurate balancing and premature wear. Clean these items at once a day using a vaporizing solvent.
- Clean the weight tray, the cone holders and accessories using a vaporizing solvent. Weights stored in a dirty tray may pick up grease and dirt which may keep them from attaching to the wheel securely.

CHAPTER 9 – ERRORS AND TROUBLE-SHOOTING

9.1 ERROR DISPLAY

During machine operation, various cause of faulty operation can occur. If defected by the micro-processor, they appear on the display as follows:

ERRORS:	MEANING:	SOLUTION:
Err -0-	The machine is not preset up by the manufacturer before delivery.	Call for the technical service.
Err -CAL-	Faulty calibration.	Recalibration.
Err -2-	Speed too low during balancing measurement spin.	Check the driven belt Check the bearings Check the motor Check the quick locking nut tightness
Err -5-	Micro switch is not adjusted properly or defective.	Check and adjust it or replace it if necessary.
Err -6-	The balancing measurement spin is stopped by carelessness.	

9.2 TROUBLE-SHOOTING

TROUBLE:	POSSIBLE CAUSE:	SOLUTION:
No display when switching on	<ol style="list-style-type: none"> 1. There is no power. 2. The faulty power plug. 3. The electrical wires are disconnected. 4. Wrong power voltage. 5. Fuses are blown. 	<ol style="list-style-type: none"> 1. Check power on. 2. Replace. 3. Reconnect. 4. Check for correct voltage. 5. Replace.
The diameter measured is not correct.	<ol style="list-style-type: none"> 1. The gauge is not positioned correctly when measuring. 2. The gauge is not calibrated. 	<ol style="list-style-type: none"> 1. Position the gauge correctly. 2. Calibrate the gauge.
The measurement gauge cannot function properly.	<ol style="list-style-type: none"> 1. The gauge fails to return onto its original position automatically. 	<ol style="list-style-type: none"> 1. Reset the gauge. 2. Switch off and switch on the machine again
The machine does not spin when the wheel guard is closing.	<ol style="list-style-type: none"> 1. The function “start from the guard closing” is not enabled. 2. The wheel guard is not closed completely. 3. The electric wire for the micro switch is disconnected. 4. The micro switch is not adjusted properly or faulty. 	<ol style="list-style-type: none"> 1. Enable the function if necessary. 2. Close the guard completely. 3. Reconnect. 4. Check for correct adjustment or replace it if necessary.
Inconsistent unbalance reading	<ol style="list-style-type: none"> 1. The machine is shocked. 2. The machine is not rested solidly. 3. The wheel is not tightened. 4. Wrong data entry. 5. The machine is not calibrated. 	<ol style="list-style-type: none"> 1. Do not shock the machine and restart a spin. 2. Sit the machine solidly. 3. Tighten the wheel. 4. Entry the correct data. 5. Calculate the machine.

CHAPTER 10 – ACCESSORIES

10.1 STANDARD ACCESSORIES

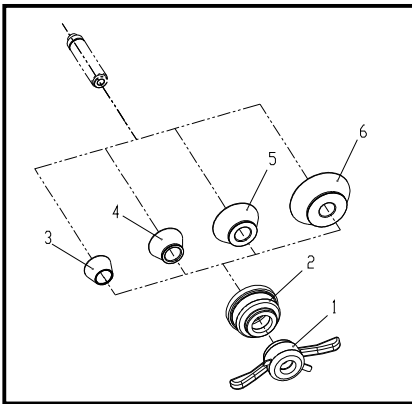

1. TR40X3 Quick locking nut
2. Pressure cup
3. P1-12001 Cone D.46-68
4. P1-12002 Cone D.55-87
5. P1-12003 Cone D.73-117
6. P1-12004 Cone D.102-154

10.2 OPTIONAL ACCESSORIES

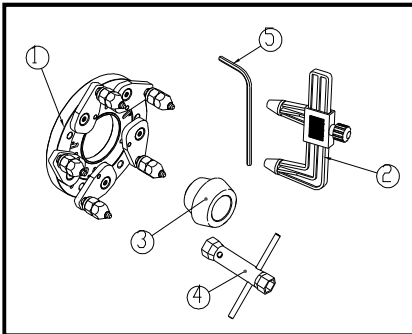

PF-211 Universal flange

Universal flange for wheels with/without central hole, suitable for any vehicle wheel with 3-4-5 holes.

1. Complete flange
2. Holes detector
3. Pre-centering cone
4. T-hexagonal wrench
5. Hexagonal elbowed wrench

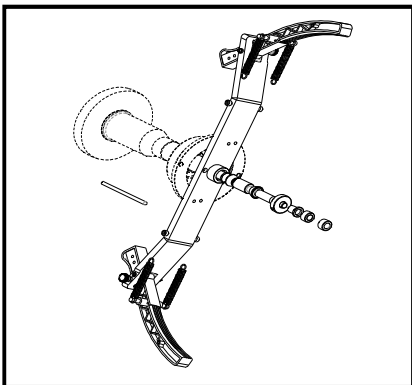

PF-810 Motorcycle adaptor.

1. PF-141 Kit of adaptors
2. P08AG Wheel clamp kit
3. PF-100001 Distance extension

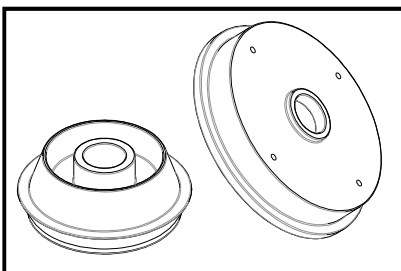

Light truck adaptor

1. PF-221201 Spacer
2. PF-221202 Cone D.111-165

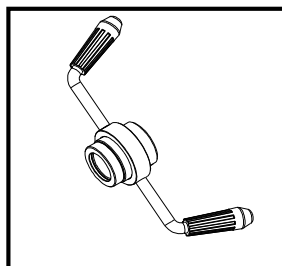

P3-61000

Heavy locking nut

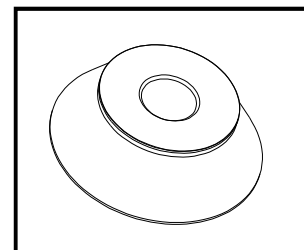

P1-12004W

4WD Cone D.95-132

CHAPTER 11 – ELECTRIC DIAGRAM

