

CATALOGUE

1. Introduction.....	1
2. Specification and Features	1
2.1 Specification	1
2.2 Features.....	1
2.3 Working Environment	1
3. The Constitution of Dynamic Balancer.....	2
3.1 Machine	2
3.2 Electricity system	2
4. Installation of Dynamic Balancer	2
4.1 Opening and Checking.....	2
4.2 Installing machine	3
4.3 Installing hood	3
4.4 Installing screw stud of drive shaft.....	3
5. LED control panel and function keys.....	3
5.1 LED display content	3
5.2 LED signification	4
5.3 Function key signification.....	4
6. Installation and Demounting of the Wheel	5
6.1 Checking the wheel	5
6.2 Installing the wheel.....	5
6.3 Demounting the Wheel.....	6
7. The input methods of date of rim	6
7.1 The power-on state of the machine.....	6
7.2 Date input method for normally dynamic balance mode	6
7.3 The date input method of ALU-S mode:	7
8. Calibration of measure scale.....	8
8.1 Calibration of rim distance scale.....	8
8.2 Calibration of diameter scale.....	9
8.3 Calibration of width scale	9
9. The Self-calibrating of Balancer.....	10
10. The Balancing Operation of Wheel	10
10.1 Balance mode change operation.....	10
10.2 Normal balance mode operation process.....	11
10.3 ALU-S balance mode operation process	12
★ Process of manual stickup counterweight.....	12
★ process of automatic stickup partition Counterweight	12
10.4 The operation process of M1 to M3 mode	13
10.5 Static balance (ST) operation process.....	13
10.6 The of Counterweight Hide-Stick mode.....	13
★ Split manual stick operation.....	14
★ Split automatic stick operation	14
10.7 Recalculation	14
11. Imbalance optimize	14
12. Gram and Oz conversion operation	15
13. INCH and MM conversion operation	16
14. Protect hood function and settings	16
15. Other function settings	16
15.1 Minimum value display settings.....	16

15.2 Key-tone clue on function settings 17

15.3 Display monitor brightness settings..... 17

15.4 Width automatic measure settings 17

16. Machine self test function..... 17

 16.1 LED and indicator light check 18

 16.2 Position sensor signal check 18

 16.3 Distance sensor signal check..... 18

 16.4 Diameter sensor signal check 18

 16.5 Width sensor signal check..... 18

 16.6 Pressure sensor signal check 19

17. Safety Protection and Trouble Shooting 19

 17.1 Safety protection 19

 17.2 Trouble shooting 19

18. Maintenance 20

 18.1 The daily maintenance of non- professionals 20

 18.2 The maintenance of professionals..... 21

19. Trouble-error code list 22

20. Power supply layout diagram..... 23

 20.1 220 V Connection..... 23

 20.2 380 V Connection..... 23

21. Exploded drawings..... 24

22. Spare parts list..... 28

 S Version Exploded drawings and spare parts list..... 29

 Accessories list 30

 Attach figure 1 System circuit diagram 31

1. Introduction

An imbalanced wheel will make the wheel jump and steering wheel wobble while driving. It can baffle the driver to drive, aggrandize the cleft of combine area of steering system, damage the vibration damper and steering parts, and increase the probability of the traffic accidents. A balanced wheel will avoid all these problems.

This equipment adopts the new LSI (Large Scale Integrated circuit) to constitute the hardware system that acquires processes and calculates information at a high speed.

Read the manual carefully before operating the equipment to ensure normal and safe operation. Dismantling or replacing the parts of equipment should be avoided. When it needs repairing, please contact with technique service department. Before balancing, ensure the wheel fixed on the flange tightly. Operator should wear close-fitting smock to prevent from hanging up. Non-operator does not start the equipment.

No use while beyond the stated function range of manual.

2. Specification and Features

2.1 Specification

Max wheel weight: 65kg
Motor power: 200W
Power supply: 220V/50Hz
Balancing precision: $\pm 1g$
Rotating speed: 200r/min
Cycle time: 8s
Rim diameter: 10"~24"(256mm~610mm)
Rim width: 1.5"~20"(40mm~510mm)
Noise: <70dB
Net weight: 105kg
Dimensions: 960mm×760mm×1160mm

2.2 Features

Adopt 9 LED display, it has flexible indicator operating function.

Various balancing modes can carry out counterweights to stick, clamp, or hidden stick etc.

Input data of rim automatically by measure scale.

Intelligent self-calibrating and measure scale self-labeling function.

Self fault diagnosis and protection function.

Applicable for various rims of steel structure and duralumin structure.

2.3 Working Environment

Temperature: 5~50°C

Height above sea level: $\leq 4000m$

Humidity: $\leq 85\%$

3. The Constitution of Dynamic Balancer

Two major components of the dynamic balancer are: machine and electricity:

3.1 Machine

The part of machine consists of support, swing support and main shaft; they are together fixed on the frame.

3.2 Electricity system

1. The microcomputer system is made up of the LSI such as new high speed MCU CPU system and keyboard.
2. Automatic measure scale.
3. Testing speed and positioning system consists of gear and opto-electronic coupler.
4. Two-phase asynchronous motor supplies and control circuit.
5. Horizontal and vertical pressure sensor.
6. Hood protection.

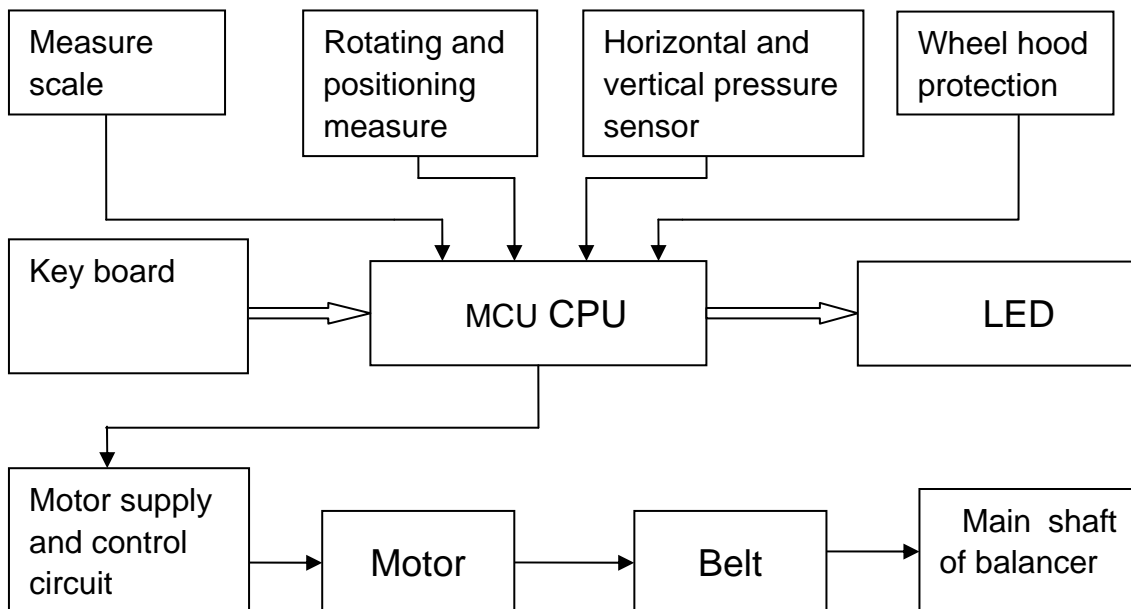

Figure 3-1

4. Installation of Dynamic Balancer

4.1 Opening and Checking

Open the package and check whether there are damaged parts. If there are some problems, please do not use the equipment and contact with the supplier. Standard accessories with equipment are shown as follow:

Screw stud of drive shaft	1
Balancing pliers	1
Allen wrench	1
Measure caliper	1
Locking nut	1

Adapter (cone)	4
Counterweight (100g)	1
Protection hood	1

4.2 Installing machine

4.2.1 The balancer must be installed on the solid cement or similar ground, unsolidified ground can bring measuring errors.

4.2.2 There should be 50cm around the balancer in order to operate conveniently.

4.2.3 Nail anchor bolts on the base's mounting hole of balancer to fix the balancer.

4.3 Installing hood

Install the frame of hood on the equipment (optional): plug the pipe of protection hood into the hood shift (behind the cabinet), then fix with M10×65 screws.

4.4 Installing screw stud of drive shaft

Install screw stud of drive shaft on the main shaft with M10 × 150 socket bolt, then screw down the bolt. (Refer to figure 4-1)

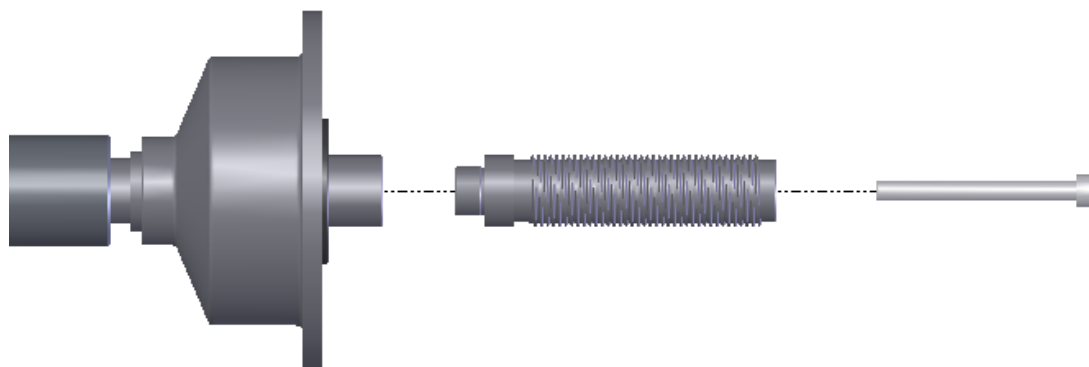

Figure 4-1

(**Notice:** a wheel can be installed on the main shaft before screwing down, then hold the wheel by hands in order to prevent the main shaft revolving together with the bolt.)

5. LED control panel and function keys

5.1 LED display content

LED 5: when you input dimension date, LED will display 'a' value; and when you after measure will display inside imbalance weight

LED 6: when you input dimension date, LED will bases differ mode display 'b' value or 'aE' value, and when function setting will display select menu

LED 7: when you input dimension date, LED will display 'd' value; and when you after measure will display outside imbalance weight

Part name of control panel

1. Balance mode indicator light
2. Inside stick position indicator light
3. LED 6 display content light

4. Outside stick position indicator light
5. LED 5
6. LED 6
7. LED 7
8. Inside balance weight position light
9. Outside balance weight position light

Figure 5-1 displaying on the LED control panel

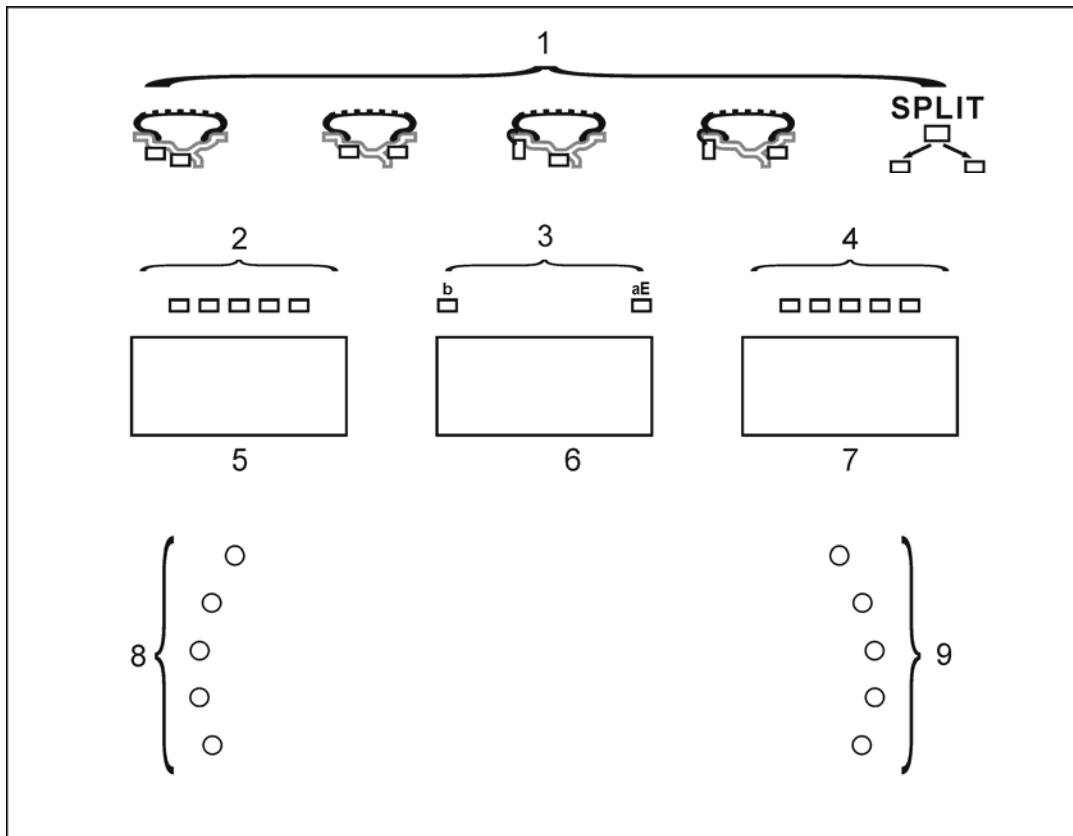

Figure 5-1

5.2 LED signification

Inside balance weight stick position indicator light:

ALU-S mode indicate inside stick balance weight position

Outside balance weight stick position indicator light:

ALU-S mode indicate out side stick balance weight position

Balance mode indicator light:

Indicate currently balance mode

Inside balance weight position indicator light:

Indicate inside balance weight position when all indicator light both on

Outside balance weight position indicator light:

Indicate outside balance weight position when all indicator light both on

5.3 Function key signification

Figure 5-2 key board

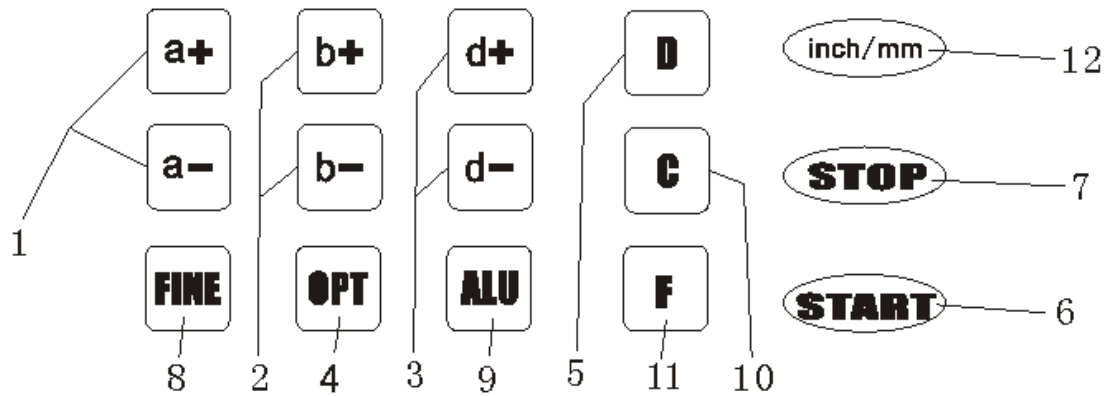

Figure 5-2

- 1- Push buttons, manual DISTANCE (a) setting
- 2- Push buttons, manual WIDTH (b) setting
- 3- Push buttons, manual DIAMETER (d) setting
- 4- Push button, optimization of imbalance and split imbalance
- 5- Push button, self-diagnostics, self-calibration and split imbalance
- 6- Push button, cycle start
- 7- Push button, emergency and selection of special functions
- 8- Push button, imbalance display pitch and threshold
- 9- Push button, selection of "ALU" mode of correction
- 10- Push buttons for recalculation and self-calibration
- 11- Selection, "STATIC" or "DYNAMIC" correction
- 12- Selection of dimensions, inch/mm

N.B. Only use the fingers to press push buttons. Never use the counterweight pincers or other pointed objects.

6. Installation and Demounting of the Wheel

6.1 Checking the wheel

The wheel must be clean, none sand or dust on it, and remove all the primal counterweights of the wheel. Check the tyre pressure whether up to the rated value. Check positioning plane of rim and mounting holes whether deformed.

6.2 Installing the wheel

6.2.1 Select the optimal cone for the center hole when there is center hole on the rim.

6.2.2 Two ways of installing the wheel: A. positive positioning; B. negative positioning.

6.2.2.1 Positive positioning (refer to figure 6-1):

Positive positioning is commonly used. It operates easily, and it is applicable for various rims of common steel structure and thin duralumin structure.

6.2.2.2 Negative positioning (refer to figure 6-2):

Negative positioning is used to ensure the inner hole of steel rim and main shaft is positioning accurately when the outside of wheel deforming. Apply for all the steel rims, thick steel rims especially.

6.2.3 Install wheel and cone on main shaft. Ensure the cone can clamp the wheel before screwing handle. Wheel can rotate after screwing down.

6.3 Demounting the Wheel

6.3.1 Demount the handle and cone.

6.3.2 Put the wheel up, and then take it down from main shaft.

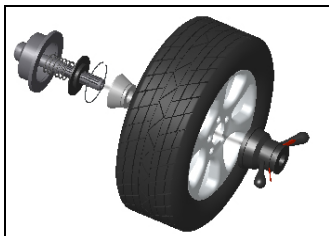

Figure 6-1

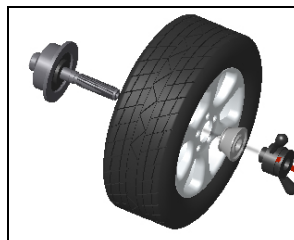

Figure 6-2

Note: do not slip wheel on main shaft to prevent main shaft from scuffing while installation and demounting the Wheel

7. The input methods of date of rim

7.1 The power-on state of the machine

After the power-on of the machine, it starts initialization automatically. The initialization will be finished after two seconds. The machine enter natural dynamic (clamp counterweights on the correction plane of the both edged sides of rim) mode automatically, as in Figure 7-1, ready for input date of rim.

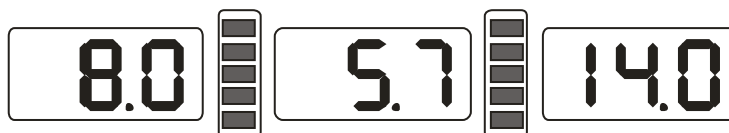

Figure 7-1

7.2 Date input method for normally dynamic balance mode

7.2.1 After the power-on of the machine, it enter the normal balance mode

7.2.2 Input date of rim:

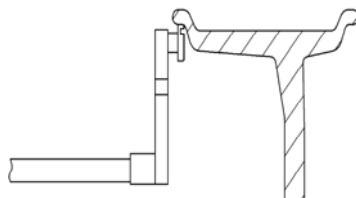

Figure 7-2

Rotate the measure scale, pull the scale head to inside concave on the edge of the rim, etc figure 7-2, first LED all off, then display ect figure 7-3,waiting put back scale.

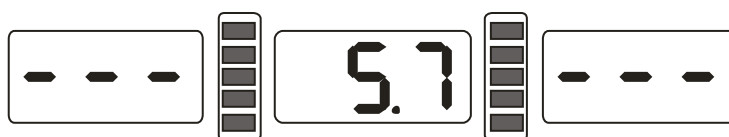

Figure 7-3

When scale back to zero position, LED display value is date of rim.

7.2.3 When measure values with fact value of rim differ, you need self-calibration of scales then measure again or manual input date of rim.

7.2.4 Input date of rim width

7.2.4.1 Put width scale head on rim outside edge, ect figure 7-4. First LED all off, then display ect figure 7-5, waiting put back scale.



Figure 7-4

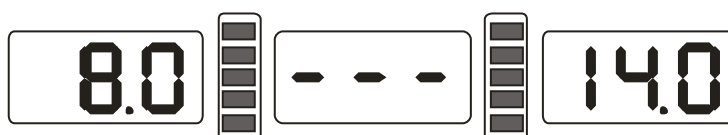

Figure 7-5

When width scale back to zero position, LED will be display ect figure 7-1.

7.2.4.2 When measure values with fact value of rim differ, you need self-calibration of width scale then measure again or manual input date of rim.

7.3 The date input method of ALU-S mode:

Normally from normal mode change to other mode, do not need input rim date again, just press ALU key change to you select mode in directly is fine, only ALU-S mode have special input method, ALU-S mean is special mode, include below two kind modes (Figure 7-6):



Figure 7-6

ect figure 7-7 or 7-8, Rotate the measure scale, pull the scale head to inside of the rim(FI)(this position is your select to stick balance weight on the inside), measure distance(a) and diameter (dI) of inside of the rim etc figure 7-9, then continue rotate measure scale, pull the scale head to outside of rim(FE) (this position is your select to stick balance weight on the outside), measure distance(aE) and diameter (dE) of outside of the rim etc figure 7-10, enter ALU-S mode.

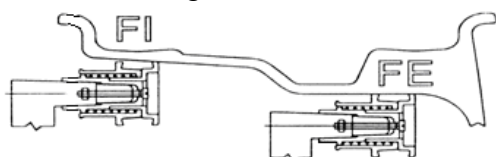

Figure 7-7

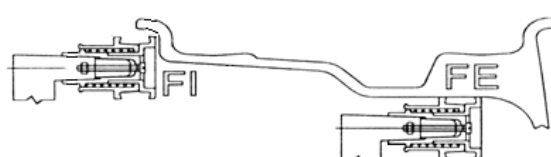

Figure 7-8

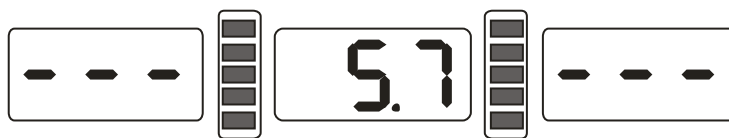

Figure 7-9



Figure 7-10

When scale back to zero position, LED will be display and aE and dI value. Press a+, a- can be adjust a value; press b+, b- can be adjust aE value; press d+, d- can be adjust dI value; press FINE key LED will display dE value, hold press FINE key and press d+, d- adjust dE value.

8. Calibration of measure scale

The measure scale was labeled before ex-factory, but the labeled value may vary because of transportation. Therefore, users can label it themselves before using the balancer.

After the power-on, the initialization is finished. Thus, users can label the measure scale

8.1 Calibration of rim distance scale

8.1.1 Press and hold STOP key and press FINE key, ect figure 8-1, press STOP key or C key to exit.



Figure 8-1

8.1.2 Move scale to 0(zero) position, press ALU key, ect figure 8-2, press STOP key or C key to exit.



Figure 8-2

8.1.3 Move scale to 15, press ALU key, ect figure 8-3, end of self-calibration, put back measure scale.



Figure 8-3

8.2 Calibration of diameter scale

8.2.1 install middle size tyre on principal axis, press and hold STOP key, and press OPT key, ect figure 8-4, press STOP key to exit;



Figure 8-4

8.2.2 Press d+ or d- adjust value to current rim diameter value, press ALU key, ect figure 8-5;



Figure 8-5

8.2.3 Move scale, put scale head on the inside edge of rim ect figure 7-2, press ALU key, ect figure 8-3, self-calibration end, put back scale.

8.3 Calibration of width scale

8.3.1 Press and hold STOP key and press b+ or b-, ect figure 8-6, press STOP key to exit;



Figure 8-6

8.3.2 Press ALU key, ect figure 8-7, press STOP key to exit;



Figure 8-7

8.3.3 Swing width scale, put scale head on the flange plane of principal axis ect figure 8-8, press ALU key ect figure 8-3, calibration end, put back width scale.

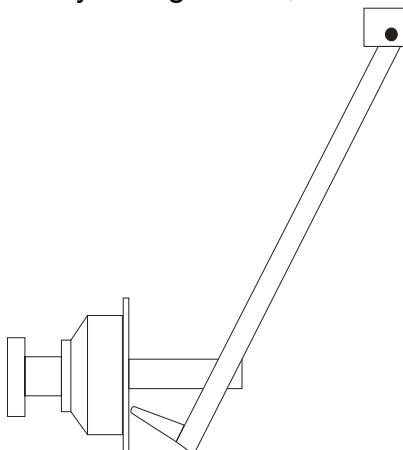

Figure 8-8

9. The Self-calibrating of Balancer

The self-calibrating of balancer was finished before ex-factory, but the system parameter may vary because of long-distance transportation or long-term use, which may cause error. Therefore, users can make self-calibrating after a period of time.

- 9.1 After the power-on of the machine, the initialization is finished ect figure 7-1, install a can clip counterweight and comparatively balance middle size tyre, follow step 7 input date of rim;
- 9.2 Press D key and C key, ect figure 9-1, (close protect hood), press START key, going to next step, press STOP key or C key to exit;



Figure 9-1

- 9.3 After axis stop, ect figure 9-2,(open protect hood)clip a 100 gram counterweight on anywhere of outside of rim, (close protect hood)press START key, going to next step, press STOP key or C key to exit;



Figure 9-2

- 9.4 After axis stop, ect figure 9-3, calibration end. Demount tyre, now balancer ready to work.



Figure 9-3

NB: when you doing self-calibration, input date of rim must be correct,100 gram counterweight must be correct, otherwise self-calibration result will be wrong, wrong self-calibration will be make balancer measure precision decline.

10. The Balancing Operation of Wheel

10.1 Balance mode change operation

10.1.1 Dynamic and static balance mode switch: press F key.

Dynamic balance mode: clip counterweight on inside and outside edge of rim (balancer tolerant normal balance mode), ect figure 10-1.

ST mode: static balance measure mode, stick counterweight on middle of rim, ect figure 10-2.

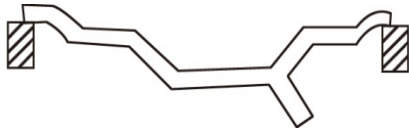
**Figure 10-1****Figure 10-2**

10.1.2 ALU balance mode switch key (ALU key), switch CPU system between ALU-S~ALU-3 mode.

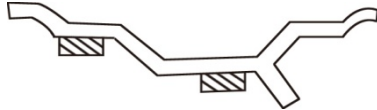
**Figure 10-3**

ALU-S mode: stick counterweight on inside two position of spoke of rim, ect figure 10-3.

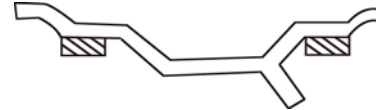
**Figure 10-4**

ALU-1 mode: stick counterweight on inside and outside of spoke of rim, ect figure 10-4.

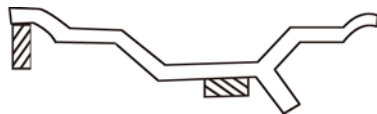
**Figure 10-5**

ALU-2 mode: clip counterweight on inside edge of rim, stick counterweight on outside (inside of spoke), etc figure 10-5.

**Figure 10-6**

ALU-3 mode: clip counterweight on inside edge of rim, stick counterweight on outside (outside of spoke), etc figure 10-6.

Counterweight split and Hidden-Stick Mode:

ALU-S mode, if the outside (inside of spoke) counterweight position between of two spokes, ALU-S mode can split the counterweight for two. The divided counterweight, just place on the back of two spokes near the former counterweight, in order to hide the counterweight ect figure 10-7.

**Figure 10-7**

10.2 Normal balance mode operation process

10.2.1 Follow figure 7.2 input date of rim.

10.2.2 Lay down protect hood and press START key, wheel spin, after stop two side LED display wheel both side imbalance weight, when middle LED display OPT, can choice imbalance optimize;

10.2.3 Slowly spin wheel, when inside counterweight position indicator light (figure 5-1(8)) all on, clip correspond counterweight on 12 o'clock position on inside of rim, ect figure 10-8;

- 10.2.4 Slowly spin wheel, when outside counterweight position indicator light (figure 5-1(8)) all on, clip correspond counterweight on 12 o'clock position on outside of rim, ect figure 10-9;

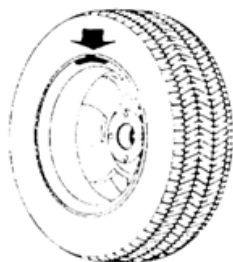

Figure 10-8

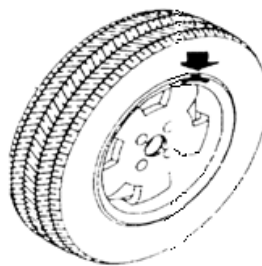

Figure 10-9

10.3 ALU-S balance mode operation process

★ Process of manual stickup counterweight

- 10.3.1 Follow figure 7.3 input date of rim.
- 10.3.2 Lay down protect hood and press START key, wheel spin, after stop two side LED display wheel both side imbalance weight, when middle LED display OPT, can choice imbalance optimize;
- 10.3.3 Slowly spin wheel, when inside counterweight position indicator light (figure 5-1(8)) all on, if is follow figure 7-8 input date of rim, next step follow 10.2.3 clip counterweight, if not, ect figure 10-10 of left side show, stick counterweight on 12 o'clock position on inside of rim.
- 10.3.4 Slowly spin wheel, when inside counterweight position indicator light (figure 5-1(9)) all on, stick correspond counterweight on 12 o'clock position on outside of rim, ect figure 10-10 right side;

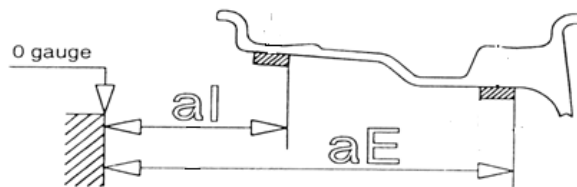

Figure 10-10

★ process of automatic stickup partition Counterweight

- 10.3.5 Follow figure 7.3 input date of rim
- 10.3.6 Lay down protect hood and press START key, wheel spin, after stop two side LED display wheel both side imbalance weight, when middle LED display OPT, can choice imbalance optimize;
- 10.3.7 If is follow figure 7-8 input date of rim, follow 10.2.3 clip counterweight on inside edge of rim. Press STOP key and ALU key, all middle of LED display - - -, follow 10.3.9 stick counterweight on outside of rim.
- 10.3.8 If is follow 7-7 input date of rim ,press STOP key and ALU key, all middle of LED display - - -,insert correspond counterweight into the scale head slot, slowly spin wheel, when inside counterweight position indicator light (figure 5-1(8)) all on, draught scale, when inside counterweight position indicator light (figure 5-1(2)) all on, turn scale, stick counterweight on the rim, ect figure 10-11;
- 10.3.9 Insert correspond counterweight into the scale head slot, slowly spin wheel, when outside counterweight position indicator light (figure 5-1(9)) all on, draught scale, when inside counterweight position indicator light (figure 5-1(4)) all on, turn scale, stick counterweight on the rim, ect figure 10-11;

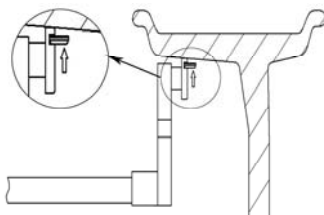

Figure 10-11

10.4 The operation process of M1 to M3 mode

- 10.4.1 Follow 7.2 input date of rim;
- 10.4.2 Press ALU key, switch to correspond balance mode.
- 10.4.3 Lay down protect hood and press START key, wheel spinning, after stop two side LED display wheel both side imbalance weight, when middle LED display OPT, can choice imbalance optimize;
- 10.4.4 Slowly spin wheel, when inside counterweight position indicator light (figure 5-1(8)) all on, follow different mode clip or stick counterweight on 12 o'clock position inside of rim.
- 10.4.5 Slowly spin wheel, when outside counterweight position indicator light (figure 5-1(9)) all on, follow different mode clip or stick counterweight on 12 o'clock position outside of rim.

10.5 Static balance (ST) operation process

- 10.5.1 Follow 7.2 input date of rim;
- 10.5.2 Press F key, switch to static balance (ST) mode.
- 10.5.3 Lay down protect hood and press START key, wheel spinning, after stop middle LED display wheel static imbalance weight, when middle LED display OPT, can choice imbalance optimize;
- 10.5.4 Slowly spin wheel, when both side counterweight position indicator light (figure 5-1(8), (9)) all on, stick counterweight on 12 o'clock position middle of rim. ect figure 10-12.



Figure 10-12

10.6 The of Counterweight Hide-Stick mode

Counterweight Hidden-Stick mode it can cut this position into two parts and make these two new positions hide behind the spoke, so you can achieve this hide purpose. This balance mode only available in ALU-S mode.

In 10.3 Operation process, if outside counterweight not hide behind the spoke, but you still want it hide behind the spoke, you can follow below operation:

10.6.1 Press a+ key, back to figure 7-1 interface, press D key and OPT key, display input numbers of spoke (figure 10-13), press b+ or b- key input spoke numbers, press D key and OPT key to save and return to balance interface, slowly turn the wheel, turn the near by imbalance position of spoke on the top (12 o'clock), press D and OPT key, two underneath lights of SPLIT mode lights will be on, indication already enter hide stick mode, and then press D and OPT key to exit;

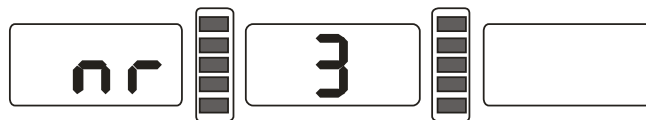

Figure 10-13

★ Split manual stick operation

10.6.2 Stick inside operation same 10.3.3;

10.6.3 Slowly spin wheel, when outside counterweight position indicator light (figure 5-1(9)) all on, stick counterweight on 12 o'clock position outside of rim, ect figure 10-10 right side;

10.6.4 Slowly spin wheel again, when outside counterweight position indicator light (figure 5-1(9)) all on, find second position, stick counterweight on 12 o'clock position outside of rim, ect figure 10-10 right side;

★ Split automatic stick operation

10.6.4 When stick inside, operation same 10.3.7 and 10.3.8

10.6.5 Slowly spin wheel, when outside counterweight position indicator light (figure 5-1(9)) all on, find first position, draught scale, when outside counterweight position indicator light (figure 5-1(4)) all on, turn scale, stick counterweight on rim (ect figure 10-11);

10.6.6 Slowly spin wheel, when outside counterweight position indicator light (figure 5-1(9)) all on, find second position, draught scale, when outside counterweight position indicator light (figure 5-1(4)) all on, turn scale, stick counterweight on rim (ect figure 10-11).

NB: when use scale automatic stick counterweight, make sure all LED must be display - - -, if not, do not move scale, press STOP and ALU key, then all LED display - - -, now you can move scale to stick up.

10.7 Recalculation

Before wheel balance testing, sometimes may forget input current date of rim, you can after wheel balance testing input date of rim reintroduce, at this time do not need press START key, just press recalculation key (C), system will follow new date of rim calculation imbalance measure. Even interface currently display imbalance value, press C key, can be check currently input date of rim.

11. Imbalance optimize

If wheel imbalance value over 30 gram, system will be display "OPT", clue on process imbalance optimize operation.

Imbalance optimize have two operation methods:

11.1 Already display balance value

If already finish balance testing, when you need process imbalance optimize, press OPT key, display ect figure 11-1;



Figure 11-1

Use chalk mark a reference point on the flange plane and rim and tyre, use tyre changer exchange rim and tyre 180°; Reinstall wheel on the balancer and make sure mark of reference point between the flange plane and rim must be on the same position. press START key, display effect figure 11-2;



Figure 11-2

Effect Figure 11-2, left LED display percent of optimize, if before optimize static value is 40 gram, optimized is 85%, so after optimize static value only 6 gram remain ($15\% \times 40\text{gram} = 6\text{gram}$);

Slowly spin wheel by hand, when both side two of position indicator light flashing (figure 11-3), use mark pen make a mark on the tyre;



Figure 11-3

Slowly spin wheel by hand again, when both side one of middle position indicator light flashing (figure 11-4), use mark pen make a mark on the rim;



Figure 11-4

Remove the wheel from balancer, use tyre changer remove tyre from rim, make tyre and rim marks together, use tyre changer fit tyre on the rim, optimize complete.

11.2 Before testing of process imbalance optimize directly

Turn on the power, installation wheel, press OPT key, left side display OPT, press START key, display effect figure 11-1, then follow 11.1 step to operation.

Press STOP key to stop operation.

12. Gram and Oz conversion operation

This operation for counterweight maund conversion (gram-Oz).

12.1 Press STOP key and a+ key or a-, display effect figure 12-1, denotation currently maund is gram.

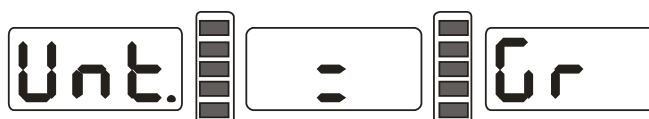

Figure 12-1

12.2 Press b+ or b- key, display effect figure 12-2, denotation currently maund is Oz,

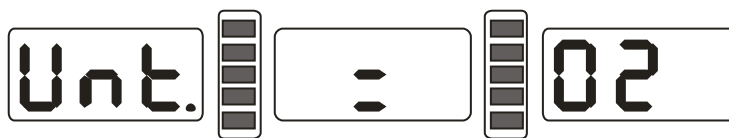

Figure 12-2

- 12.3 Press b+ or b- key for switch maund between gram and Oz;
- 12.4 Press a+ key to save setup and exit.

13. INCH and MM conversion operation

This operation for input dimension B value and D value conversion (INCH-MM). Press INCH/MM key, long measure of LED (figure 5-1(6)) display value B and LED (figure 5-1(7)) display value D can be change between INCH/MM. if in the LED display window right underside have a radix point mean currently long measure is INCH, if not, long measure is MM.

14. Protect hood function and settings

This function can be setting closing protect hood motor start or lay down protect hood properly, then press START key to start motor.

Press STOP key and C key, ect figure 14-1, right display currently state, when display ON, denotation function on, when display OFF, denotation function off.

- Press b+ or b- key for switch protect hood function between “ON” and “OFF”;
- Press a+ key to save currently settings and exit.

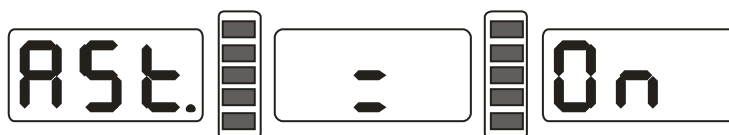

Figure 14-1

15. Other function settings

15.1 Minimum value display settings

After select minimum value display ,even wheel imbalance value less than setting value, result will be display 0(zero),press FINE key, will be display fact imbalance value. Press STOP and D key, ect figure 15-1,denotation imbalance value less than 5 gram, display is 0g(zero gram),press b+ or b- key setting minimum value, are 5 and 10 and 15gram three distinctions. Press a+ key to save settings and enter next step;



Figure 15-1

15.2 Key-tone clue on function settings

This function can turn on or turn off key-tone, even turn on this function, every time press key, system will be emit a “dl” of tone, even turn off this function, press key not tone.

From 15.1 press a+ enter settings, ect figure 15-2,right side display ON denotation function on, display OFF denotation function off. Press b+ or b- key, function will be switch between “ON” and “OFF”. Press a+ key to save settings and enter next step;



Figure 15-2

15.3 Display monitor brightness settings

This function will follow use environment and user need, setting display brightness. From 15.2 press a+ enter settings, ect figure 15-3,right side display brightness grade, altogether is 8 levels, level 1 is darkest, level 8 is brightest, default is level 4.press b+ or b- key, function will be switch brightness levels. Press a+ key to save settings and enter next step;



Figure 15-3

15.4 Width automatic measure settings

This function can turn on or turn off width automatic measure function, even width scale appear trouble can not operation like normal, switch off width automatic measure function.

From 15.3 press a+ enter settings, ect figure 15-4,right side display currently state, even display ON, denotation function turn on, even display OFF, denotation function turn off. Press b+ or b- key, function will be switch between “ON” or “OFF”.

If balancer not coming with width scale, can not turn width automatic measure function Press a+ key to save settings and exit.



Figure 15-4

16. Machine self test function

This function will be check all kinds input signal whether right working and provide gist for trouble analyses.

16.1 LED and indicator light check

Press D key, whole LED and indicator light all turn on, this function can be check LED or indicator light whether appear damage, press C key to exit, after about 5 seconds display ect figure 16-1,enter position sensor check. Press C key to exit.



Figure 16-1

16.2 Position sensor signal check

This function can be check position sensor and principal axis and main board circuit whether damage.

Slowly turn principal axis, right side LED display number appear change, clockwise turn, and value increase. Anticlockwise turn, value minish, correct value change is between 0 to 63. Press ALU key, enter distance sensor check. Press C key to exit.

16.3 Distance sensor signal check

This function can be check distance sensor and main board signal circuit whether damage.

From 16.2 press ALU key enter, ect figure 16-2, move measure scale, value will be change, value follow move more increase. Press ALU key, enter diameter sensor signal check. Press C key exit.



Figure 16-2

16.4 Diameter sensor signal check

This function can be check diameter sensor and main board signal circuit whether damage.

From 16.3 press ALU key enter, ect figure 16-3, turn measure scale, value will be change, anticlockwise turn, value increase, clockwise press turn, value minish. Press ALU key, enter width sensor signal check. Press C key exit.



Figure 16-3

16.5 Width sensor signal check

This function can be check width sensor and main board signal circuit whether damage.

From 16.4 press ALU key enter, ect figure 16-4, swing width measure scale, value

will be change, swing to left, value increase, and stay on origin value is least. Press ALU key, enter Pressure sensor signal check. Press C key exit.



Figure 16-4

16.6 Pressure sensor signal check

This function can be check Pressure sensor and main board signal circuit and power supply whether damage.

From 16.5 press ALU key enter, ect figure 16-5, gently press principal axis, right and left LED display value will be change, press ALU key, and enter pressure sensor signal check. Press C key exit.



Figure 16-5

17. Safety Protection and Trouble Shooting

17.1 Safety protection

17.1.1 Under the circumstance of operation, if the machine does not operate normally, press STOP key, the rotating wheel will stop immediately.

17.1.2 If hood is not laid down, press START key, the wheel will not rotate.

17.1.3 Under the circumstance of operation, if hood open, the rotating wheel will stop immediately.

17.2 Trouble shooting

17.2.1 After press START key, principal axis not rotates, LED displays Err-1.check motor, computer board and cable connections;

17.2.2 After press START key, principal axis rotate, LED display Err-1.check position sensor, computer board and cable connections;

17.2.3 If balance test already end, balancer still rotates for a long time, does not brake, check brake resistance, power supply board, computer board and cable connections;

17.2.4 If turn on the power LED display ect figure 17-1,need measure scale self-calibration or adjust a-value sensor or replacement new sensor;

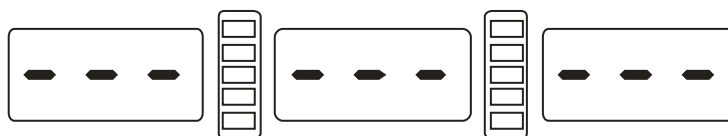

Figure 17-1

17.2.5 Automatic measure rim, advert display date whether difference with trim size of rim, if difference, need measure scale self-calibration;

17.2.6 If turn on the power LED display ect figure 17-2, need width measure scale self-calibration or change width sensor; also can follow 15.4 turn off width measure scale function, if balancer coming without width measure scale must be turn off this function; if after width measure and put width measure scale back LED display ect figure 17-2,press C key exit.

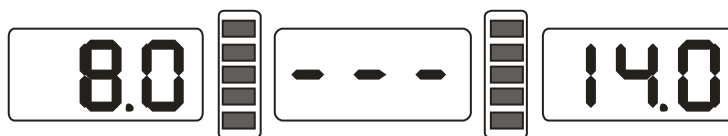

Figure 17-2

- 17.2.7 If turn on the power have not display, check power switch indicator light whether working, if not, check power supply first, then check power supply board and computer board and cable connections;
- 17.2.8 Precision not nicety, commonly hurtful not from balancer, may wheel installation wrong or counterweight heft not nicety or 100 gram counterweight for balance self-calibration not nicety, must be always keep manufactory's 100 gram counterweight safety for self-calibration only.
- 17.2.9 Date not astaticism, repeat difference, commonly hurtful not from balancer, may wheel installation wrong or floor not messiness not level off, may as well fixation balancer by bolt. Sometimes not connection earth wire may appear this phenomenon.
- 17.2.10 Width automatic measure not nicety, first check distance a-value input whether right, always input right a-value first then measure width b-value, if width automatic measure still not nicety, make width measure scale calibration.

Hint: check precision right method:

Input right date of wheel(a. b. d value),consult instruction do a self-calibration, press START process balance operation, note down date of first time, clip 100 gram counterweight on the outside edge of wheel(when outside indicator light all on is top zenith position),press START key again process balance operation, this date of outside display addition date of first time, should amount 100 ± 2 ,manually slowly turn the wheel, when light of outside all on, check 100 gram counterweight whether at 6 o'clock position, if not amount 100 gram or 100 gram counterweight not at 6 o'clock position, indicate balancer precision have problem, if amount is 100 gram, follow same method check inside, check inside whether amount is 100 gram and at 6 o'clock.

18. Maintenance

18.1 The daily maintenance of non- professionals

Before the maintenance, please switch off the power-supply.

18.1.1 Adjust the tension of the belt.

18.1.1.1 Dismantle the hood.

18.1.1.2 Unlash the screw of the motor, move the motor till the belt's tension is proper, and emphatically press the belt downwards about 4mm.

- 18.1.1.3 Tighten the screw of the motor and cover the hood.
- 18.1.2 Check whether the wire of electricity part connects reliably.
- 18.1.3 Check whether the pressed screw of the main axis is loose.
 - 18.1.3.1 Locking nut can not fix wheel tighten on main-axis
 - 18.1.3.2 Use hexagonal wrench to tighten the pressed screw of the main-axis.

18.2 The maintenance of professionals

The maintenance of professionals can only be carried out by the professionals from the factory.

18.2.1 If the imbalance value of tested wheel has obvious errors and does not improve after self-calibrating, this proves the parameter in the machine has altered, so the user should ask for professionals.

18.2.2 The replacing and adjustment of pressure sensor should be operated according to the following methods, and the operation should be carried out by professionals.

The steps are as follows:

1. Unlash the No.1, 2,3,4,5 nuts.
 2. Dismantle the sensor and nut.
 3. Replace No.6, 7 the sensor organ.
 4. Install the sensor and the nut according to the Figure 18-1. (Pay attention to the sensor's direction.)
 5. Tighten No.1 nut emphatically.
 6. Tighten the No.2 nut to make the main shaft and the flank of cabinet, and then emphatically tighten the No.3 nut.
 7. Tighten the No.4 nut (not too emphatically), then tighten No.5 nut.
- 18.2.3 The replacing of circuit board and the organ on it should be carried out by professionals.

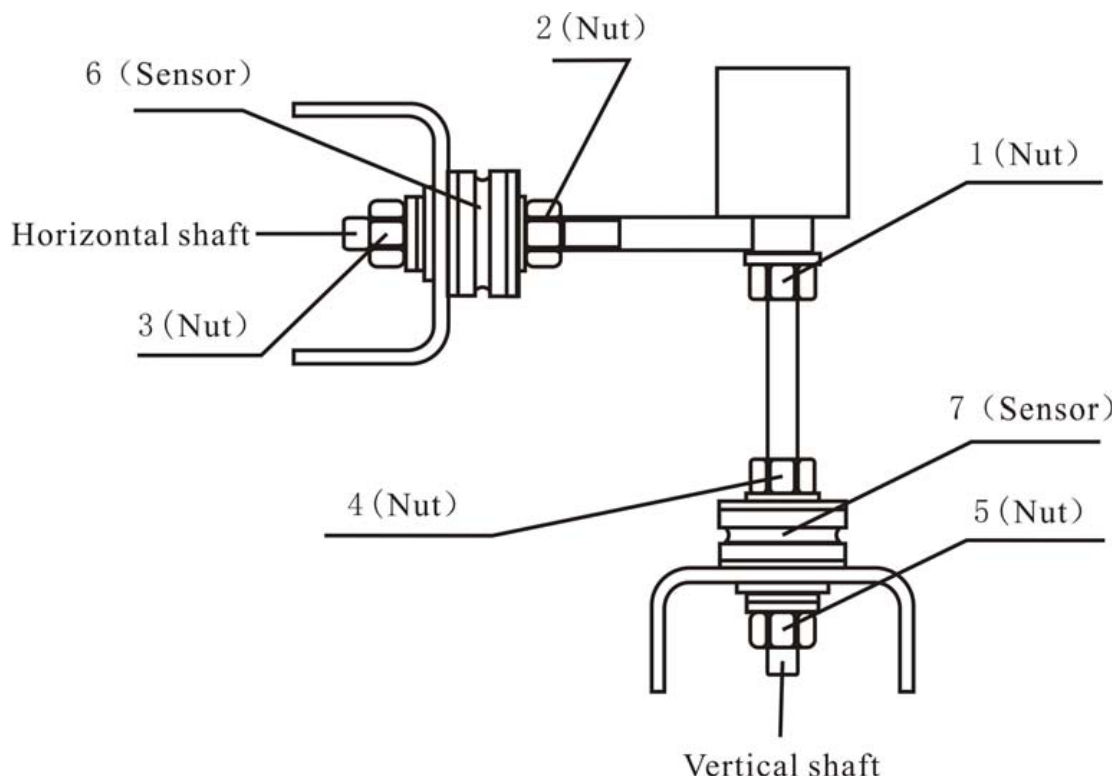

Figure 18-1

19. Trouble-error code list

When balancer display hint of error, can follow consult below list to remove the trouble:

Code	meanings	cause	remedy
Err 1	principal axis not spin or have not spin signal	1.motor fault 2.position sensor fault 3.power supply board fault 4.computer board fault 5.connection-peg untouched	1.change motor 2.change position sensor 3.change power supply board 4.change computer board 5.check cable connections
Err 2	The rotation is lower than 60r/min	1. position sensor fault 2. wheel not impacting or weight too light 3. motor fault 4. driving belt too loose or too tighten 5. computer board fault	1. change position sensor 2.repeat impacting wheel 3. change motor 4.adjust driving belt elasticity 5. change computer board
Err 3	Miscalculation	too high imbalance	Repeat the self-calibration change computer board
Err 4	principal axis Wrong rotation direction	1. position sensor fault 2. computer board fault	1. change position sensor 2. change computer board
Err 5	Protection hood not lay down	1.when press START key, Protection hood not lay down 2. jiggle switch fault 3. computer board fault	1.follow right method operation 2.change jiggle switch 3. change computer board
Err 6	Sensor signal transact circuit not working	1. power supply board fault 2. computer board fault	1. change power supply board 2. change computer board
Err 7	Lose date of interior	1. Incorrect self-calibration 2. computer board fault	1. Repeat the self-calibration 2. change computer board
Err 8	Self-calibration memory fault	1. not put 100 gram on the rim when self-calibration 2. power supply board fault 3. computer board fault 4. Pressure sensor fault 5. connection-peg untouched	1.follow right method repeat self-calibration 2. change power supply board 3. change computer board 4.change Pressure sensor 5.check cable connection

20. Power supply layout diagram

20.1 220 V Connection

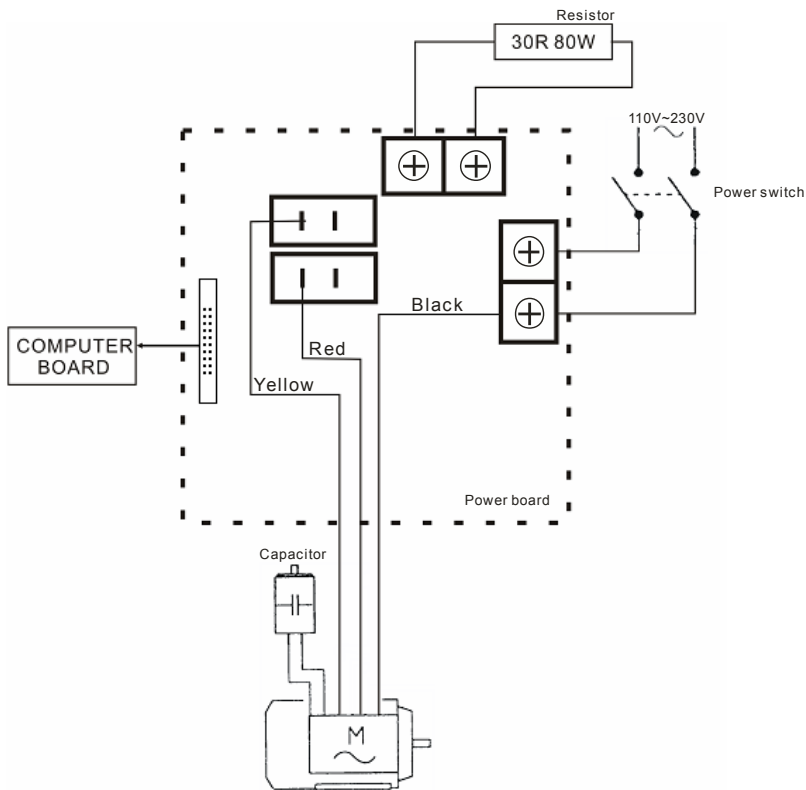

20.2 380 V Connection

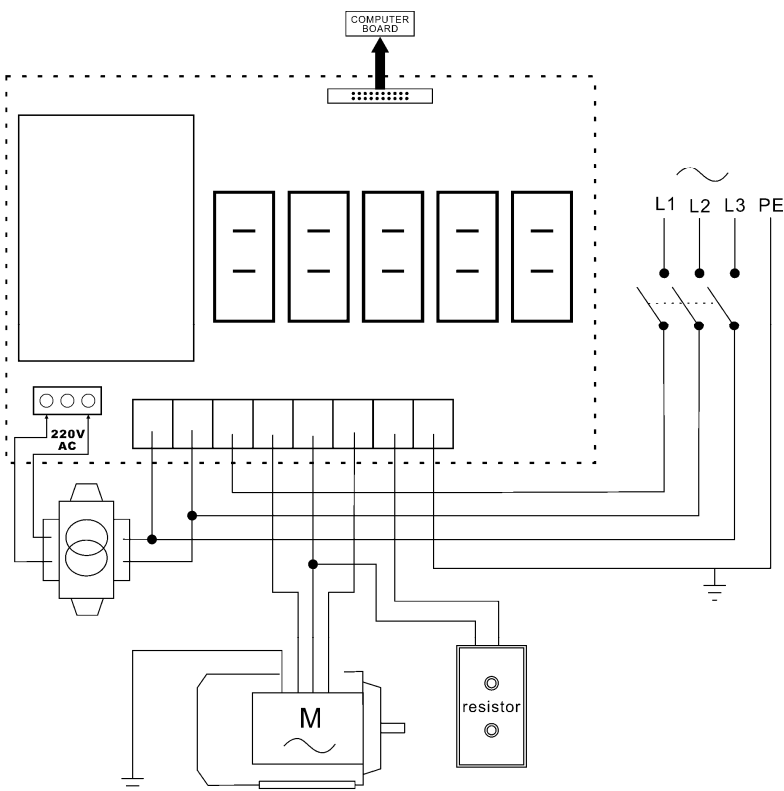

21. Exploded drawings

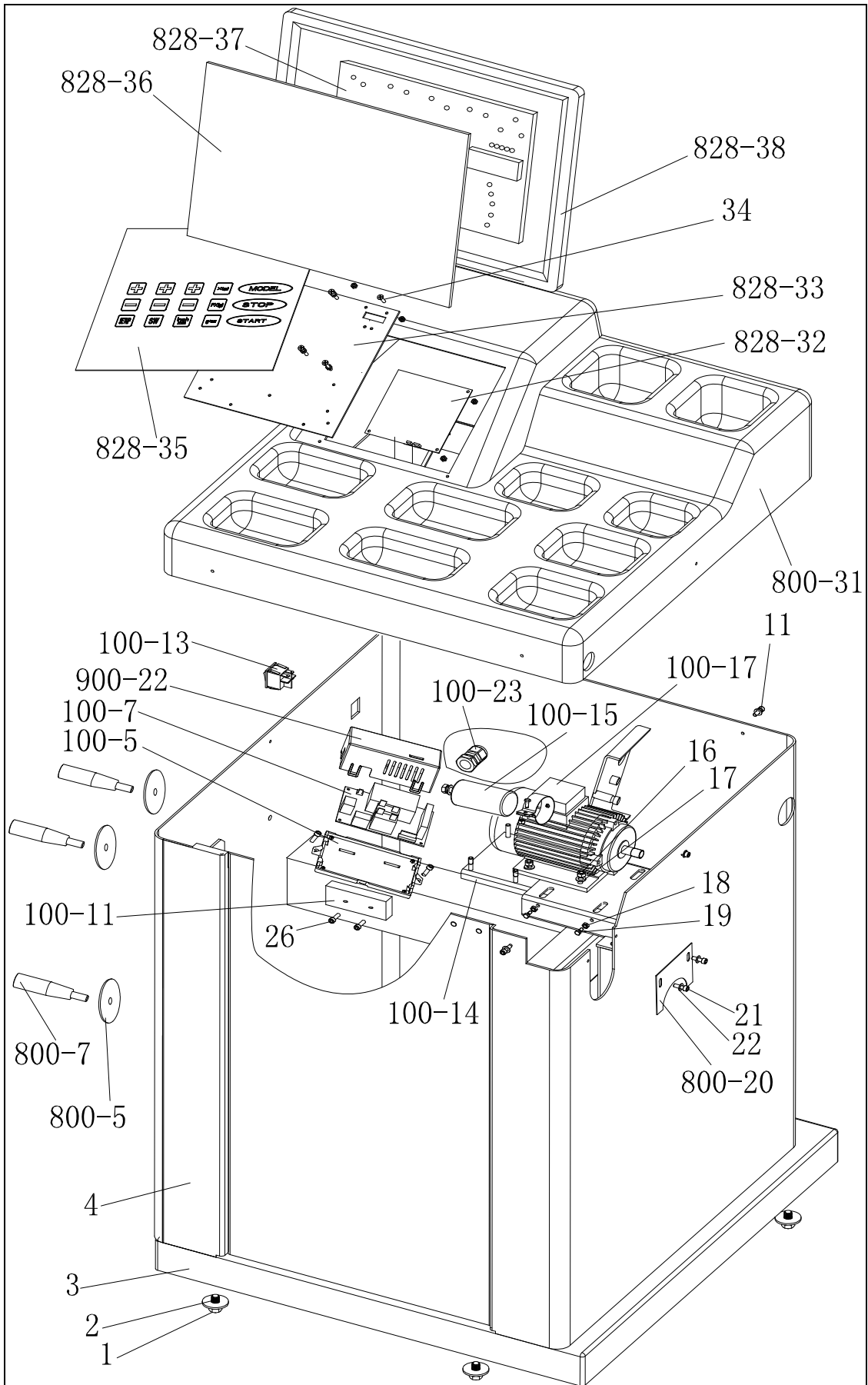

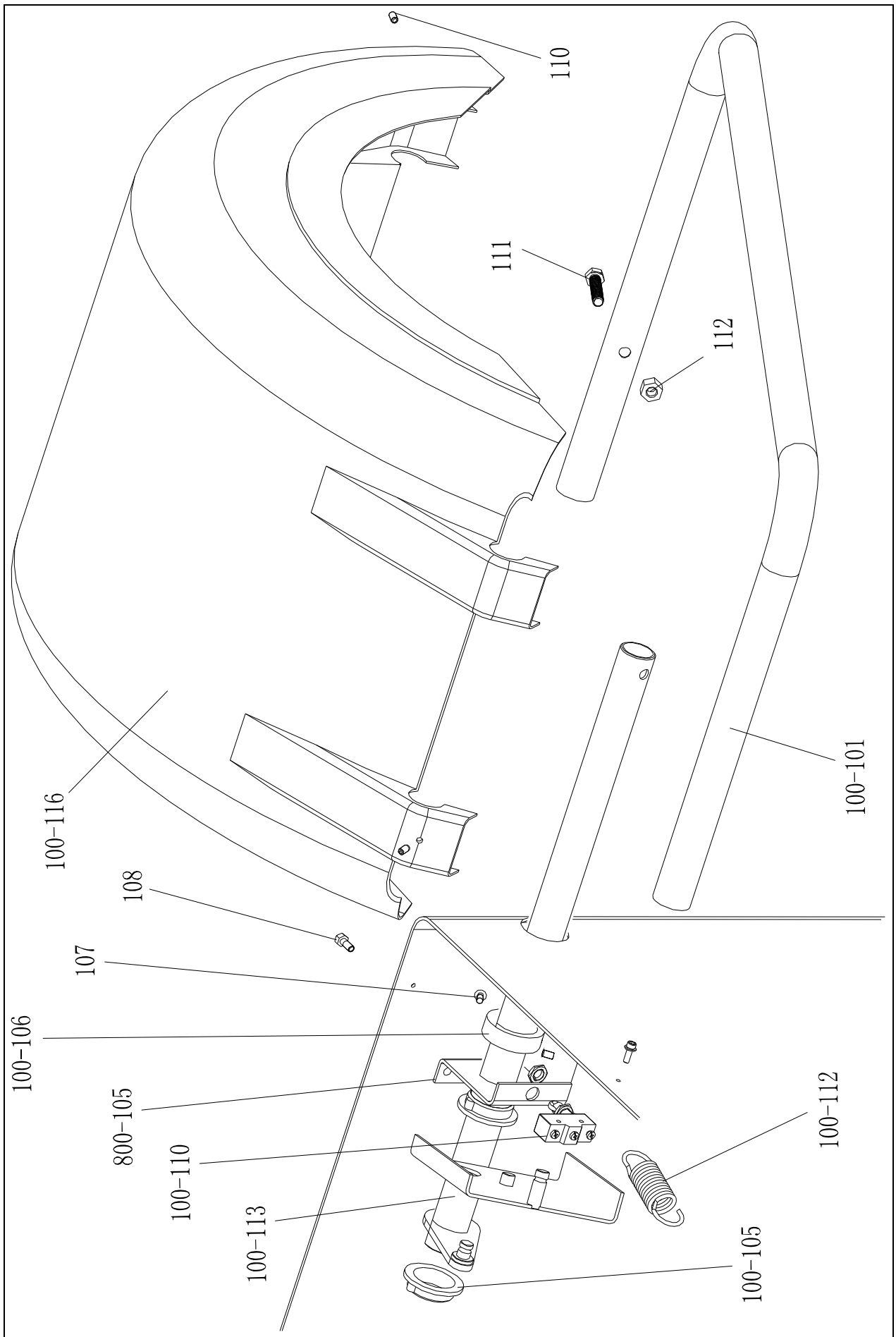

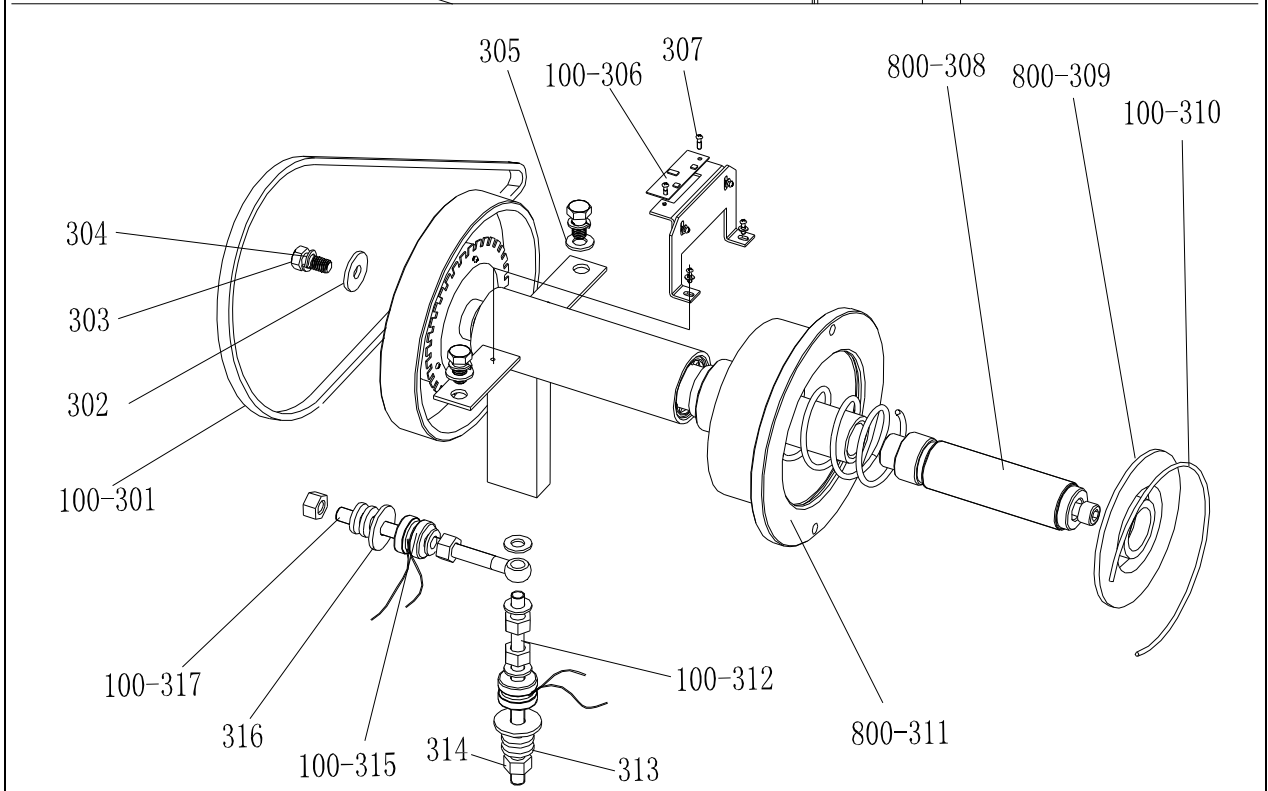
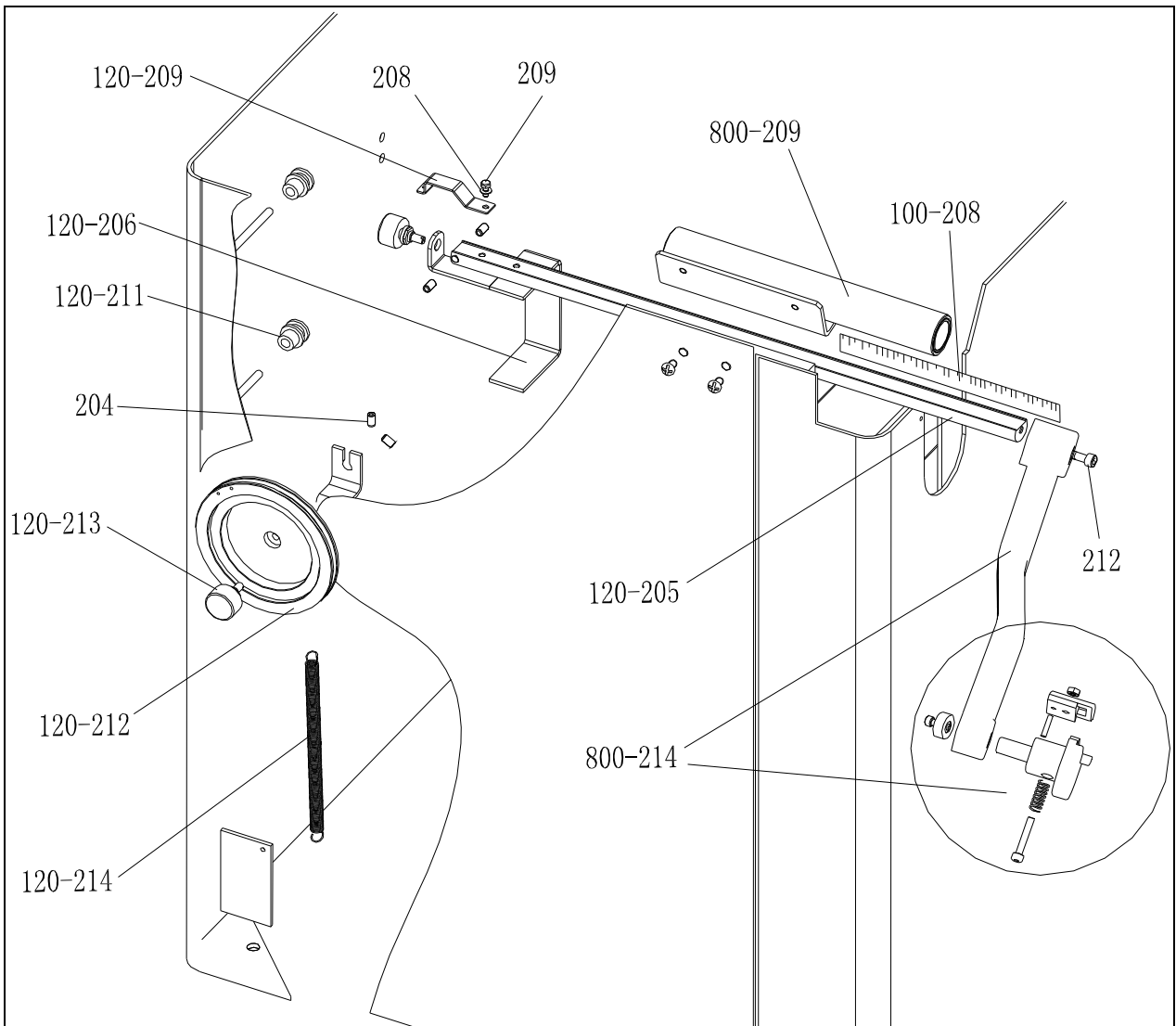

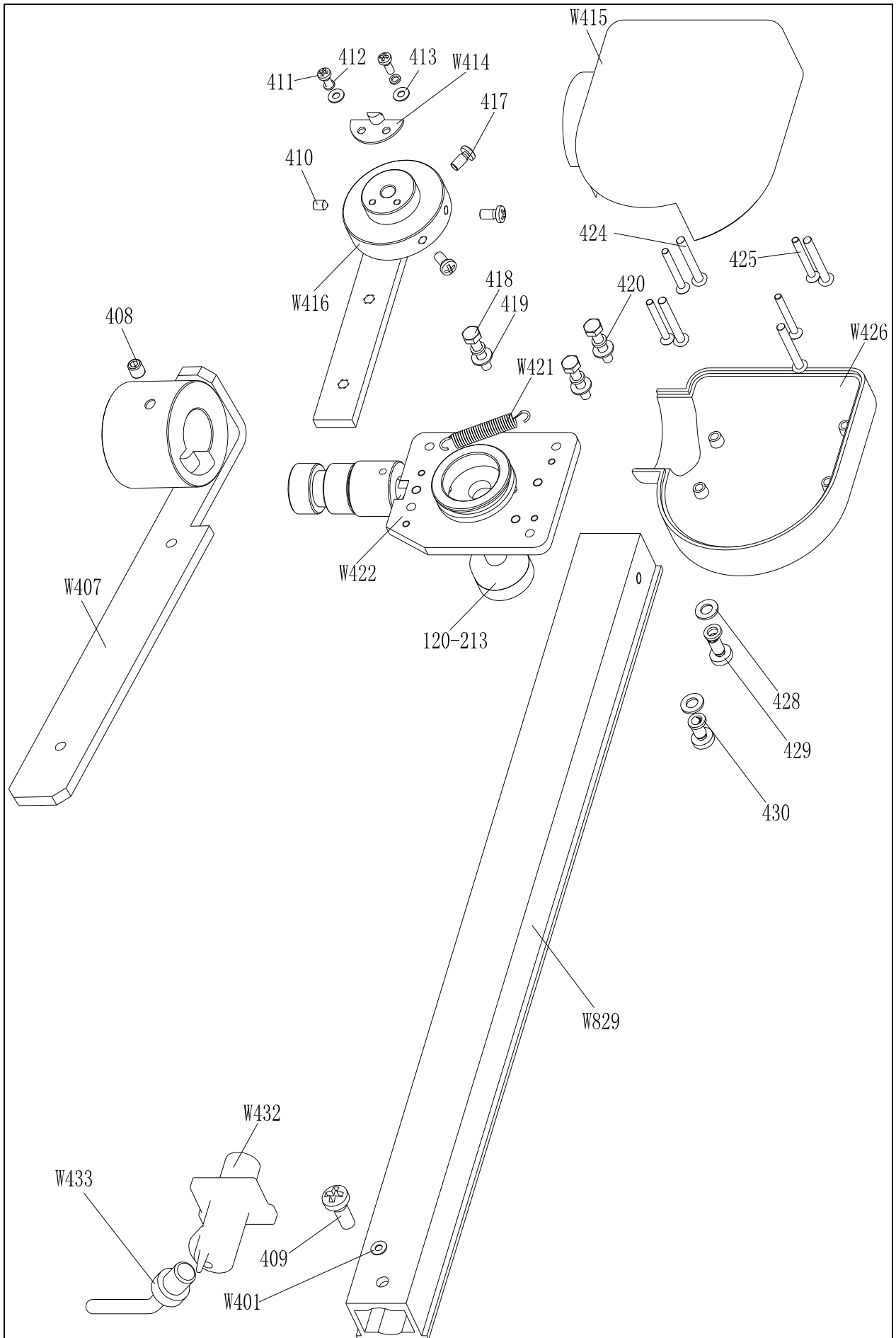

22. Spare parts list

No.	Code	Description	Qt	No.	Code	Description	Qt
1	B-014-100251-0	Screw	4	108	B-010-080201-1	Screw	2
2	B-040-103030-1	Washer	2	100-116	P-100-200100-0	Hood	1
3	PX-800-020000-0	Base	1	110	B-007-060081-0	Screw	3
4	PX-800-010000-0	Body	1	111	B-014-100451-0	Screw	1
800-5	P-000-009002-0	ABS Washer	3	112	B-001-100001-0	Nut	1
800-7	P-000-009000-0	Tools hang	3	100-101	PX-100-200200-0	Shaft	1
100-13	S-060-000210-0	Power switch	1				
100-23	S-025-000135-0	Cable circlip	1	120-214	P-120-210000-0	Spring	1
100-14	PX-100-010920-0	Motor adjust board	1	120-212	P-120-250000-0	Bobbin winder pulley	1
11	B-024-050161-1	Screw	4	120-213	S-132-000010-0	Gauge sensor	2
100-15	S-063-002000-0	Capacitor	1	204	B-007-060081-0	Screw	5
100-17	S-051-230020-0	Motor	1	120-211	PZ-120-260000-0	Pulley	2
16	B-004-060001-1	Nut	4	120-206	PX-120-240000-0	Heavy	1
17	B-040-061412-1	Washer	4	120-209	PX-120-230000-0	Caliper Hook	1
18	B-004-050001-1	Nut	2	208	B-040-050000-1	Washer	1
19	B-014-050351-1	Screw	2	209	B-024-050161-1	Screw	1
800-20	PX-100-110000-0	Plate	1	800-209	PX-820-570000-0	Gauge support	1
21	B-024-050061-0	Screw	2	212	B-010-060161-0	Screw	1
22	B-040-050000-1	Washer	2	120-205	PZ-120-090000-0	Rim Distance Gauge	1
100-7	PZ-000-020822-0	Power board		100-208	Y-004-000070-0	Graduated Strip	1
100-5	P-100-120000-0	Electric Board Support	1	800-214	PW-109-082800-0	Handle Bar	1
26	B-024-050251-0	Screw	1				
100-11	D-010-100300-1	Resistor	2	100-301	S-042-000380-0	Belt	1
800-31	P-800-190000-0	Head with tools-tray	1	302	B-040-103030-1	Washer	1
828-32	PZ-000-010829-0	Computer board	1	303	B-014-100251-0	Screw	3
828-33	PX-830-100000-0	Key plate	1	304	B-050-100000-0	Washer	3
34	B-017-030251-0	Screw	1	305	B-040-102020-1	Washer	6
828-35	S-115-008290-0	Key board	8	100-306	PZ-000-040100-0	Position Pick-up Board	1
828-36	S-135-101829-5	Display plate	1	307	B-024-030061-0	Screw	4
828-37	PZ-000-010829-5	Display board	1	800-308		Thread	1
828-38	S-135-101500-0	Display box	1	800-309	P-100-420000-0	Plastic Lid	1
			1	100-310	P-100-340000-0	Spring	1
100-112	P-100-210000-0	Spring		800-311	S-100-000800-0	Complete Shaft	1
100-105	P-800-180000-0	Sheath	1	100-312	P-100-080000-0	Screw	1
100-113	PX-800-040000-0	Shaft	2	313	B-048-102330-1	Washer	4
100-110	S-060-000400-0	Micro switch	1	314	B-004-100001-2	Nut	5
800-105	PX-100-200200-0	Shaft support	1	100-315	S-131-000010-0	Sensor Assembly	2
100-106	PX-800-050000-0	Shaft sheath	1	316	B-040-124030-1	Washer	2
107	B-024-060061-0	Screw	1	100-317	P-100-070000-0	Screw	1

No.	Code	Description	Qt.	No.	Code	Description	Qt.
W401	P-870-011800-0	Magnet	1	420	B-050-040000-0	Spring washer	3
W407	P-870-011001-0	Installation board assembly	1	421	P-870-010900-0	spring	1
408	B-007-060081-0	Screw	1	W422	P-870-010100-0	Revolve shaft assembly	1
409	B-019-420161-0	Screw	1	120-213	S-132-000010-0	Gauge sensor	1
410	B-007-040061-0	Screw	2	424	B-024-350281-0	Screw	4
411	B-024-030081-0	Screw	2	425	B-017-030251-0	Screw	4
412	B-050-030000-0	Spring washer	2	W426	P-870-010700-0	Bottom cover	1
413	B-040-030000-1	Flat washer	1	428	B-040-050000-1	Flat washer	2
W414	P-870-010600-0	Fix the slice	1	429	B-024-050101-0	Screw	2
W415	P-870-010400-0	Top cover	1	430	B-050-050000-0	Spring washer	2
W416	P-870-010500-0	Connection of arm assembly	1	W829	P-870-010800-0	Ruler seat	1
417	B-024-040081-0	Screw	3	W432	P-870-011500-0	Ruler head support	1
418	B-010-040201-0	Screw	3	W433	P-870-011400-0	Ruler head	1
419	B-040-040000-1	Flat washer	3				

S Version Exploded drawings and spare parts list (Optional pedal brake system)

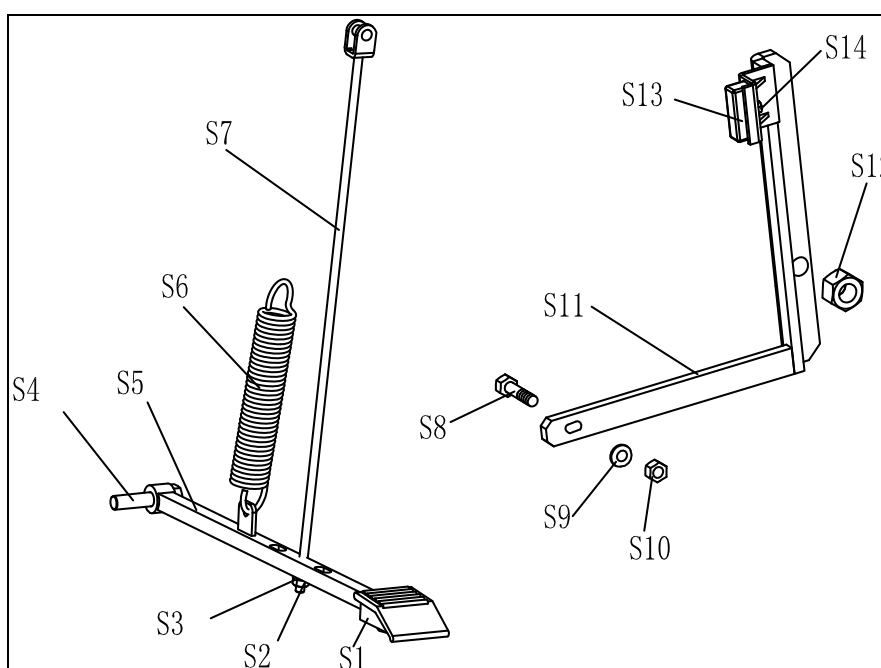

No.	Code	Description	Qt.	No.	Code	Description	Qt.
S1	C-221-640000-A	Rubber cover	1	S8	B-010-060301-0	Screw	1
S2	B-001-060001-0	Nut	1	S9	B-040-061412-1	Washer	1
S3	B-040-061412-1	Washer	1	S10	B-004-060001-1	Nut	1
S4	B-014-100251-0	Screw	1	S11	PX-100-020200-0	Brake lever	1
S5	PX-800-020300-0	Foot lever	1	S12	B-001-120001-0	Nut	1
S6	C-200-380000-0	Spring	1	S13	P-000-002001-1	Brake pads	4
S7	PX-100-020400-0	Connecting rod	1	S14	B-004-060001-1	Nut	2

Accessories list

Specification options 1: 36 2: 40

CODE	ITEM	QTY	PHOTO	
1:S-100-036000-1	1# CONE	1		1: ϕ 36
2:S-100-040000-1				2: ϕ 40
1:S-100-036000-2	2# CONE	1		1: ϕ 36
2:S-100-040000-2				2: ϕ 40
1:S-100-036000-3	3# CONE	1		1: ϕ 36
2:S-100-040000-3				2: ϕ 40
1:S-100-036000-4	4# CONE	1		1: ϕ 36
2:S-100-040000-4				2: ϕ 40
1:P-005-100000-0	COMPLETE QUICK RELEASE NUT	1		1: ϕ 36
2:P-005-100040-0				2: ϕ 40
1:P-100-400000-0	THREADED SHAFT	1		1: Tr36
2:P-828-400000-0				2: Tr40
Y-032-020829-0	MANUAL	1		
PX-100-200400-0	WRENCH	1		
S-105-000080-0	HEX WRENCH	1		
S-105-000060-0	HEX WRENCH	1		
S-110-001000-0	STANDARD WEIGHTS 100G	1		
P-000-001-008-0	CALIPER	1		
S-108-000010-0	PLIER	1		
P-100-490000-0	PLASTIC LID	1		
P-000-001002-0	RUBBER BUFFER	1		

For one item with two codes, please select as per Specification Options, or select by measuring real object.

Attach figure 1 System circuit diagram

