

Operation Manual for Screw-Type Air Compressor



Before installation and initial operation of the air compressor, please read the manual carefully and clearly learn about relevant information guideline for operation and maintenance about the compressor.

Please hand over the manual and the machine together to the user.

There are important safety information in the technical manual, please save it together with the compressor.

Contents

1. Introduction to Products and Descriptions.....	2
2. Operating principle	4
3. Main Technical Data.....	5
4. Main Structure.....	8
5. Pipeline Flow Diagram	9
6. Electrical Principle Diagram	11
7. Warnings and Announcements	13
8. Equipment Installation.....	16
9. Equipment Operation	17
10 Operation and Maintenance	18
11. Breakdown and Elimination	24
12. Directly Connected-Type Screw Compressor	26
13. Conveyor-Type Screw Compressor	28

1. Introduction to Products and Descriptions

Thank you very much for choosing and using XL series screw air compressor manufactured by the company. Please read the user's manual carefully before operating the machine.

XL series screw compressor is a two-shaft positive displacement rotating type air compressor; with an alternate name of two-shaft air compressor. The compressor has high and reliable operation characteristics, high gas transmission efficiency characteristics, excellent dynamic balance characteristics, low noise and vibration as well as easy operation and maintenance. It is of long performance life and environment protection. Commonly used in industries of precision machinery and instruments, electronic products and food, Chemical Fiber and Textile, aerospace application and chemistry, decorative coating, medical pharmaceutical, traffic transportation and agriculture etc., Products have a universally acknowledged development prospects.

1.1 Description on the compressor

The screw compressor manufactured by the company is an achievement of several years' research and development. The combination of these prerequisite conditions guarantees a long performance life, high reliability and operational efficiency. The products meet all requirements for environment protection.

1.2 Range of application

The machines and units of the series are manufactured according to mature technology and recognized safety rules. The occurrence of the following, however, might cause threat to the user or life and body of the third party, which might cause damage to the machines and other material possessions

- Incorrect range of application
- Operation by unqualified personnel
- Unreasonable modification or transform to the machines
- Nonobservance to safety rules

As a result, all staff that has the right to operate, maintain or repair the machines has to read and obey all safety rules. It can be confirmed by signature if necessary.

Besides, the following shall also be obeyed:

- Relevant accident prevention rules
- Acknowledged safety rules
- National laws and regulations.

The machines and units of the series must be operated in perfect technical conditions and must be operated compliance with the range of application and guideline specified in the operation manual. The operators shall have strong safety awareness and fully recognize the risks during the operation of the machines. Any functional breakdowns, especially those that will threaten the safety, must be repaired in time (Or ask others to repair it)!

The meaning of operating the machines in range of application also includes observing the guideline in the operation manual , check and maintaining as required.

1.3 Maintenance

The machines must be carefully maintained to meet various requirements for screw compressors or compressor units. The machines, therefore, must be carefully maintained during the specified maintenance period, especially in condition of bad working environment.

If there is any breakdown or requirements for spare parts, please contact with compressor manufacturer of my company. If there is any damage to the equipment, the well-trained serviceman of my company will provide excellent after-sales service with the parts manufactured by my company. The authentic parts manufactured by my company are of mature technology and therefore are able to guarantee reliable operation of the machine.

Guarantee

Get wise to the machine as well as relevant introductions before operating the machine. If the operation of the machine is inconsistent with the range of application or intended use goes beyond the range mentioned in the manual, the company will not be responsible for safety of the operation.

In following conditions, warranty claim will not be accepted by my company:

- Maloperation
- Improper maintenance
- Misuse of auxiliary materials
- Nonuse of the original parts manufactured by my company
- Modifying or repairing the equipment
-

The company refuses to expand the warranty or compensation conditions.

Any arbitrary modifications to the compressor or compressor station or installation of parts which are not authorized by the manufacturer are not accepted by the manufacturer for warranty or compensation conditions.

Safety rules

Safety rules in the operation guideline shall be strictly abided by.

Technical modification

We reserve the right to modify the parts without prior notification during the process of technical research and development.

Note: If you have any demand, please contact with the local service provider of my company at any time, we will provide more excellent service for you.

2 Operating Principle

A complete operating cycle of screw air compressor includes three procedures, inspiration, compression and exhaust. Each pair of gears which are meshing to each other will complete the same operating cycle in succession when the rotor is rotating. To make thing simple and clear, we research the whole operating process of a pair of gears.

a) Procedure of inspiration: As the rotor begins to rotate, one end of the gear gradually demeshes to form a cavity between gears. With expansion of the cavity, there forms some vacuum inside. As the cavity between gears are only connected to air entry, therefore air flows inside under the effect of differential pressure. During the subsequent process of rotor rotation, the male rotor gear ceaselessly demeshes from the gear slot of the female rotor, with on increase in cavity between gears. The cavity breaks from the air entry and the sealed up between the gears. The procedure of inspirations is completed.

b) Procedure of compression: As the rotor is rotating, cavity between gears continuously reduces as rotating gear meshes. Reduction in volume of the air in the sealed cavity between gears causes pressure rise. Thereby the procedure of air compression is carried out.

c) Procedure of exhaust: As the cavity between gears continuously reduces, the air with exhausting pressure is ceaselessly conveyed to exhaust orifice and exhausted out. This process continues till the complete mesh of shaped wires in the end. For the time being, the compressed air in cavity between gears is conveyed to exhaust orifice and completely exhausted out. The volume of sealed cavity between gears becomes zero and the procedure of air compression is carried out.

Table 1

3 Main Technical Data

Type		XL10A	XL15A	XL20A	XL25A	XL30A	XL40A	XL50A	XL60A	XL75A	XL100A
Motor power	KW	7.5	11	15	18.5	22	30	37	45	55	75
Air displacement/exhaust pressure	(m ³ /min) /Mpa	1.2/0.7	1.65/0.7	2.25/0.7	3.22/0.7	3.6/0.7	5.2/0.7	6.58/0.7	7.36/0.7	10.8/0.7	13.5/0.7
		1.1/0.8	1.53/0.8	2.03/0.8	3.01/0.8	3.56/0.8	5.06/0.8	6.26/0.8	7.1/0.8	10.1/0.8	12.7/0.8
		0.95/1	1.32/1	1.82/1	2.52/1	3.07/1	4.53/1	5.8/1	6.47/1	8.5/1	11.3/1
		0.8/1.2	1.1/1.2	1.55/1.2	2.3/1.2	2.84/1.2	3.9/1.2	5.06/1.2	5.8/1.2	7.69/1.2	10/1.2
Cooling mode		Air cooled	Air cooled	Air cooled	Air cooled	Air cooled	Air cooled	Air cooled	Air cooled	Air cooled	Air cooled
Drive mode		Conveyor	Conveyor	Conveyor	Conveyor	Conveyor	Conveyor	Conveyor	Conveyor	Conveyor	Conveyor
Starting mode		Directly connected	Y-Δ	Y-Δ	Y-Δ	Y-Δ	Y-Δ	Y-Δ	Y-Δ	Y-Δ	Y-Δ
Length×Width×Height (mm)	L	940	1180	1180	1280	1280	1350	1500	1500	1900	1900
	W	540	720	720	760	760	880	970	970	1200	1200
	H	850	1090	1090	1200	1200	1220	1350	1350	1580	1580
Net weight	Kg	2250	450	465	565	615	700	880	950	1565	1600
Noise	d B(A)	62±2	63±2	63±2	63±2	65±2	65±2	65±2	68±2	68±2	72±2
Diameter of outlet pipe		G3/4"	G3/4"	G3/4"	G1 1/4"	G1 1/4"	G1 1/4"	G1 1/2"	G1 1/2"	G1 1/2"	G2"

Table 1 -Continue

Type		XLD30A	XLD50A	XLD75A	XLD100A	XLD120A	XLD150A	XLD175A	XLD200A	XLD250A	XLD300A	XLD350A
Motor power	KW	22	37	55	75	90	110	132	160	185	220	250
Air displacement/exhaust pressure	(m ³ /min) /Mpa	3.6/0.7	6.58/0.7	10.8/0.7	13.5/0.7	16.2/0.7	21.6/0.7	25.2/0.7	28.7/0.7	32.5/0.7	36.8/0.7	42.7/0.7
		3.56/0.8	6.26/0.8	10.1/0.8	12.7/0.8	15.2/0.8	20.1/0.8	24/0.8	27.6/0.8	30.8/0.8	34.7/0.8	40.8/0.8
		3.07/1	5.8/1	8.5/1	11.3/1	14.3/1	17.5/1	21/1	25.3/1	28.2/1	30.8/1	38.1/1
		2.84/1.2	5.06/1.2	7.69/1.2	10/1.2	12.9/1.2	16/1.2	18.3/1.2	22.4/1.2	25.1/1.2	28.9/1.2	34.9/1.2
Cooling mode		Air cooled	Air cooled	Air cooled	Air cooled	Air cooled	Air cooled	Air cooled	Air cooled	Air cooled	Air cooled	Air cooled
Drive mode		Directly connected	Directly connected	Directly connected	Directly connected	Directly connected	Directly connected	Directly connected	Directly connected	Directly connected	Directly connected	Directly connected
Starting mode		Y-Δ	Y-Δ	Y-Δ	Y-Δ	Y-Δ	Y-Δ	Y-Δ	Y-Δ	Y-Δ	Y-Δ	Y-Δ
Length×Width×Height (mm)	L	1280	1500	1900	1900	2000	2200	2200	2400	2400	3100	3100
	W	760	970	1200	1200	1200	1550	1550	1650	1650	2150	2150
	H	1190	1350	1580	1580	1500	2000	2000	1900	1900	2320	2320
Net weight	Kg	595	880	1450	1650	1870	2500	2650	3200	3500	3900	4950
Noise	dB(A)	63±2	63±2	65±2	68±2	68±2	68±2	72±2	72±2	72±2	76±2	76±2
Diameter of outlet pipe		G1 ¹ / ₄ "	G1 ¹ / ₂ "	G2"	G2"	G2"	DN65	DN65	DN80	DN80	DN80	DN80

Table 1 -Continue

Type		XLV25A	XLV30A	XLV40A	XLV50A	XLV60A	XLV75A	XLV100A	XLVD75A	XLVD100A	XLVD120A	XLVD150A	XLVD175A
Motor power	KW	18.5	22	30	37	45	55	75	55	75	90	110	132
Air displacement/exhaust pressure	(m ³ /min) /Mpa	3.22/0.7	3.6/0.7	5.2/0.7	6.58/0.7	7.36/0.7	10.8/0.7	13.5/0.7	10.8/0.7	13.5/0.7	16.2/0.7	21.6/0.7	25.2/0.7
		3.01/0.8	3.56/0.8	5.06/0.8	6.26/0.8	7.1/0.8	10.1/0.8	12.7/0.8	10.1/0.8	12.7/0.8	15.2/0.8	20.1/0.8	24.0/0.8
		2.52/1	3.07/1	4.53/1	5.8/1	6.47/1	8.5/1	11.3/1	8.5/1	11.3/1	14.3/1	17.5/1	21.0/1.0
		2.3/1.2	2.84/1.2	3.9/1.2	5.06/1.2	5.8/1.2	7.69/1.2	10.0/1.2	7.69/1.2	10.0/1.2	12.9/1.2	16.0/1.2	18.3/1.2
Cooling mode		Air cooled	Air cooled	Air cooled	Air cooled	Air cooled	Air cooled	Air cooled	Air cooled	Air cooled	Air cooled	Air cooled	Air cooled
Drive mode		Directly connected	Directly connected	Directly connected	Directly connected	conveyor	conveyor	conveyor	Directly connected	Directly connected	Directly connected	Directly connected	Directly connected
Starting mode		Y-Δ	Y-Δ	Y-Δ	Y-Δ	Direct	Y-Δ	Y-Δ	Y-Δ	Y-Δ	Y-Δ	Y-Δ	Y-Δ
Length×Width×Height (mm)	L	1280	1280	1350	1500	1500	1900	1900	1900	1900	2000	2200	2200
	W	760	760	880	970	970	1200	1200	1200	1200	1200	1550	1550
	H	1200	1200	1220	1350	1350	1580	1580	1580	1580	1500	2000	2000
Net weight	Kg	585	635	730	910	980	1610	2650	1500	1700	1920	2575	2720
Noise	dB (A)	63±2	65±2	65±2	65±2	68±2	68±2	72±2	65±2	68±2	68±2	68±2	72±2
Diameter of outlet pipe		G1 ¹ / ₄ "	G1 ¹ / ₄ "	G1 ¹ / ₄ "	G1 ¹ / ₂ "	G1 ¹ / ₂ "	G2"	G2"	G2"	G2"	G2"	DN65	DN65

Table 1 -Continue

Type		XLAM 7.5A	XLAM 10A	XLAM 15A	XLAM 20A	XLAM 25A	XLAM 30A	XLAM 40A	XLAM 50A	XLAM 60A	XLAM 75A	XLAM 100A	XLAM 150A	XLAM 175A
Motor power	KW	5.5	7.5	11	15	18.5	22	30	37	45	55	75	110	132
Air displacement/exhaust pressure	(m ³ /min) /Mpa	0.9/0.7	1.2/0.7	1.65/0.7	2.55/0.7	3.22/0.7	3.6/0.7	5.2/0.7	6.58/0.7	7.36/0.7	10.8/0.7	13.5/0.7	21.6/0.7	25.2/0.7
		0.8/0.8	1.1/0.8	1.53/0.8	2.25/0.8	3.01/0.8	3.56/0.8	5.06/0.8	6.26/0.8	7.1/0.8	10.1/0.8	12.7/0.8	20.1/0.8	24/0.8
		0.69/1.0	0.95/1.0	1.32/1.0	1.82/1.0	2.52/1.0	3.07/1.0	4.53/1.0	5.8/1.0	6.47/1.0	8.5/1.0	11.3/1.0	17.5/1.0	21/1.0
		0.6/1.25	0.8/1.25	1.1/1.25	1.55/1.25	2.3/1.25	2.84/1.25	3.9/1.25	5.06/1.25	5.8/1.25	7.69/1.25	10/1.25	16/1.25	18.3/1.25
Cooling mode		Air cooled	Air cooled	Air cooled	Air cooled	Air cooled	Air cooled	Air cooled	Air cooled	Air cooled	Air cooled	Air cooled	Air cooled	Air cooled
Drive mode		Directly connected	Directly connected	Directly connected	Directly connected	Directly connected	Directly connected	Directly connected	Directly connected	Directly connected	Directly connected	Directly connected	Directly connected	Directly connected
Starting mode		Y-△	Y-△	Y-△	Y-△	Y-△	Y-△	Y-△	Y-△	Y-△	Y-△	Y-△	Y-△	Y-△
Length×Width×Height (mm)	L	840	840	910	910	1000	1000	1100	1150	1150	1900	1900	2200	2200
	W	600	600	700	700	750	750	900	950	950	1200	1200	1550	1550
	H	880	880	1000	1000	1090	1090	1200	1360	1360	1580	1580	2000	2000
Net weight	Kg	185	205	245	255	370	390	580	630	660	1350	1450	2200	2250
Noise	d B(A)	62±2	62±2	63±2	63±2	63±2	65±2	65±2	65±2	68±2	68±2	72±2	68±2	72±2
Diameter of outlet pipe		G3/4"	G3/4"	G3/4"	G3/4"	G1 ¹ / ₄ "	G1 ¹ / ₄ "	G1 ¹ / ₄ "	G1 ¹ / ₂ "	G1 ¹ / ₂ "	G2"	G2"	DN65	DN65

Table 1 -Continue

Type		XLPM 7.5A	XLPM 10A	XLPM 15A	XLPM 20A	XLPM 25A	XLPM 30A	XLPM 40A	XLPM 50A	XLPM 60A	XLPM 75A	XLPM 100A	XLPM 150A	XLPM 175A
Motor power	KW	5.5	7.5	11	15	18.5	22	30	37	45	55	75	110	132
Air displacement/exhaust pressure	(m ³ /min) /Mpa	0.9/0.7	1.2/0.7	1.65/0.7	2.55/0.7	3.22/0.7	3.6/0.7	5.2/0.7	6.58/0.7	7.36/0.7	10.8/0.7	13.5/0.7	21.6/0.7	25.2/0.7
		0.8/0.8	1.1/0.8	1.53/0.8	2.25/0.8	3.01/0.8	3.56/0.8	5.06/0.8	6.26/0.8	7.1/0.8	10.1/0.8	12.7/0.8	20.1/0.8	24/0.8
		0.69/1.0	0.95/1.0	1.32/1.0	1.82/1.0	2.52/1.0	3.07/1.0	4.53/1.0	5.8/1.0	6.47/1.0	8.5/1.0	11.3/1.0	17.5/1.0	21/1.0
		0.6/1.25	0.8/1.25	1.1/1.25	1.55/1.25	2.3/1.25	2.84/1.25	3.9/1.25	5.06/1.25	5.8/1.25	7.69/1.25	10/1.25	16/1.25	18.3/1.25
Cooling mode		Air cooled	Air cooled	Air cooled	Air cooled	Air cooled	Air cooled	Air cooled	Air cooled	Air cooled	Air cooled	Air cooled	Air cooled	Air cooled
Drive mode		Directly connected	Directly connected	Directly connected	Directly connected	Directly connected	Directly connected	Directly connected	Directly connected	Directly connected	Directly connected	Directly connected	Directly connected	Directly connected
Starting mode		Soft start	Soft start	Soft start	Soft start	Soft start	Soft start	Soft start	Soft start	Soft start	Soft start	Soft start	Soft start	Soft start
Length×Width×Height (mm)	L	840	840	910	910	1000	1000	1100	1150	1150	1900	1900	2200	2200
	W	600	600	700	700	750	750	900	950	950	1200	1200	1550	1550
	H	880	880	1000	1000	1090	1090	1200	1360	1360	1580	1580	2000	2000
Net weight	Kg	185	205	245	255	370	390	580	630	660	1350	1450	2200	2250
Noise	d B(A)	62±2	62±2	63±2	63±2	63±2	65±2	65±2	65±2	68±2	68±2	72±2	68±2	72±2
Diameter of outlet pipe		G3/4"	G3/4"	G3/4"	G3/4"	G1 ¹ / ₄ "	G1 ¹ / ₄ "	G1 ¹ / ₄ "	G1 ¹ / ₂ "	G1 ¹ / ₂ "	G2"	G2"	DN65	DN65

Table 1 -Continue

Type		XLAMTD 7.5A	XLAMTD 10A	XLAMTD 15A	XLAMTD 20A	XLPMTD 7.5A	XLPMTD 10A	XLPMTD 15A	XLPMTD 20A
Motor power	KW	5.5	7.5	11	15	7.5	11	15	15
Air displacement/exhaust pressure	(m ³ /min) /Mpa	0.9/0.7	1.2/0.7	1.65/0.7	2.55/0.7	1.2/0.7	1.65/0.7	2.55/0.7	2.55/0.7
		0.8/0.8	1.1/0.8	1.53/0.8	2.25/0.8	1.1/0.8	1.53/0.8	2.25/0.8	2.25/0.8
		0.69/1.0	0.95/1.0	1.32/1.0	1.82/1.0	0.95/1.0	1.32/1.0	1.82/1.0	1.82/1.0
		0.6/1.25	0.8/1.25	1.1/1.25	1.55/1.25	0.8/1.25	1.1/1.25	1.55/1.25	1.55/1.25
Cooling mode		Air cooled	Air cooled	Air cooled	Air cooled	Air cooled	Air cooled	Air cooled	Air cooled
Drive mode		Directly connected	Directly connected	Directly connected	Directly connected	Directly connected	Directly connected	Directly connected	Directly connected
Starting mode		Y-△	Y-△	Y-△	Y-△	Soft start	Soft start	Soft start	Soft start
Length×Width×Height (mm)	L	1800	1800	1800	1800	1800	1800	1800	1800
	W	600	600	700	700	600	600	700	700
	H	1560	1560	1750	1750	1560	1560	1750	1750
Net weight	Kg	370	380	505	515	375	385	515	525
Noise	d B(A)	62±2	62±2	63±2	62±2	62±2	62±2	62±2	62±2
Diameter of outlet pipe		G3/4"	G3/4"	G3/4"	G3/4"	G3/4"	G3/4"	G3/4"	G3/4"
Tank volume (m ³)		0.5	0.5	0.5	0.5	0.5	0.5	0.5	0.5

As the products of the company are continuously optimized and upgraded, the information is subject to changes in specifications and relevant data.

4 Main Structures

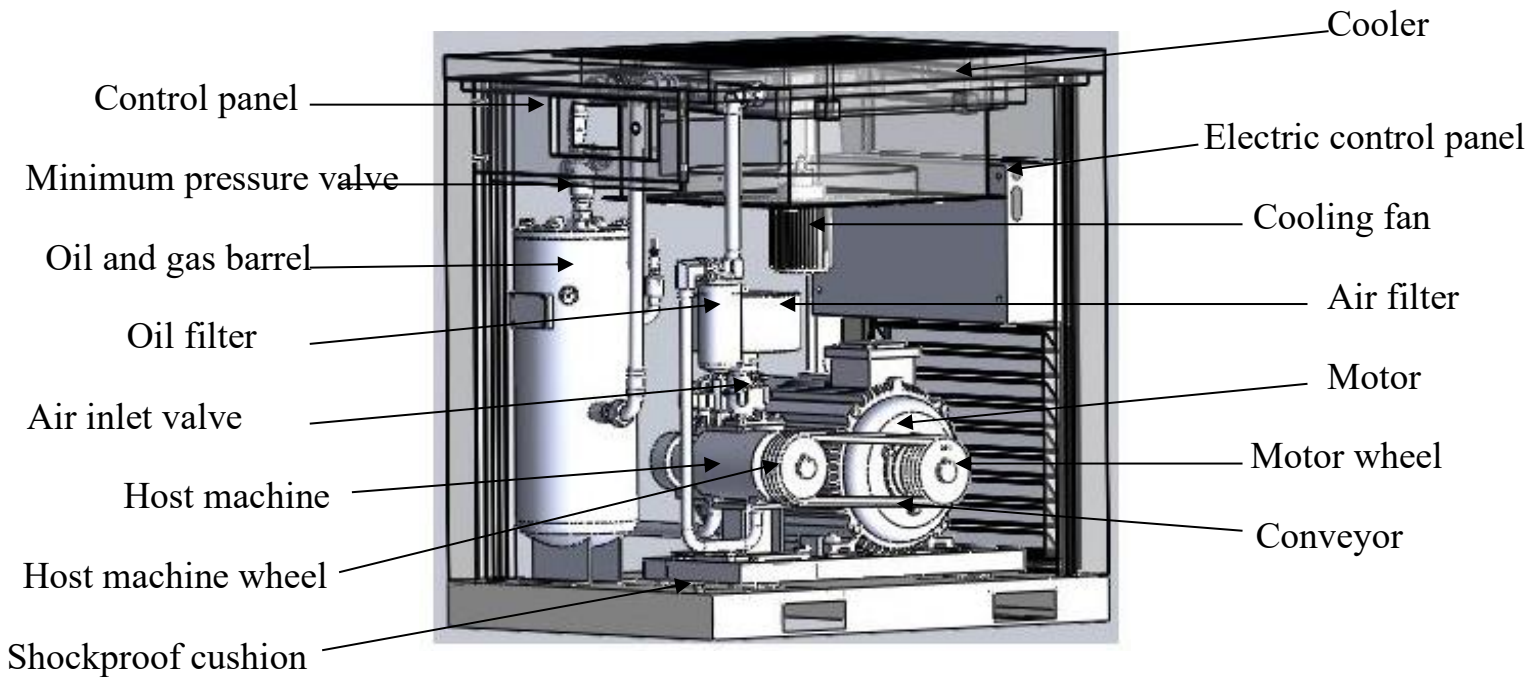

Diagram 1. Conveyor-Type Screw Compressor

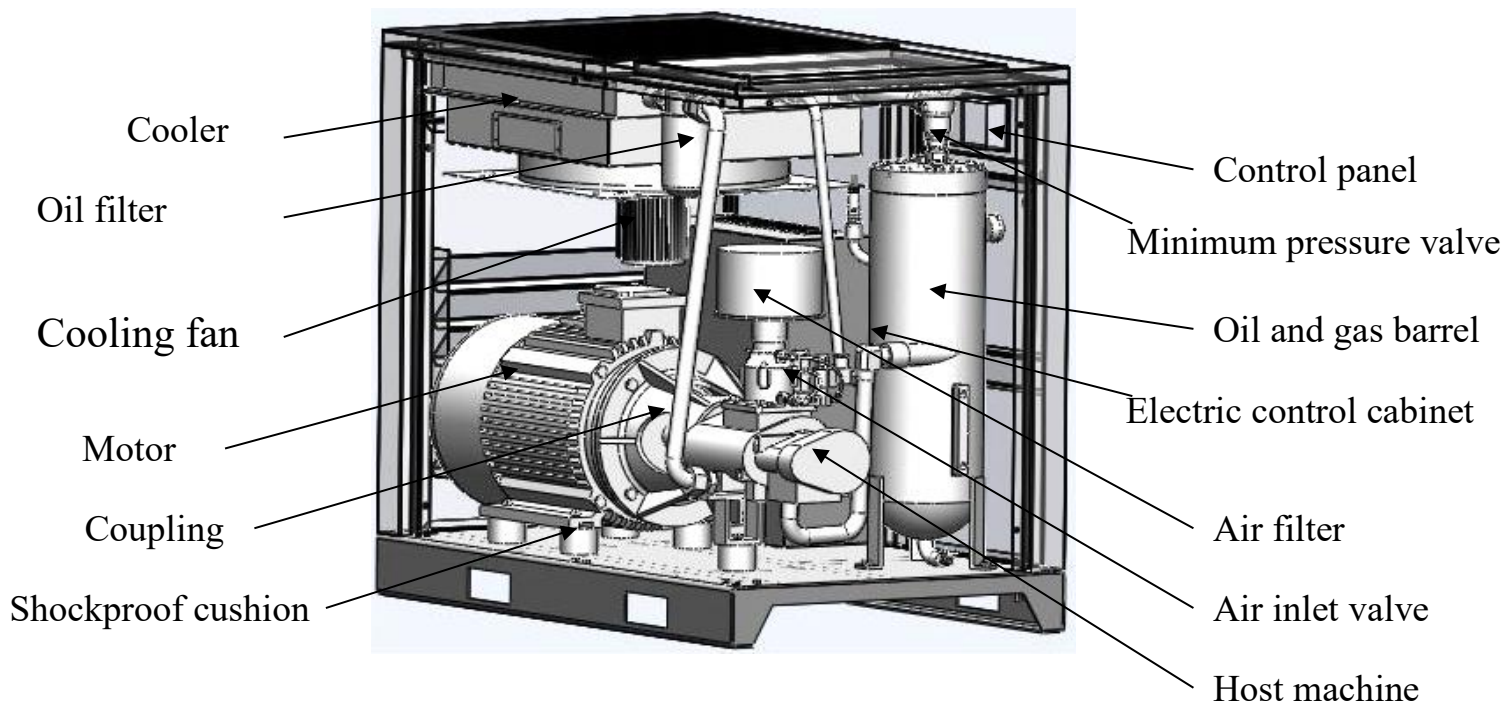

Diagram 2 Directly connected -type screw compressor

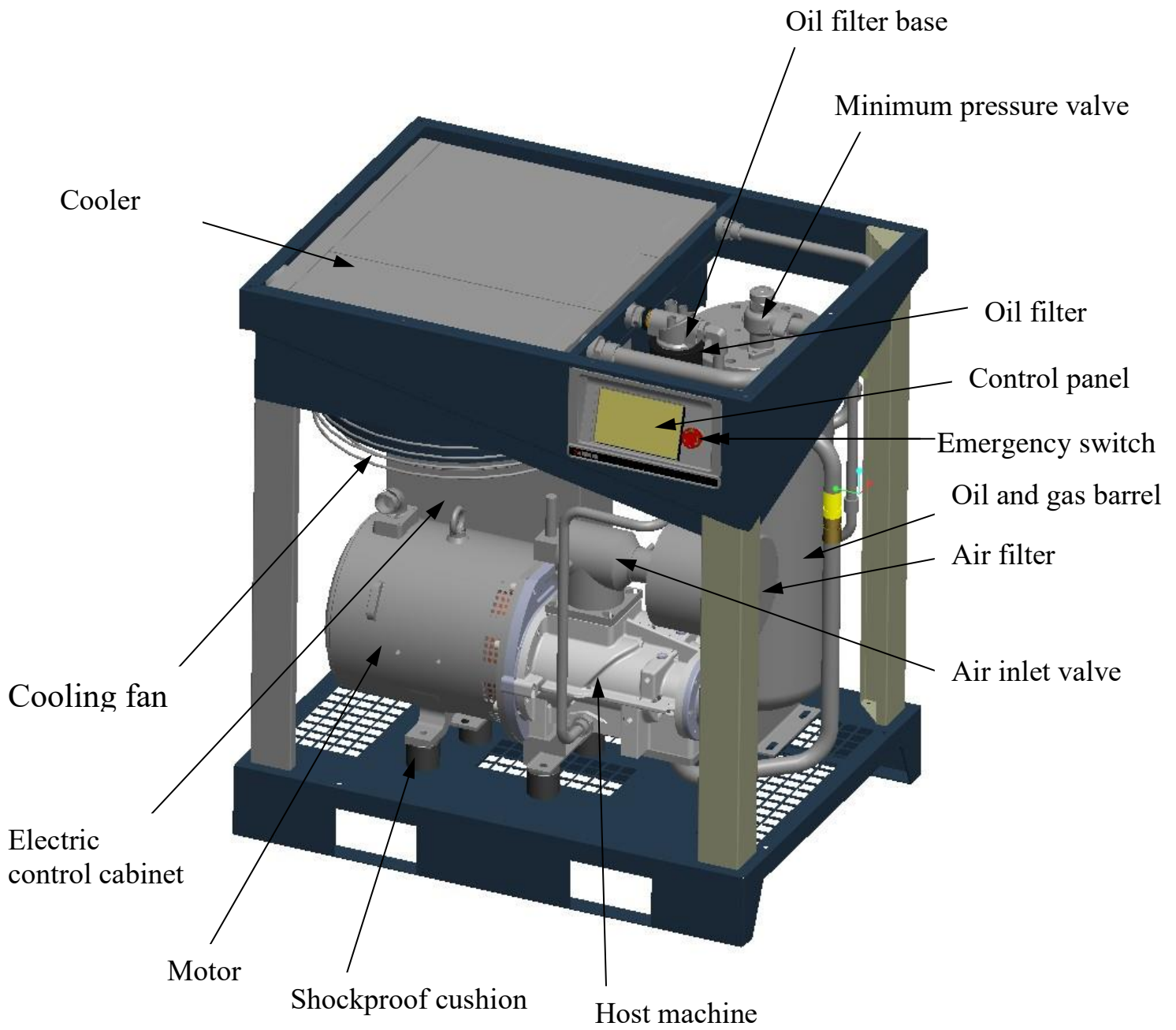

Diagram 3 Directly connected -type screw compressor

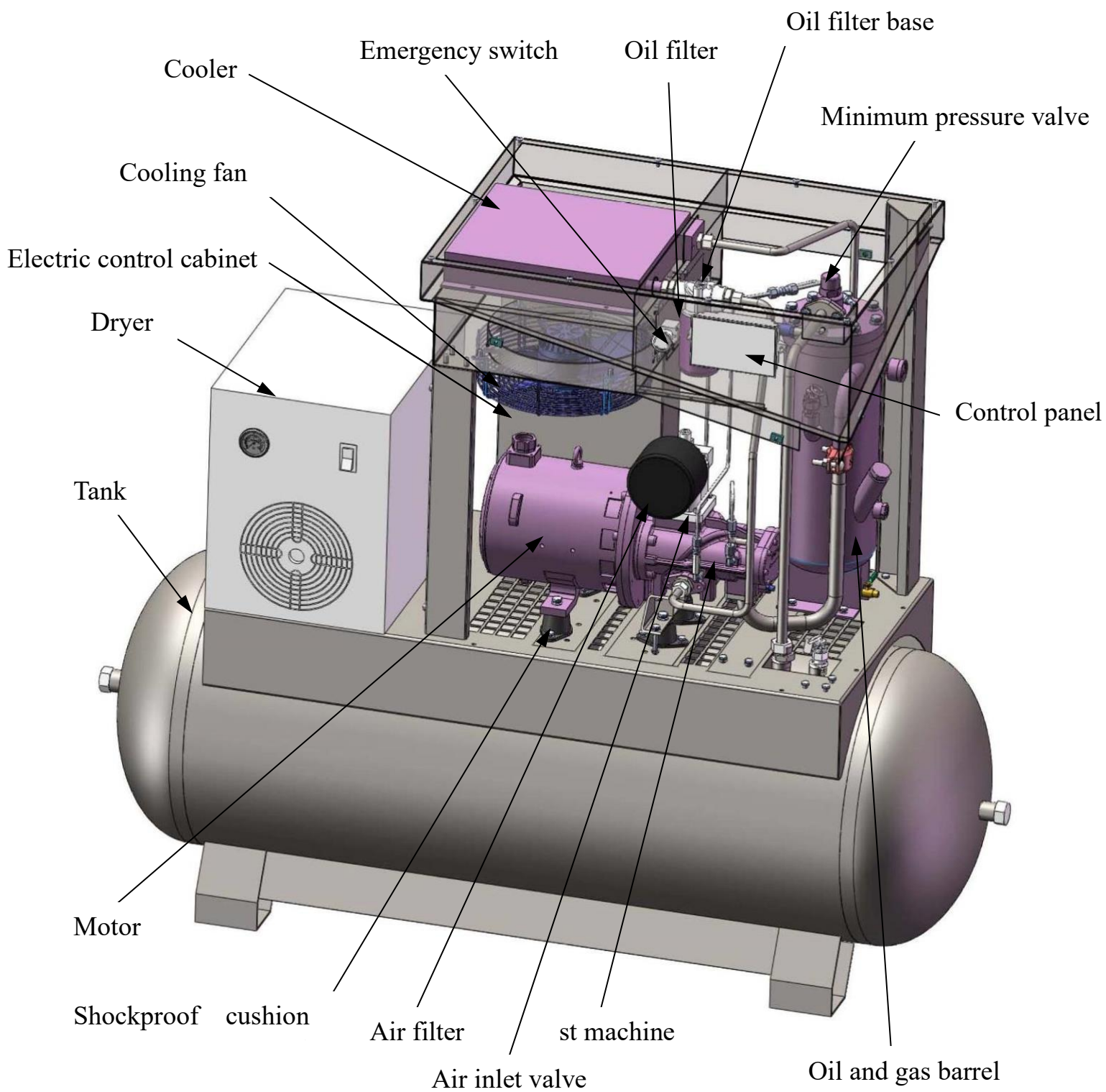

Diagram 4 Directly connected -type screw compressor

5 Pipeline Flow Diagrams

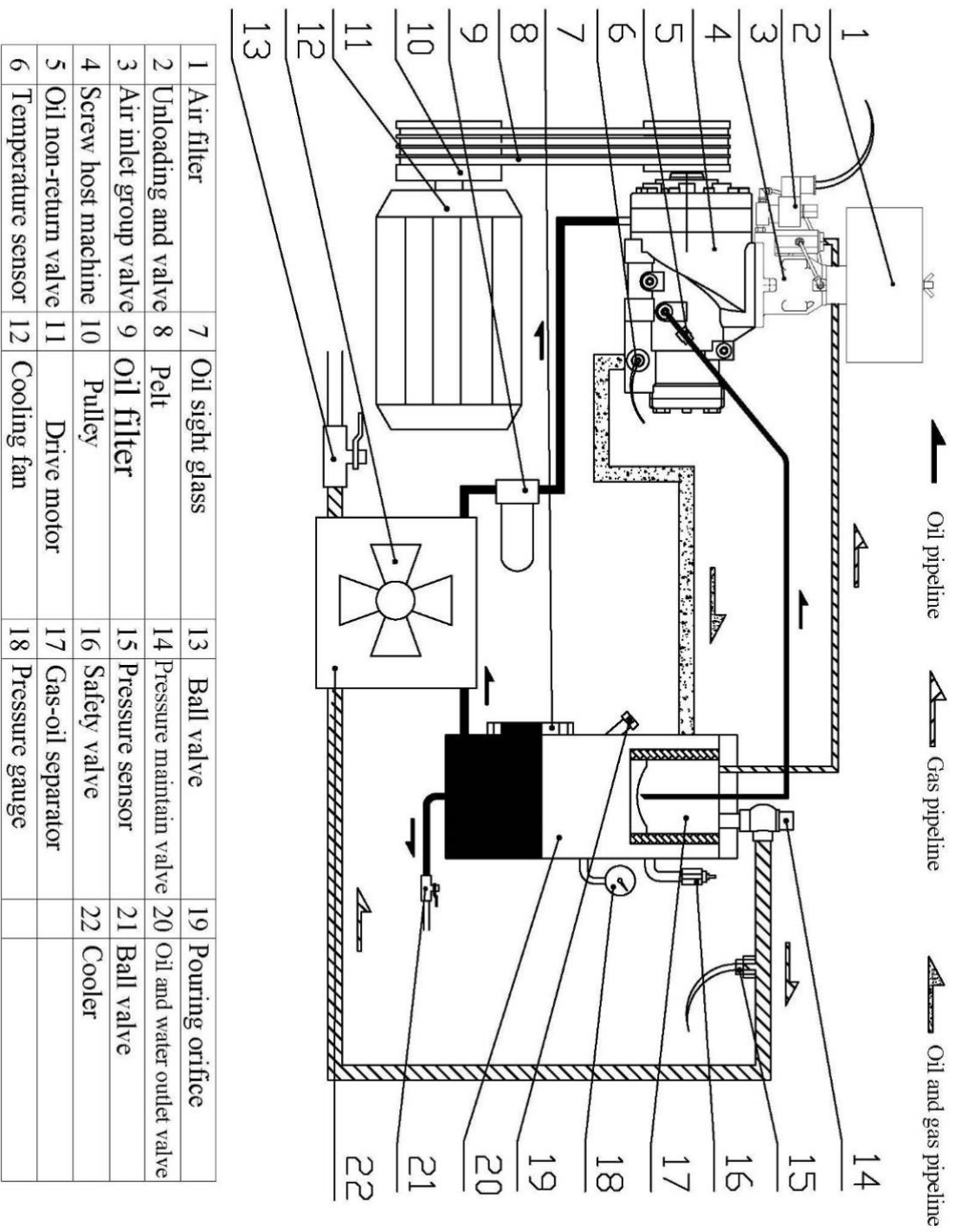

Diagram 5 Conveyor-type screw compressor flow diagram

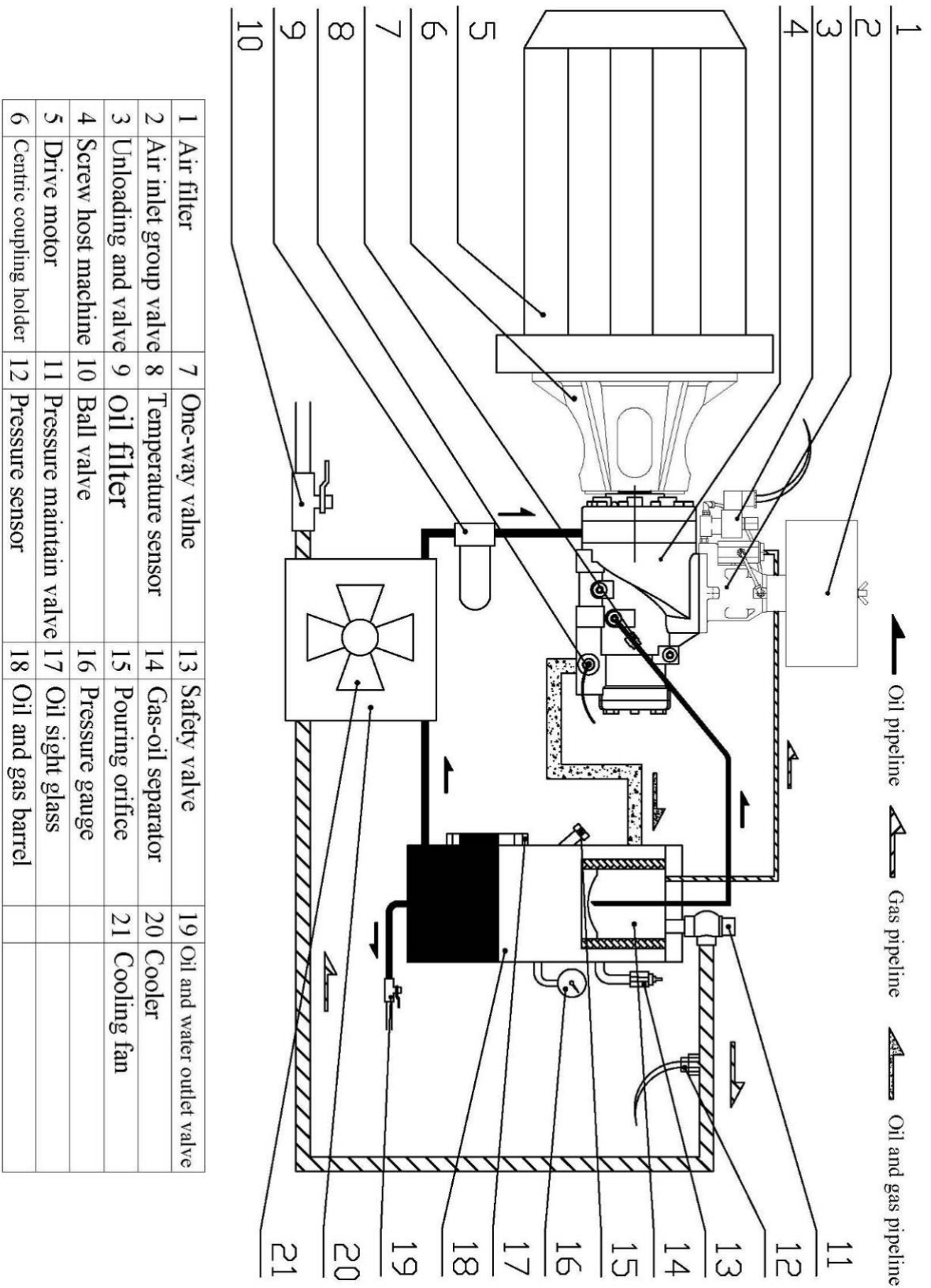

Diagram 6 Directly connected screw compressor flow diagram

6 Electric Principle Diagram

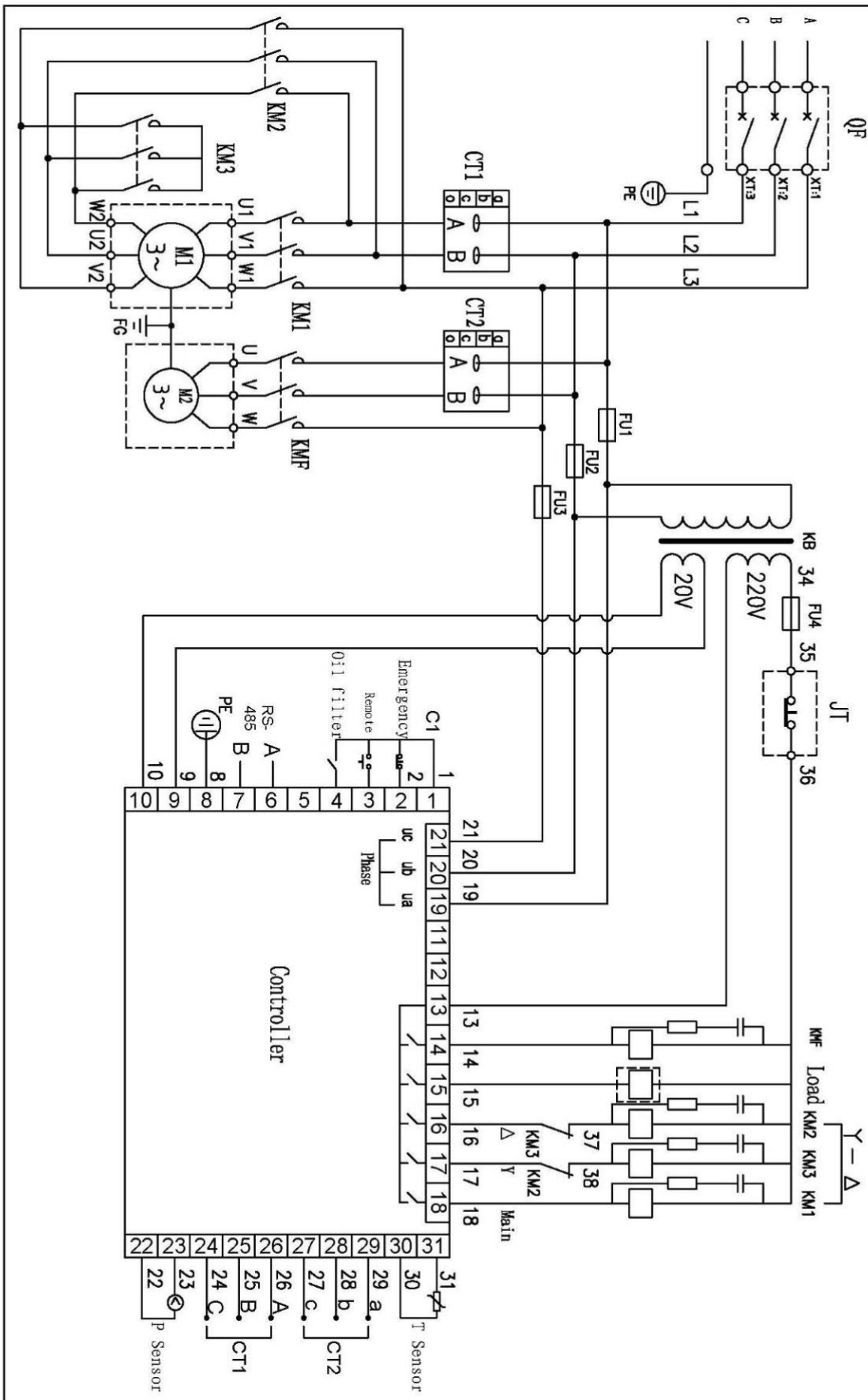

Diagram7 Electric principle diagram for split type main controller

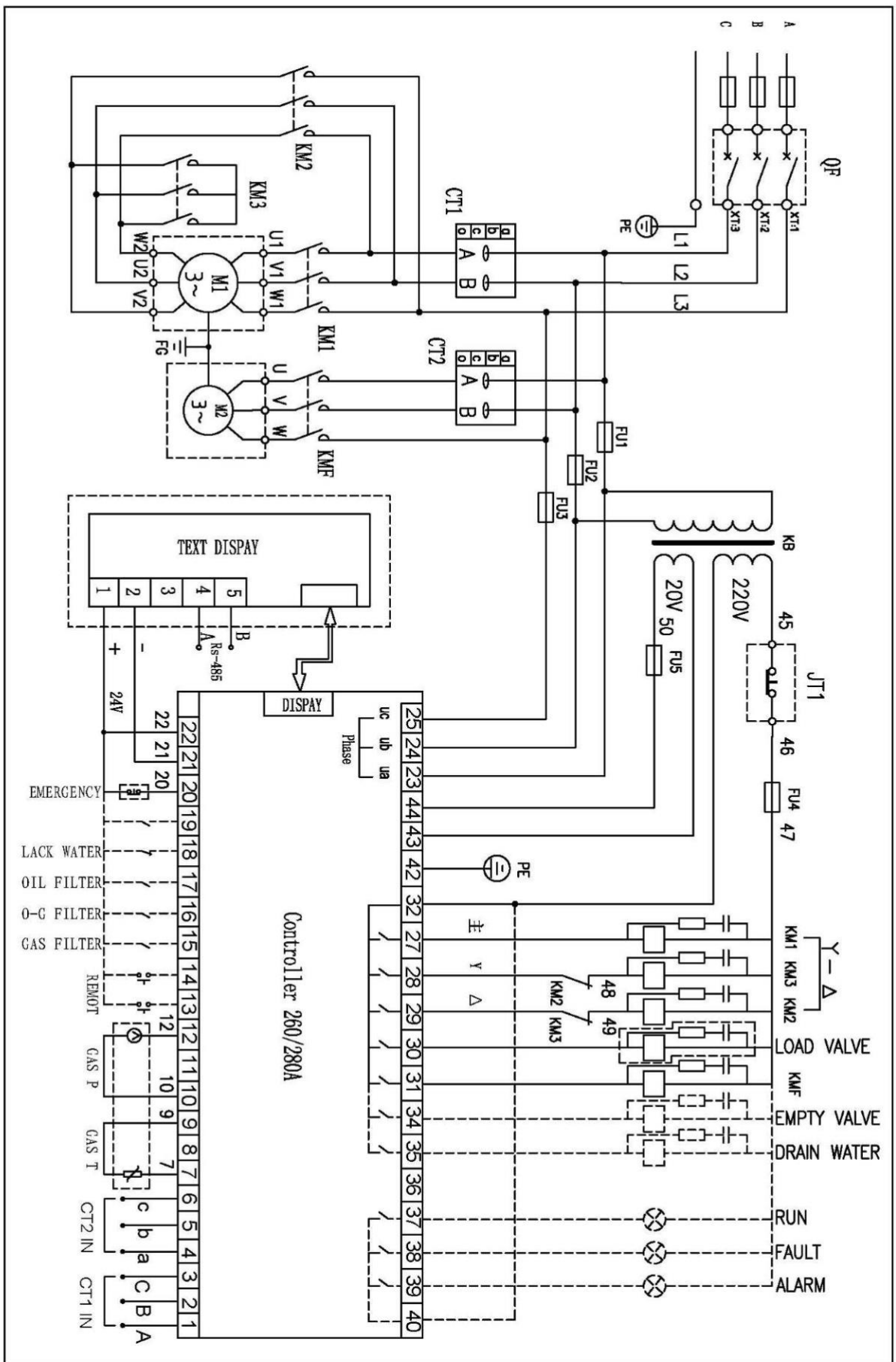

Diagram 8 Integral-type main controller electric principle diagram

7 Warnings and Announcements

7.1 Power distribution for the machine

a) According to the power, voltage frequency and other characteristics of the air compressor, select and use matched power supply and suitable power line (If conditions permit, excellent power line with properties of anti-high temperature and anti-aging shall be equipped to avoid breakdown in the air compressor caused by power line or power).

b) Cross area of the power line shall be no less than the data in Table 2.

Table 2 Minimum cross area of the power line (Copper wire mm²)

Code of the product	Motor power (KW)	Cross area (mm ²)	Code of the product	Motor power (KW)	Cross area (mm ²)
XLD30A	22	16	XL25A	18.5	16
XLD50A	37	35	XL30A	22	16
XLD75A	55	50	XL40A	30	25
XLD100A	75	70	XL50A	37	35
XL10A	7.5	6	XL60A	45	35
XL15A	11	10	XL75A	55	50
XL20A	15	16	XL100A	75	70

c) Proper air switch shall be selected and equipped by professional electrician according to the power and voltage of the air compressor to protect the power electrical system for safety guarantee, which is shown in Picture 9



Picture 9 Air Switch

d) The air compressor must be reliably grounded to avoid the dangers caused by electricity leakage and static electricity.

e) Air compressor with large displacement shall use a separate set of power supply unit to avoid impact on the normal operation of other equipments, or it goes against the normal operation of the air compressor(It causes to the operation of screw protective devices)

7.2 Announcements

a) In order to avoid the damage caused by jolt during the process of storage and transportation has been screwed when it leaves the factory. The user has to lock in the transportation fastening screw and loosen the fasteners before using the equipments, which is shown in Picture 10

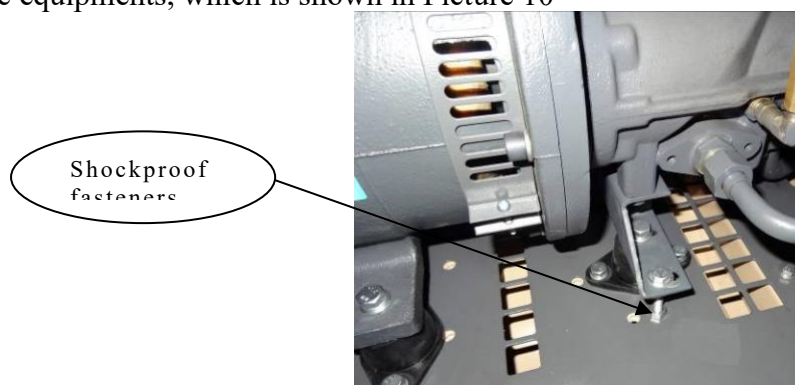

Picture 10

- b) Debugging of the new machine must be operated by appointed or authorized person by the company.
- c) Operators must read, comprehend and follow the relevant operating procedures, announcements and maintenance specifications in the manual.
- d) The air compressor without air storage tin can only be used after being equipped with air storage tin.
- e) The air compressor shall not be arbitrarily altered or set the rated operating voltage to avoid overload damage to the motor.
- f) Air compressor shall be operated indoor, with good ventilation and a temperature that is less than 45°C.
- g) The end of the inlet wire of power supply shall be equipped with a terminal to guarantee that the bolt in the terminal is fixed and won't become flexible. The wire must be installed by professional electricians(As shown in Picture 11).



Picture 11







- h) It is strictly prohibited that the compressor operates under a pressure less than 0.4Mpa in long-term basis.
- i) Keep the lubricating oil between the range of upper and lower limits of the oil indicator. We suggest use Xinlei Brand special purpose lubricating oil. Mixture of different brands of lubricating oils is strictly prohibited to avoid serious accident caused by coke accumulation in pipeline system.
- j) It is strictly prohibited to examine and repair the electrical equipment and circuit under the condition that the power supply is not off.
- k) It is strictly prohibited to examine and repair the pressure volume and pressure pipeline.
- l) Timely get rid of the moisture in gas and oil barrel.
- m) The exhaust temperature shall be between 70 and 105°C.
- n) Cleansers which are inflammable, explosive and volatile cleaners cannot be used to maintain and clean the





parts. Safe dissolvant free from corrosion shall be used instead.

o) If there is breakdown alarm in the compressor, please don't start up the machine forcefully. Please timely find out the cause and deal with it accordingly.

7.3 Warning symbols

Table 3

S.N.	Name	Symbol	Description
1	Safety in electricity utilization		Make sure the working supply voltage is off during operation
2	Danger!Electricity !		Watch out charged body ,leakage body and other electrical parts
3	Danger warning		Pay attention to and be careful about relevant warning information
4	Reading the instruction		Read the instruction before operation
5	Ignition hazard		Inflammable and explosive materials shall be away form the machine
6	Exploration hazard		Please don't weld or repair the air storage tank

S.N.	Name	Symbol	Description
7	Electric shock hazard		Please don't place the equipment in wet places or outdoors to avoid electricity leakage due to reduction in electrical insulation resistance
8	No air leakage		No air leakage here
9	Caution, hand injury		Don't touch transmission part
10	Rotational direction of the motor		Check rotational direction of the motor during the process of first starting up or changing wire to avoid serious breakdown to the machine
11	Danger, hot!		Hot surface, avoid burns

8 Equipment Installations

Installation site choosing and heat elimination and ventilation system

An installation site plan must be made to correctly use the air compressor to create good environment for its operation and maintenance. A reasonable site must meet the following requirements.

- Air compressor must be installed indoor, which is clean, dry, ventilated, dust free and harmful gases free.
- Operating environment temperature shall not exceed 45°C. And the relative humidity of the surrounding atmosphere shall be less than 80%.
- The floor for installation shall be solid, smooth and horizontal.
- If the planning site is an air compressor station, proper compressed air processing devices, valves, pipelines and pressure containers shall be equipped according to relevant provisions. In order to assure good heat dissipation and maintenance space, the distance between the air compressor and the wall shall be no less than one meter and space of more than 1.5 meters shall be reserved on the top to avoid wind bridge which is formed by the outlet hot wind and inlet cold wind. Exhaust devices shall be equipped in the machine room which is badly ventilated.

9 Equipment Operation

9.1 Transportation shockproof fixation bolt shall be loosened before the operation (Please refer to what is stated in item 7.2 in announcements)

9.2 Air compressor can only be come into service when it is equipped with air storage tank(as what is shown in Table 1-Main Technical Data).

9.3 Test run of the new machine

- Testing voltage on page 12, item 7.1-a, shall meet the requirements in relevant provisions. According to

the requirement of item 7.1-d on page 12, it shall be grounded. According to the items 7.1-b and c on page 12, it shall be connected to the power line. The cross area and length of the power line shall meet the provisions in Table 2 on page 12.

b) Check the oil level in gas and oil barrel to see if it is between the upper and lower limits.

c) To guarantee safety of starting up, it shall be firstly confirmed that there are no personnel, tools and inflammable and explosive materials in the unit.

d) Pour approximate 0.2 liters lubricating oil which is specially used for air compressor to the air inlet valve and turn the handpiece if the machine for several turns to avoid damage in dynamic and static tray in air compressor due to oil shortage.(A funnel with net is used for filtrating to prevent foreign matters from entering the handpiece.)

e) Charge electricity to the control panel in air compressor

f) Trial operation test: Trial operation shall be done for two or three times before the formal operation. The purpose of Trial operation, starting up the machine and shut it down immediately, is to check if the rotating direction of the air compressor is correct or not and if there is abnormal noise and vibration.

g) Normal operation: Press the start button again to start the operation of the air compressor.

h) After the starting up of the machine, motors with power more than 11kw shall be set as Y- Δ starting up, the initial operation is slowly speeded up in way of Y shape and automatically changed to quick speeding up in way of Δ shape.

i) Stop: When the stop button is pressed, the air compressor stops to run. The compressed air in pressure pipeline will be discharged by load relief valve when the machine is stopped, getting ready for the next no load starting up of the equipment. It is a normal phenomenon if some weak sound of air discharging can be heard.

9.4 Safety protection

a) Motor protection

Table 4

S.N.	Breakdown description	Breakdown display	Causes
1	Phase shortage	Shutdown	Breakdown in power supply, contactor and motor circuit
2	Overload	Shutdown	Increase in load capacity or mechanical breakdown
3	Locked-rotor	Shutdown	Increase in load capacity or mechanical breakdown
4	Imbalance	Shutdown	Three- phase voltage of the power supply is not stable or circuit breakdown in motor
5	Short circuit	Shutdown	Serious electricity leakage, short circuit between circles of the motor or error in current setting

b) Air (Oil) exhaust standard exceeding protectio

When temperatures of air (oil) exhausting reach the set warning temperature, there will be alerting information on the controller and give an alarm. When the temperature reaches set breakdown temperature, the controller execute the order and shutdown

When the phase sequence of the three-phase power supply is different from that set in the controller, the controller is unable to output the starting up signal and the motor cannot start operation. For the time being, you have to exchange any two power lines and see the rotating direction of the motor.

c) Exhaust pressure overpressure protection

When the exhaust pressure is high than the upper limit value, the controller execute the order and shutdown

d) Sensor failure protection

When pressure sensor and temperature sensor are in breakdown of disconnection, the controller execute the order and shutdown.

10 Operations and Maintenance

10.1 Routine operation and maintenance (According to provisions in Table 5)

10.1.1. Examining and maintaining before operation

- a) Check to see if the equipment is clean and complete.
 - b) Check and maintain the intact of the electrical elements and firmness of the grounding.
 - c) Check and maintain the reliability of the fasteners.
 - d) Check and adjust the tension of the belt and change it if necessary.
 - e) Check, adjust and change the coupling or bumper block if necessary.
 - f) Check, add and change the lubricating oil if necessary.
- Oil level shall be between the upper and lower red line of the oil indicator, as what is shown in Picture 12.
-



- Special lubricants for screw machine as shown in Picture 1 should be used.

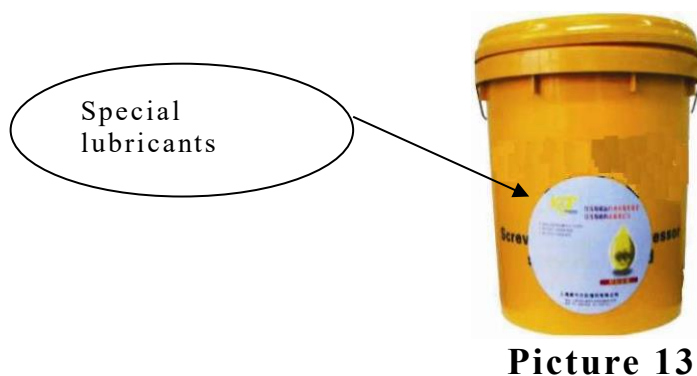

- Refueled oil should be filtered through Cleaned funnel(Filtering precision is 14um)

➤ The used oil should be discharged before the change of lubricant as shown in Picture 14.



图 14

g) Check to see if it is necessary to discharge the condensate water in the gas and oil barrel. (Slightly open the liquid discharge valve on the bottom of gas and oil barrel and discharge the condensate water till the lubricating oil flows out.)

h) Check, clean and replace the filter element of the air filter if necessary as shown in Picture 15.

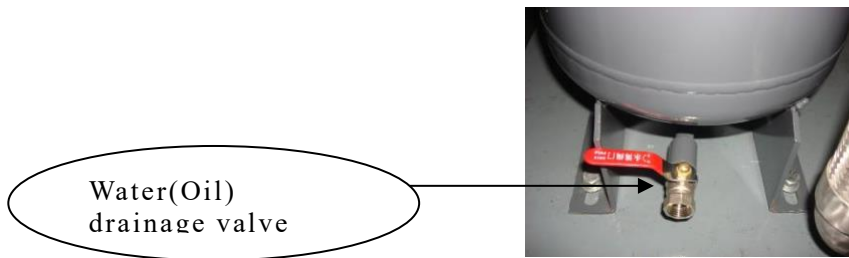
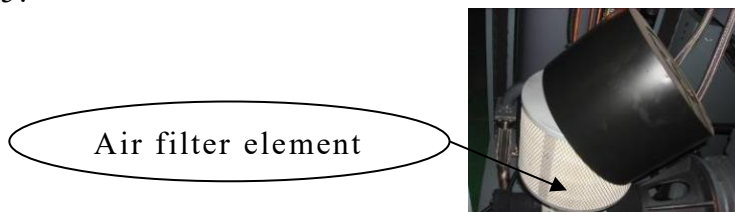

Picture 15

i) Check, clean and replace the oil-gas separator if necessary as shown in Picture 16.

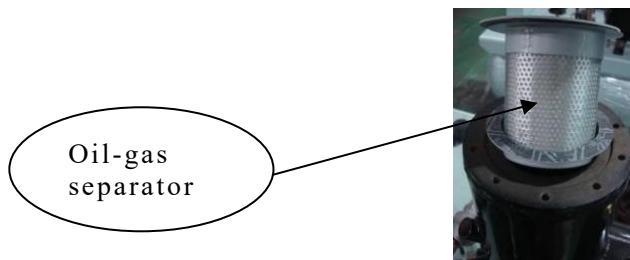

Picture 16

j) Check, clean and replace the oil filter if necessary as shown in Picture 17.

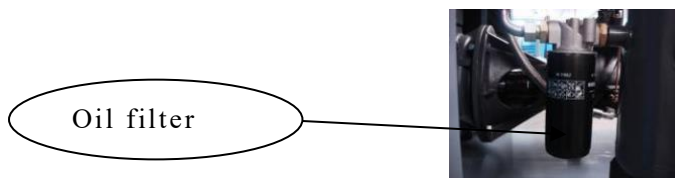

Picture 17

m) Check and clean the cooler if necessary as shown in Picture 18.

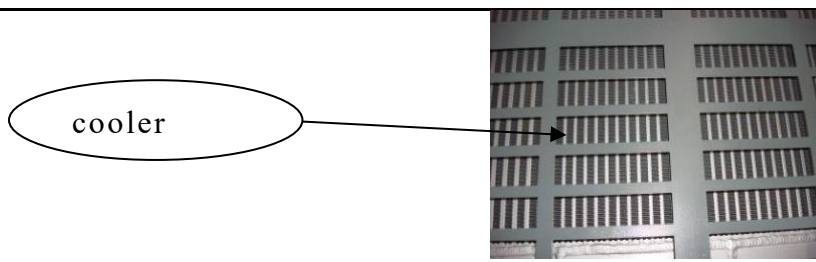

Picture 18

10.1.2 Starting up Checking

- a) Check the operating button to see if it is in normal condition.
- b) Check whether there are phenomena of abnormal noise vibration and oil leakage.
- c) Check the instruments of pressure gauge, oil thermometer, ammeter and indicator light etc. to see if they are in normal condition.
- d) Check the oil return pipe to see if it is in normal condition.
- e) Check the pressure of the automatic stop and that starting up to see if it is in normal condition.
- f) Check the unloading valve to see if it is deflating or not when the machine stopped. Check the exhaust temperature to see if it is in normal condition.
- g) Check to see if th temperature is in normal condition

- h) Check the voltage and electric current to see if they are in normal condition.

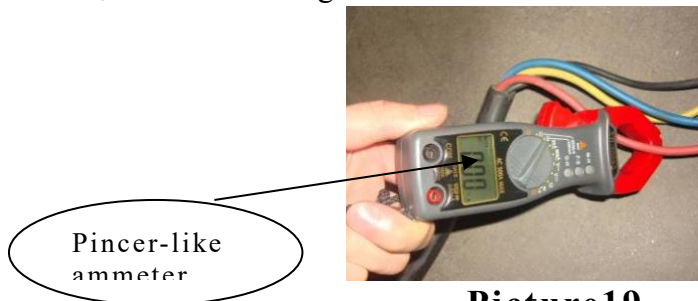

Picture19

- i) Check, clean and replace the safety valve if necessary .
Check the motor insulation resistance .
- k) Record the voltage, current , air pressure, exhaust temperature and oil level every day and take notes of the working time, maintenance status and abnormalities per shift .

Maintenance plans

Table 5

S.N.	Checking Items	Working content	Maintenance cycle						Remarks
			Day	Week	Month	Half year	A year	Two years	
1	Fastener	Check the bolts and transmission components	☆						The bolts and transmission components can't fall off or loosen.
2	Coupling	Check the coupling	☆						Concentricity is normal with no damage.
3	Strainer of oil return pipe	Check the strainer			★				No sundries
4	Condition of oil return in transparent return pipe	Make sure the oil return is normal	☆						Oil return is fluent
5	Unloading valve	Make sure the machine is stopped and deflating	☆						Normal stop, unloading and deflating
6	☐ Lubricating oil	Check the level and quality of oil	☆						The oil level should be within the alerting line, without oxidation discoloration
7	Air (oil) exhausting temperature	Make sure the venting temperature	☆						The normal temperature is between 70°C and 105°C
8	Voltage and current	Check the voltage and current .	☆						Within 1.2 times of that of the rated current
9	☐ Air filter	Cleaning		☆					Replace the filter element only.
10	Drainage in Gas and oil barrel	Water drainage		☆					Discharge from the oil discharge valve
11	dustproof gauze	Cleaning and maintenance			☆				Take out and clean
12	Pipeline system	Check the situation of oil leakage and air leakage.	☆						No phenomenon of oil leakage
13	Circuit system	Line terminal or displaying information	☆						No phenomena of information alarming or wire decrustation
14	☐ Oil strainer	Checking and cleaning			☆				Replace the filter element only
15	Filter element of oil-gas separator	Cleaning and replacement			★				Replace the filter element only
16	Mechanical seal for the host machine	Checking the leakage	☆						The quantity of oil leakage is less than 1.5g/h

17	Motor insulation	Checking the insulation resistance					★		More than 2MΩ when the voltage is 500V
18	Relief valve	Checking the sensitivity of the action					☆		In condition of rated pressure, it can discharge when the discharging ring of the relief valve is pulled with a force less than 1 kg and the sundries are cleared off.
19	Pressures of automatic stop and automatic start up	Checking the sensitivity of the action	☆						Stop pressure and start-up pressure are in normal condition .
20	Cooler	Maintenance and cleaning	☆						Clean the surface dirt in the way of blowing
21	Indicator of the oil level indicator	Checking the clarity	☆						Replace it when the oil level is fuzzy .
22	Belt and pulley	Checking the firmness or replacement .	☆						Extrude the center of the belt with the thumb to make sure it is 10 to 15 mm and with no damage.

Notes : “☆”refers to parts that are maintained by users, “★”refers to parts that are entrusted to service center . “□”refers to parts that must be replaced after the new machine running continuously for 500 hours, then replace them after 3000 hours’ work.The maintenance parts are those whose working time are less than 6000 hours .

10.1.3 Processing method of long-term shutdown

10.1.3.1 Equipment should be sealed if it is shutdown for a long period of time.

- Clean the equipment and spread some antirust oil on the parts which are easy to be rusted .
- Electric equipment such as motor control panel etc., all Valves, tables, indicators shall be wrapped up with plastic paper or oil paper.
- The water in the oil cooler (gas and oil barrel), gas cooler and air storage tank shall be all discharged..
- Covering all the equipment with plastic paper or some other similar materials.
- Transportation fixed screw should be locked If the transfer storage space is changed .

10.1.3.2 To restart the sealed air compressor , the Motor insulation resistance should be measured first (No less than 1 MΩ).then do as the operating instructions on page 16 item 9.3.The air compressor sealed more than one year should replace the lubricant .

11 Breakdown and Elimination Table 6

S.N.	Breakdown phenomena	Causes	Breakdown elimination
1	Motor starting up failure	No input voltage or the voltage is in abnormal condition .	Check the power supply circuit
		Phase failure (The motor gives out "buzz-buzz" sound)	Check the power line terminal, electric controller and on-line terminals
		Connection error in power phase position	Adjust the phase-sequence and repair or replace the main controller
		Blownfuse	Check and make sure there is no error in circuit and replace the fuse
		Burning of AC contactor or failure	Repair or replace
		Failure of pressure switch (Pressure sensor)	Repair or replace
		Motor burning out and bearing failure	Repair or replace
		Clamping stagnation in dynamic tray in handpiece or block up caused by bearing failure	Repair or replace
		Temperature sensor operation protection	Find out the causes and eliminate the breakdown
Current protector operation protection	Find out the causes and eliminate the breakdown		
2	Story frequent starting up	Failure in starting up the time delay unit	Check and reset the time delay unit and main controller or replace it
		Serious leakage in pipeline	Check the leaking parts and eliminate the breakdown
		Volume of air storage tank is not large enough	Add air storage tanks or replace larger air storage tanks
3	Exhaust (oil) temperature is too high	Environmental temperature is too high	Increase the air volume in the unit room
		The cooler is dirty and with bad heat dissipation	Clean the cooler
		Blocking in oil pipeline	Check and get the pipe through
		Failure of temperature sensor	Repair and replace
		The lubricating oil is not enough	Add lubricating oil
		Failure in cooling fan	Repair or replace
4	Too low exhaust pressure	Failure in pressure switch, force sensor and main controller	Repair adjust and replace
		Too much air consumption	Repair the pipeline, buy more air compressors and control the air volume
		Serious leakage in pipeline	Repair and replace if necessary
		Blocking in air filter	Clean and replace the filter element
		Breakdown in air inlet valve	Repair or replace
		Blocking in oil-gas separator	Repair or replace
		Leakage in unloading solenoid valve	Repair or replace
		Slipping in V shape rotational belt	Repair,adjust and replace

5	Great consumption of lubricating oil	Blocking in oil return pipe	Disentangle or replace
		Warranty period of oil-gas separator is due	Clean or replace
		Too high lubricating oil level	Decrease the oil level
		Breakdown in minimum pressure valve	Repair or replace
		No use of special lubricating oil	Exchange the special lubricating oil
6	Abnormal noise and vibration	Fasteners become flexible. Host bearing wear or damage in motor	Repair or replace
		Conveyor wear	Replace the belt
		Wear or looseness in the coupling	Check,fasten or replace
		Foreign matters enter rotating parts such as handpiece, motor or fan	Repair or replace
7	Early deterioration in lubricating oil	Failure in empty the used lubricating oil	Empty the used oil and add new special lubricating oil
		No use of special lubricating oil	Exchange special lubricating oil
		Too high exhausting temperature	Increase air volume and decrease the environmental temperature or repair the temperature control valve and cooling system
8	Oil leakage in air filter when it is shutdown	Breakdown in air inlet valve	Repair or replace
		Gas return in minimum pressure valve	Repair or replace
		Unloading solenoid valve fails to deflate	Repair or replace
9	Great current or trip caused by slow rotation of the motor	Breakdown in handpiece, motor and the bearing	Repair or replace
		V shape rotation belt is too tight	Repair and adjust the handpiece
		Low input voltage(The wire is too long and the diameter is too small)	Adjust the wire
		Poor contact in circuit	Repair or replace
		Too great differential pressure in pipeline (Blocking in filter element)	Repair or replace
		Serious imbalance in three-phase voltage	Check and eliminate the breakdown
		Poor contact or current capacity of the breaker is not large enough	Repair or replace
		No use of special lubricating oil	Exchange for special lubricating oil
10	Failure of rotating cooling fan	Too high temperature, great current and operation of overload protector	Repair or replace
		Phase failure	Check the circuit and AC contactor
		Breakdown in temperature controller and main controller	Repair or replace
		Inconformity in three-phase resistance value (Motor burnt our)	Repair or replace
		Breakdown in fan bearing	Repair or replace

12 Directly-connected type screw machine

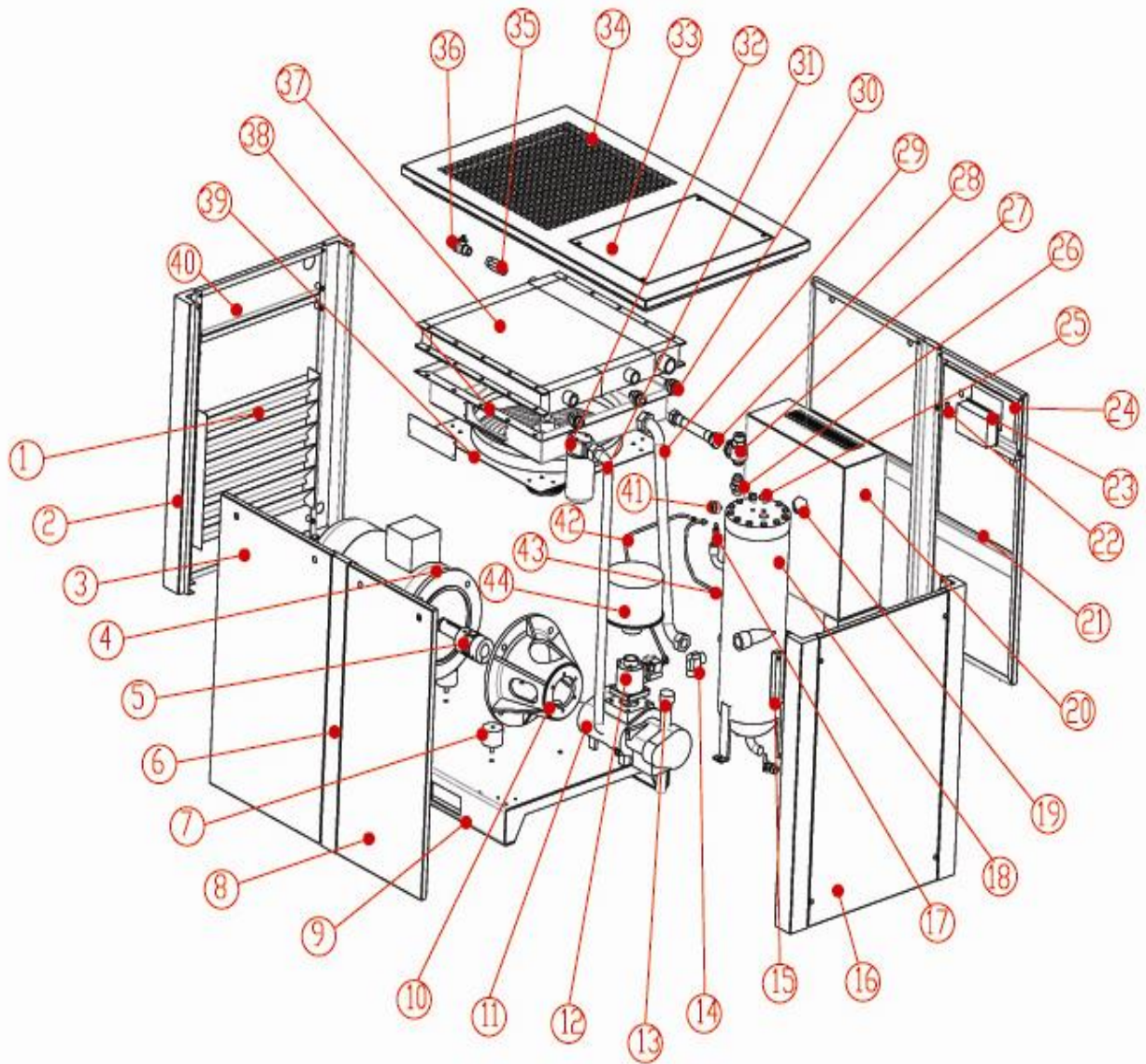

List of the parts of directly-connected type screw machine

S.N.	Name	Quantity	S.N.	Name	Quantity
1	Right shutter	1	24	Control shutter	1
2	Right frontside vertical shaft	1	25	Bend	1
3	Front and back right shutters	1	26	Adjustable pipe joint	1
4	Motor	1	27	Minimum pressure valve	1
5	Coupling	1	28	Air outlet pipe	1
6	Back-central gatepost	1	29	Head oil inlet	1
7	Anti-vibration pad	1	30	Oil inlet joint of the cooler	1
8	Back-left gatepost	1	31	Oil filter assembly	1
9	The main baseplate	1	32	Oil filter joint	1
10	Center bracket	1	33	Camp of the head cover	1
11	Screw handpiece	1	34	Head cover	1
12	Air inlet valve	1	35	Gas supply pipe	1
13	Exhausting pipe of handpiece	1	36	Ball valve	1
14	Bend	1	37	Fin type heat exchanger	1
15	Oil mirror	1	38	Wind cover assembly	1
16	Left shutter	1	39	Fan	1
17	Relief valve	1	40	Deflation opening board	1
18	Oil-gas barrel	1	41	Pressure gauge of the oil-gas barrel	1
19	Refueling cover of the oil-gas barrel	1	42	Fine oil differentiating return pipe	1
20	Electric control cabinet	1	43	Unloading pipe	1
21	Front-left shutter	1	44	Air filter assembly	1
22	Emergency "stop" button	1			
23	Controller	1			

13 Conveyor- type screw machine

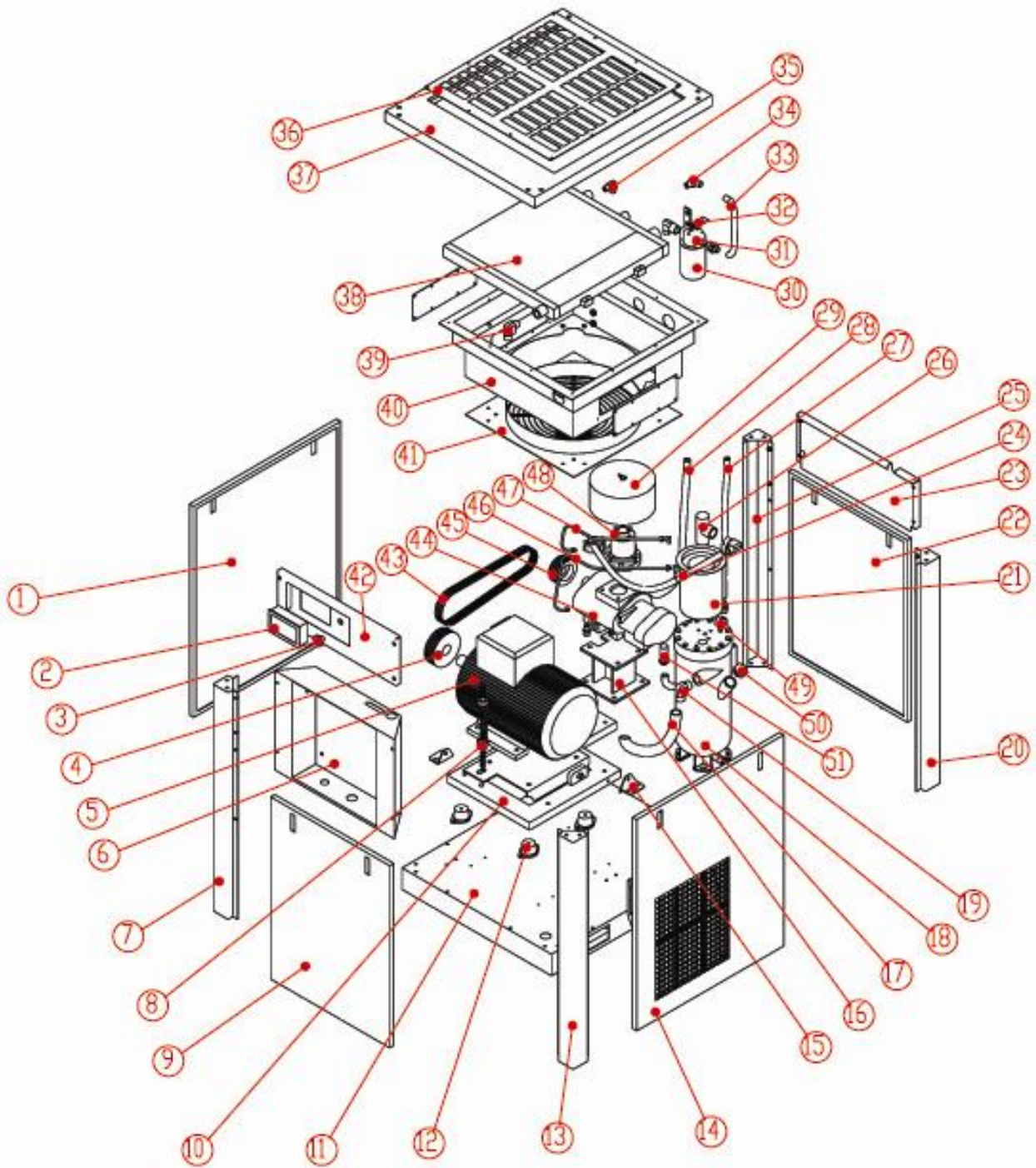

List of Parts of All Cover Conveyor Type Screw Conveyor

S.N.	Name	Quantity	S.N.	Name	Quantity
1	Left shutter	1	27	Oil return pipe of oil and gas barrel	1
2	Digital display panel	1	28	Main return pipe of he head	1
3	Emergency "stop" button	1	29	The air filter assembly	1
4	Motor pulley	1	30	Oil filter	1
5	Motor	1	31	Oil filter joint	1
6	Electric control cabinet	1	32	Oil filter fixed board	1
7	Vertical shaft on left side of the front shutter	1	33	Oil filter exhausting tubing	1
8	Automatic tension spring of the conveyor	1	34	Oil inlet bend	1
9	Front shutter	1	35	Oil return bend	1
10	Anti-vibration platform	1	36	Exhaust shutters	1
11	The main base-plate	1	37	Head cover	1
12	Anti-vibration pad	4	38	Oil-gas cooler	1
13	Vertical shaft on right side of the front shutter	1	39	Exhaust bend	1
14	Shutter on the right side	1	40	The protective cover of the cooler-fan	1
15	Transportation fixed board	1	41	Cooling fan	1
16	Host frame	1	42	Control panel	1
17	Head exhaust pipe of handpiece	1	43	Belt	3
18	Oil-gas barrel	1	44	Handpiece of screw	1
19	Bend	1	45	Headpiece pulley	1
20	Vertical shaft on right side of the back shutter	1	46	A fine differentiating oil return pipe	1
21	Built-in oil-gas fine differentiator	1	47	Unloading pipe	1
22	Back shutter	1	48	Air intake valve	1
23	Deflation opening board	1	49	Oil-gas barrel pressure gauge	1
24	Exhausting pipe of oil and gas barrel	1	50	Refueling plug of Oil-gas barrel	1
25	Vertical shaft on left side of the shutter	1	51	Air intake pipe joints	1
26	Minimum pressure valve	1			

14 Directly-connected type screw machine

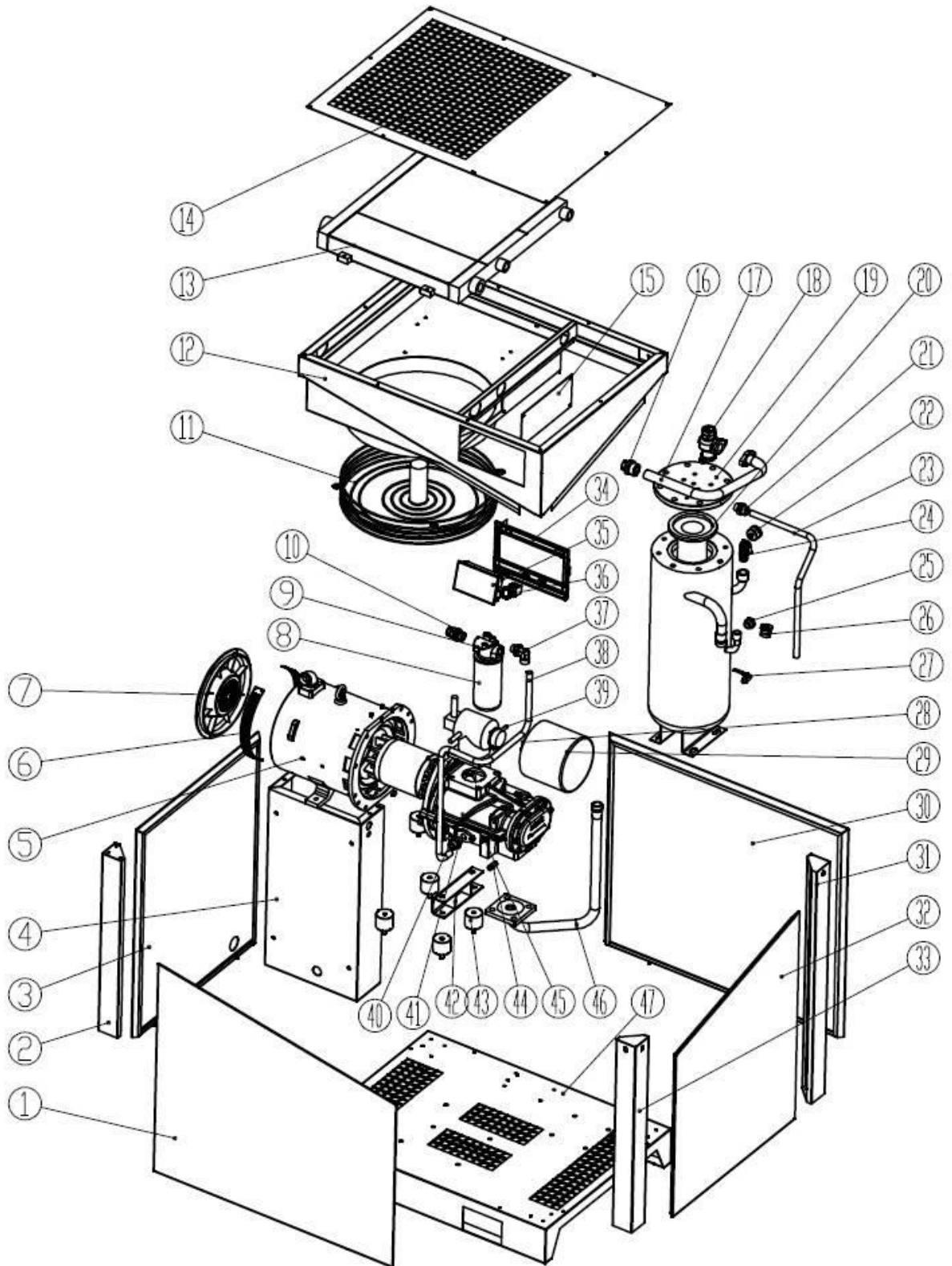

List of the parts of directly-connected type screw machine

S.N.	Name	Quantity	S.N.	Name	Quantity
1	front shutter	1	25	Oil mirror	1
2	Vertical shaft on left side of the front shutter	1	26	Oil inlet plug of Oil-gas barrel	1
3	Left shutter	1	27	Ball valve	1
4	Electric control cabinet	1	28	Air filter element	1
5	Motor barrel	1	29	Air filter cover	1
6	Gridding plate	1	30	Back shutter	1
7	Motor barrel back cover	1	31	Vertical shaft on right side of the back shutter	1
8	Oil filter	1	32	Right shutter	1
9	Oil filter base	1	33	Vertical shaft on right side of the front shutter	1
10	adjustable straight connector	1	34	Plastic panel	1
11	Cooling fan	1	35	Display control panel	1
12	The protective cover of the cooler & fan	1	36	Emergency stop switch	1
13	cooler	1	37	90° adjustable connector	1
14	Head cover plate	1	38	Main return pipe of air end	1
15	Fan cover plate	1	39	Air inlet valve	1
16	Discharge pipe straight connector	1	40	Host machine	1
17	Discharge pipe of oil-gas barrel	1	41	Oil inlet straight connector	1
18	Minimum pressure valve	1	42	Air end support	1
19	Flange cover of oil-gas barrel	1	43	Rubber Anti-vibration foot	1
20	Built-in oil-gas fine differentiator	1	44	oil return valve	1
21	Oil return pipe straight connector	1	45	Temperature sensor	1
22	Pressure gauge	1	46	Discharge pipe of air end	1
23	Oil return pipe of oil and gas barrel	1	47	Main base plate	1
24	Safety valve	1			