

NB00227

**permanent magnet variable frequency screw air compressor**

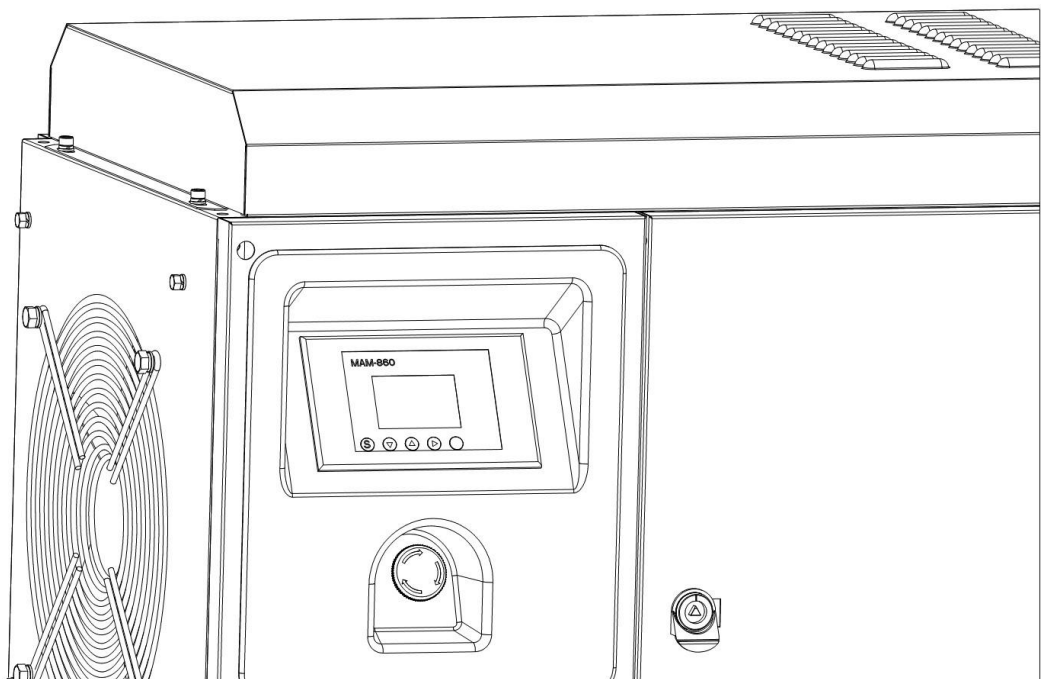

## Thanks

Thank you for choosing our permanent magnet variable frequency screw air compressor; this manual will help you better use the powerful aerodynamic compression system we provide you. We welcome you to give us valuable suggestions or comments at any time.

If you encounter any problems in the process of using our machine, you can get in touch with our customer service technical center in the following ways, and we will solve your problem as soon as possible.

We try our best to ensure the completeness and accuracy of the manual, but we will reserve the right to continuously develop and improve the products and will not be obligated to modify and improve the previous products. When the product design changes, there will be no further notify.

## Foreword

This operation manual describes in detail the safety precautions of the wizard series screw air compressor designed and produced by us, the structure and function of each system and component, and the operation and maintenance methods.

The operator should read this operation manual carefully, and only after fully understanding the structure, function and safety precautions of each system and component of the unit, can the unit be operated and maintained. Except as stated in this book, if the user does not operate and maintain according to the operation and maintenance procedures of this book, or disassemble and modify the machine by himself, or use oil and parts not specified by us, you will Will lose the right to claim.

This operating manual does not provide you with an illustrated catalog of parts. If you need to order parts from our company, please refer to the relevant unit parts manual. What needs to be reminded is that our continues to develop and improve its products. After a certain period of time, the content of the parts manual may differ from the actual situation of the product. Before you order parts, please check with our company's service department.

This operation manual gives a general introduction to the motor and electrical system and maintenance, but before you use and maintain this unit, if you have any questions, please contact your local dealer or our service department.

## Standard guarantee clause

We implements the following guarantees for its manufacturing process and material defects under normal use, maintenance, repair and maintenance of its own screw air compressor products.  
Wizard series screw compressor: 13 months from the date of shipment or 12 months from the trial run, whichever comes first.

Compressor head: in accordance with the head warranty agreement.

Compressor head returned for repair: 6 months from the date of shipment.

Spare parts (except for three filters, oil): 6 months from the date of shipment from the factory or 3 months from the trial run, whichever comes first.

For products not manufactured by us, where feasible, the original manufacturer's warranty terms will be directly quoted. During the warranty period, you must notify our or its authorized agent in writing within 30 days after the defect is discovered, and attach all detailed information for identification, including factory serial number, model, date of purchase, etc.

Our single responsibility under this warranty clause is to repair and replace any product or part that is proved to be defective based on its judgment. If necessary, We may request users to send defective products or parts back to the manufacturer for inspection by way of pre-paid freight.

For repaired products, parts or replacement parts (manufactured by itself), We guarantees a period of 3 months or the remaining warranty period of the repaired product under normal use, maintenance, repair and maintenance.

For the following responsibilities, this guarantee clause does not apply, and we has no responsibilities or obligations

A. Indirect, incidental or special loss or damage.

B. Damage caused by normal wear and tear, abnormal use conditions, negligent or improper use of equipment, improper storage or transportation.

C. Failure to comply with operating instructions, specifications or other special sales conditions.

D. Labor costs, loss or damage caused by improper operation (operation) maintenance, and repairs by non-seller or maintenance personnel authorized by the seller.

E. Unreasonable use of the product.

In any case, the seller's liability for compensation is limited to not exceeding the selling price. Regardless of whether the claim is due to the abolition of the contract or the guarantee of negligence in production.

### NOTICE!

This guarantee clause is the seller's single guarantee clause. Any other guarantee clauses, whether expressly stated or metaphorically stated in law, or metaphorical in fact, including any guarantee clauses for commodity properties and use for a special purpose, are excluded. , Not accepted.

#### *Special reminder for three filter and oil maintenance cycle*

| Serial number | Project                | Time  | Maintenance content  | Remark |
|---------------|------------------------|---|--|--------|
| 1             | Firstguaran<br>tee     | The new machine runs for<br>500 hours or 1 month<br>(whichever comes first) | Change the lubricating oil<br>Replace the oil filter<br>Replace the air filter<br>Replace the oil fine separator |        |
| 2             | Routinemaintenan<br>ce | Run for 2000 hours or half a<br>year (whichever comes<br>first)             | Change the lubricating oil<br>Replace the oil filter<br>Replace the air filter<br>Replace the oil fine separator |        |



★Note: The maintenance period should be shortened appropriately under severe working conditions.

|     |  |      |
|-----|--|------|
| 22  | Chapter 1 Safety Rules.....  |      |
| .26 | Chapter 2 System Function Introduction.....  |      |
|     |  | . 28 |
|     | 2.1 Introduction.....  | 28   |
|     | 2.2 Compressor head and compression cycle.....   | 28   |
|     | 2.3 Electrical control.....  | 31   |
|     | 2.4 Controller and function parameter table.....   | 32   |
|     | Chapter 3 Installation and Acceptance.....   |      |
|     |  | 35   |
|     | 3.1 Installation, acceptance and storage:.....   | 35   |
|     | 3.2 Installation and positioning.....  | 35   |
|     | 3.3 Storage and maintenance of the whole machine.....  | 36   |
|     | 3.4 Installation, piping and electrical wiring.....  | 36   |
|     | 3.5 Precautions for piping, foundation and cooling system.....                                   | 36   |
|     | 3.6 Installation of safety facilities.....   | 37   |
|     | 3.7 Electrical installation.....   | 38   |
|     | 3.8 Wiring diagram (open the inverter cover):.....   | 39   |
|     | Chapter 4 Operating Rules.....   |      |
|     |  | 40   |
|     | 4.1 Overview.....  | 40   |
|     | 4.2 Ready to start.....  | 40   |
|     | 4.3 Routine start-up steps.....  | 40   |
|     | 4.4 Shutdown procedure.....  | 41   |
|     | Chapter 5 Maintenance.....   |      |
|     |  | 42   |
|     | 5.1 Preparation before maintenance.....  | 42   |
|     | 5.2 Maintenance of screw compressor.....   | 42   |
|     | 5.3 Maintenance tips and update setting method after maintenance:.....                           | 43   |
|     | 5.4 Gas storage tanks need to be drained regularly.....  | 43   |
|     | 5.5 Maintenance plan.....  | 44   |
|     | 5.6 Common troubleshooting table (Power and gas must be cut off during manual inspection ) ..... | 45   |
|     | 5.7 Schematic diagram of screw fitting explosion.....  | 47   |
|     | Reference circuit wiring diagram.....  | 48   |

# Chapter 1 Safety Rules

## Safety warning signs

In this manual, the operations and matters involving safety are defined and classified according to the severity of damage to the machine and the degree of personal injury that the operation may cause, and the following signs are used to express and explain in bold.

|   |   |
|---|---|
|    | "Warning" means that you must confirm that it is properly grounded before starting the machine.   |
|    | "Caution" indicates unsafe factors that may cause general damage to the machine or personal injury.   |
|    | "Warning" indicates unsafe factors that may cause property damage or personal injury.   |
|    | "Warning" means electrical equipment, and only qualified personnel can operate in accordance with the specifications.   |
|    | "Warning" means that the unit will restart automatically, which may cause serious injury to the human body and equipment.   |
|   | "Warning" means do not touch the surface of hot objects. To prevent burns, please do not approach this surface.   |
|  | "Warning" means that moving parts can cause serious injury to the body. Do not operate the equipment without a protective cover or when the protective cover is damaged.  |
|  | "Danger" refers to unsafe factors that can cause major accidents or personal injury.  |
|  | "Danger" means an unsafe factor that can cause serious personal injury or death with a voltage exceeding the safety level. All electrical work must be done by a qualified electrician.                             |
|  | "Dangerous" means that it is used for breathing and food handling. The compressed air must comply with the standards OSHA 29CFR1910.134 and FDA 21CFR178.3570, otherwise it will cause human injury and even death. |
|  | "Dangerous" means that the pressurized gas will cause serious damage to the human body, equipment and property, or even death.  |
|  | "Caution" means unsafe factors that may cause property damage or personal injury to hot surfaces.   |
|  | "Attention" indicates important installation, operation and maintenance information.  |

## Safety warning

Be sure to read carefully before operating and using the compressor



Compressed air and compressed air systems are dangerous!

Failure to comply with the operating procedures and safety precautions of this operating manual may cause accidents and cause the possibility of injury or death to yourself or other personnel!

Before operating and maintaining the compressor, you must carefully read and understand this operation manual!

Before the machine leaves the factory, obvious warning decals have been affixed to dangerous places and places that require attention.

Before performing any operation and maintenance on the unit, you must read and understand this operation manual.

1. The unit must not be operated at an exhaust pressure higher than the rated exhaust pressure of the unit, otherwise the motor will be damaged due to overload.

2. When the unit leaves the factory, various protection controls are set up intact, and the control components of the unit must not be changed or dismantled at will, otherwise it will cause serious equipment and personal injury accidents

3. When the unit is running, never disassemble or loosen any pipeline components, joints, plugs and couplings, and do not pull the safety valve. The unit is full of hot working fluids under pressure, which can cause serious personal injury accidents.

4. Before performing any maintenance work on the unit, you must confirm:

The unit has stopped;

The internal pressure of the unit has been completely vented;

The power is turned off.

5. Only safe solution can be used to clean the compressor and auxiliary equipment of the unit.

6. Once any part fails, it must be replaced immediately, otherwise it may cause immeasurable losses.

7. This machine is for indoor use and cannot be used in the open air. Must be grounded ★★★

The safety measures and safety precautions listed below are only part of the matters that must be observed when using the compressor and compressed air system, but not all of them.



Failure to observe the following safety measures will result in personal injury or death, property damage or compressor damage.

Only trained and authorized persons can operate the compressor. Before any work, you should read this operation manual carefully and fully understand its contents. Failure to follow the operation and maintenance procedures and safety rules in the operation manual may cause accidents and personal injury.

Never start the unit under unsafe conditions; if there is a problem with the unit, do not try to start it. The power supply should be cut off and an obvious sign should be made to prevent unknowing people from misoperation.

Compressed air is dangerous, and the unit can be repaired and maintained only when the compressed air in the entire compressor system has been emptied.

Do not change the internal structure and control method of the unit unless it is approved in writing by us si Keluo Company.

If it is a unit with movable wheels, please make sure that the wheels have been secured by effective measures before starting the machine.

Do daily maintenance and maintenance. The unit should be carefully checked every day to see if there is any leakage, loose parts, damage, adjustment failure or missing parts, etc., and deal with problems in time.

## Chapter 2 System Function Introduction

### 2.1 Introduction

The Elf series permanent magnet inverter compressor designed and manufactured by us is a positive displacement, oil-injected twin-screw compressor. The motor and the male rotor of the compressor head are integrated to drive the compressor to rotate. The unit has good power, economy and reliability.

This unit has reasonable layout, complete functions, simple operation and maintenance, and beautiful appearance. All instruments, indicators and control devices are concentrated on the control panel, which is easy to operate and can run stably and reliably for a long time, see Figure 2-1. In order to keep the screw compressor unit you have purchased or used in the best operating condition, please read Chapter 5 Maintenance in this operation manual carefully.

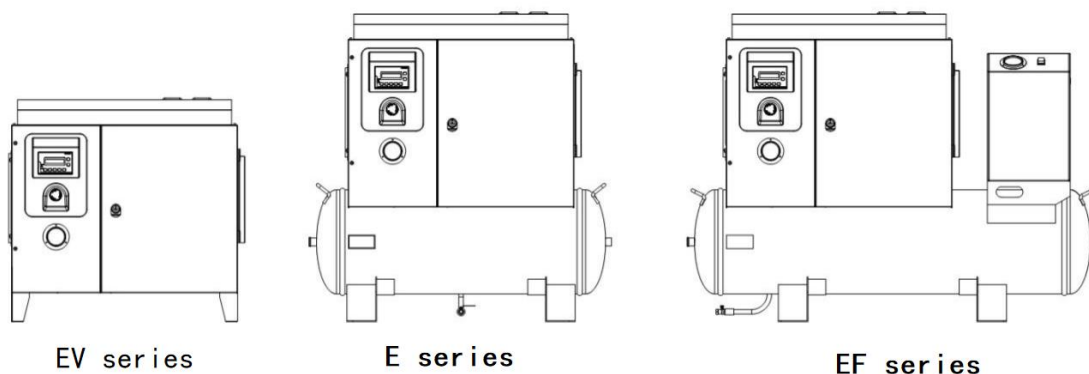
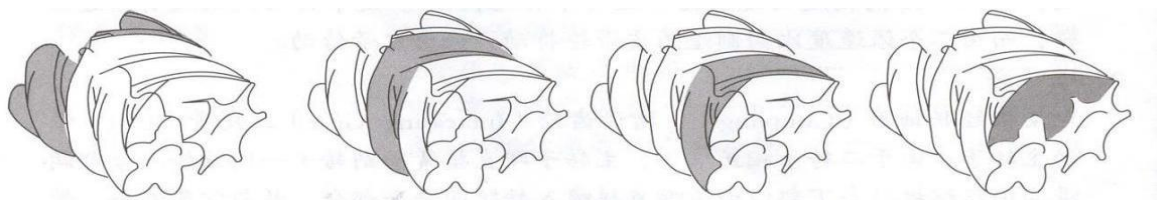

diagram 2-1

### 2.2 Compressor head and compression cycle

Compressor head (host). Refer to Figure 2-2. When working, air enters the casing through the air inlet at the power input end. When the rotor turns over the edge of the suction orifice on the casing, a part of the sucked air is enclosed in the female and male rotors and in the enclosed volume of the screw groove formed by the casing, the enclosed volume of the screw groove changes continuously with the meshing movement of the female and male rotors, so as to realize a continuous working cycle of suction, sealing, compression, and exhaust. The compressed air passes through the exhaust port. Exhaust into the oil and gas barrel.



1. Inhalation process
2. Closed and conveyed
3. Compression and fuel injection stroke
4. Exhaust process

Figure 2-2 Compression cycle

#### 2.2.1 Air intake system

Refer to Figure 2-3. The function of the air intake system of the compressor unit is to provide clean air to the compressor. It includes an air filter and an air intake valve.



Figure 2-3 Air intake system

### 2.2.2 Compressor exhaust system

The exhaust system of the compressor unit is mainly composed of oil and gas barrels, gas storage tanks, combination valves, oil separators, safety valves, etc.

The oil and gas barrel part can realize the phase separation of the mixture of oil and gas. An oil fine separator is installed above the oil and gas barrel. The compressed air after the oil and gas separation contains only a few PPM (usually below 3PPM) of lubricating oil. On the left side of the tank is the gas storage tank, which acts as a buffer and has a good protective effect on the air compressor. It can filter out part of the condensed water, and it also has the function of reducing the gas exhaust temperature, which can reduce the dryer load.

The gas storage tank is located under the machine to store gas.

The combined valve integrates the oil fine separator seat, the oil filter seat, the pressure maintaining valve, and the safety valve interface. The function of the pressure maintenance valve is to ensure that the compressor establishes a minimum tank pressure in the system during normal operation to ensure the normal operation of the lubricating oil circuit. When the unit is shut down, the pressure maintaining valve is a check valve to prevent the compressed air from returning. The opening pressure of the pressure maintenance valve is  $4.0 \pm 0.34 \text{ bar}$  ( $60 \pm 5 \text{ psi}$ ), which has been preset before leaving the factory.

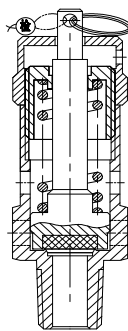

Figure 2-5 Safety valve

There is a safety valve for the oil and gas barrel and the gas storage tank on the barrel. When the gas pressure in the tank exceeds the set pressure of the safety valve, the safety valve will open automatically. The opening pressure of the safety valve has been set before leaving the factory, please do not change it without authorization.



warn

- When the compressor is running or under pressure, do not disassemble nuts, oil plugs and other parts. Shut down and release all internal pressure before maintenance operations.
- It is not allowed to replace and use other types of safety valves.



### 2.2.3 Compressor cooling and lubrication system

The compressor cooling and lubrication system consists of an oil and gas barrel, an oil cooler, a combination valve, an oil filter and an oil pipeline, etc.

The oil filter consists of a filter seat and a replaceable spin-on filter element with a built-in bypass valve. When the filter element is dirty or the oil viscosity is too high, it can ensure the smooth flow of the oil path and the normal operation of the compressor.

Oil cooler: The cooler is an aluminum plate-fin structure. The cooling fan forces air to flow through the cooler fins to cool the lubricating oil in the cooler pipe. In daily maintenance, the surface of the cooler should be cleaned regularly, and if necessary, it can be flushed with high-temperature pressure water not greater than 3.5Bar.

### 2.2.4 Compressor air volume adjustment and control system

The Genie series compressor unit is equipped with a standard automatic control system.

After the machine is turned on, it runs at no-load and enters the loading state after 10 seconds. The motor frequency is adjusted according to the pressure of the back-end pipe network. When the system reaches the unloading stop pressure, the solenoid valve closes the intake valve, the compressed air in the oil-air separator is emptied, and the screw compressor runs without load for 600 seconds (set value). If there is no use of air, the air compressor enters a sleep state. After the pressure is lower than the set value, the screw compressor restarts and runs reciprocatingly so that the user's air pressure is not lower than the set value.

The air volume adjustment and control system of the compressor unit is mainly composed of the following components:

Intake control valve, pressure regulating valve, discharge valve, orifice, and pipe fittings and joints connecting various components.

The operation of the machine mainly has three states: A. Start load operation condition; B. Stop condition; C standby state.

Under normal circumstances, the air volume adjustment and control system of the compressor unit has been set at the factory, and the user does not need to make adjustments. If you really need to adjust, you should refer to the controller instruction manual.

The unit adopts the air volume adjustment method of air intake throttling, that is, by controlling the opening of the intake valve to control the air volume of the compressor, so as to achieve the purpose of air volume adjustment. The unit has four working conditions: A. Starting conditions; B. Load operating conditions; C. Frequency conversion regulating operating conditions; D. Standby conditions. The following takes a model with a rated pressure of 8 bar (116 psi) as an example to introduce its working principle, and the work of units with other rated pressures can be deduced by analogy.



Do not think that the compressor is not running and it is safe to perform maintenance operations on it. The compressor may be in a "waiting" state and may start at any time. Please strictly follow all relevant regulations in the "Repair and Maintenance Regulations".

### 2.3 Electrical control

#### 2.3.1 Electrical schematic diagram (single-phase -220V)

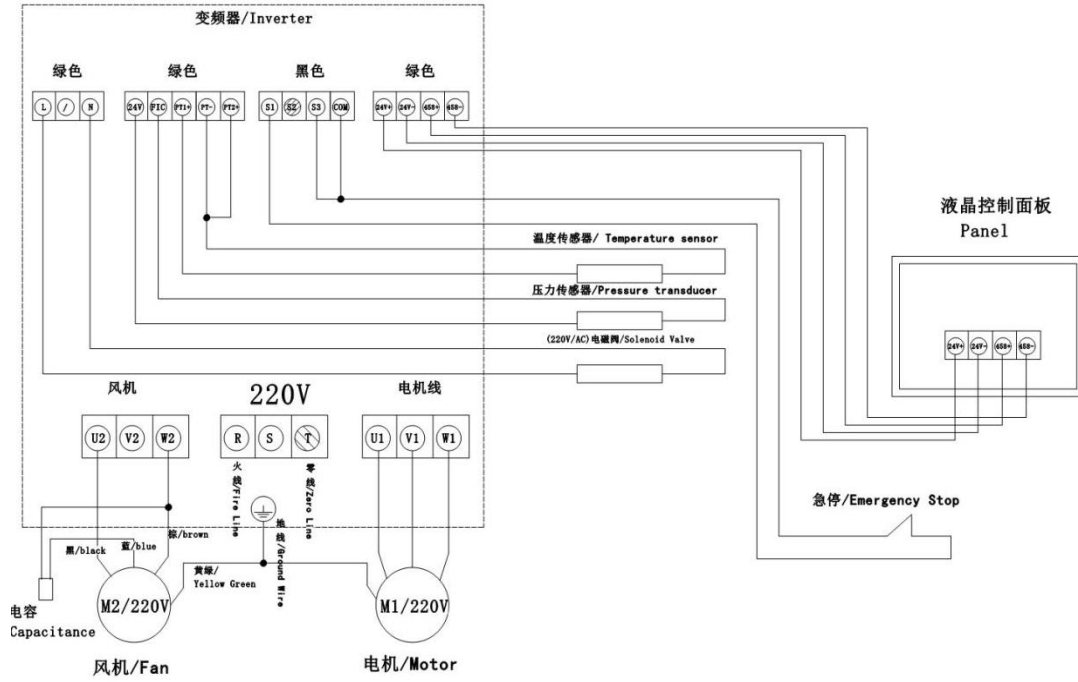

#### 2.3.2 Wiring intention of inverter users

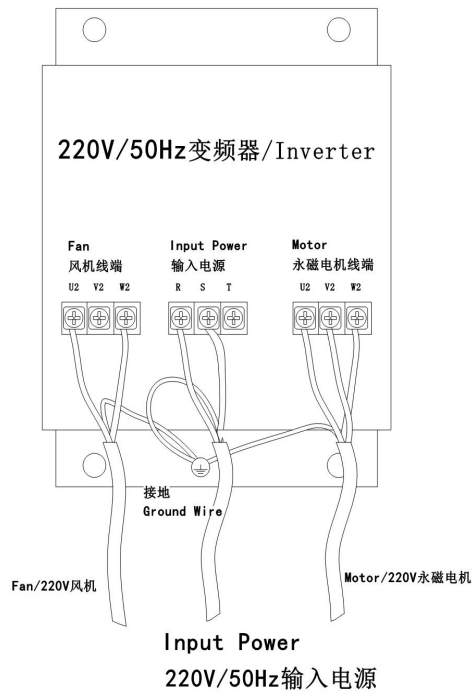

## 2.4 Controller and function parameter table

### 2.4.1 Controller key description

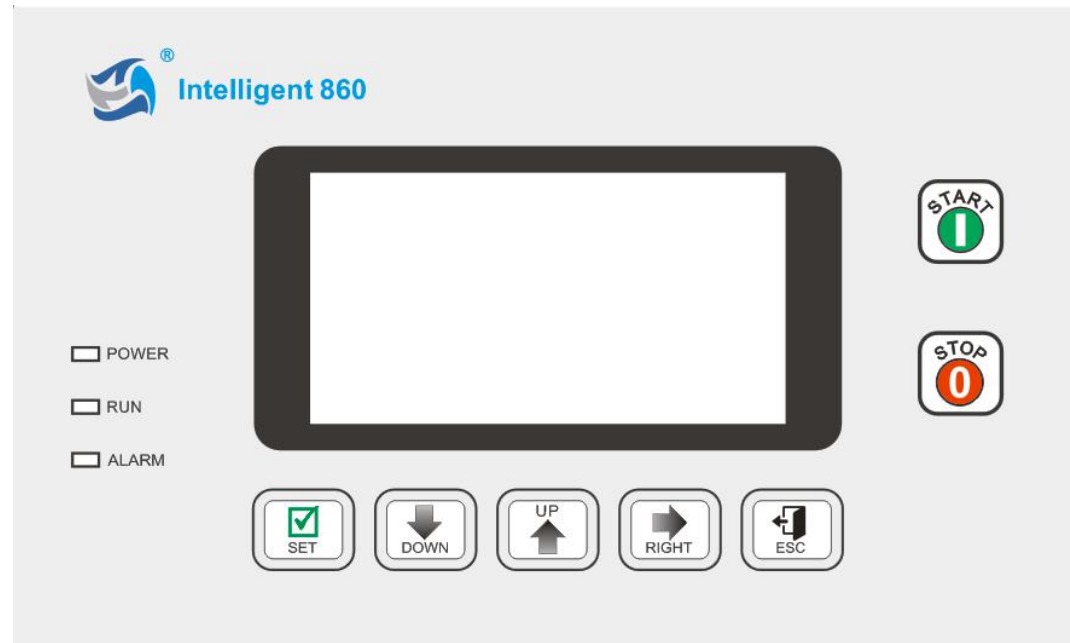

—Start button:

1. When the air compressor is in standby mode, press this button to start the air compressor;



—Stop button/Reset button:

1. When the air compressor is running, press this button to stop the air compressor;
2. When the fault stops, press this button to reset the fault



—Add/Unload button/Confirm button:

1. When the air compressor is running, this key is used as the add and unload key.
2. In the setting mode, press this key to confirm and save the input data;

—Down key/Decrease key:



1. When viewing the parameters, press this key to move the scroll bar down;
2. When modifying data, press this key to decrement the current flashing position data.



—Up key/Increment key:

1. When viewing the parameters, press this button to move the scroll bar up;
2. When modifying data, press this key to increase the current position data.



—Shift key/Enter key:

1. When modifying data, press the key as the shift key to move the cursor to the next data bit;
2. Press this key during menu selection to enter the next menu of the current menu.



—Return button/Reset button:

1. In the setting mode, press this key to exit the setting mode,
2. In the parameter view mode, press this key to return to the previous menu;

#### 2.4.2 Indicator light description

Power supply: The indicator light is on after the controller is powered on.

Running: When the air compressor motor is running, the running indicator light is on.

Fault: When fault occurs, the fault light is always on;

#### 2.4.3 User parameter table and functions

| A menu                          | Secondary menu        | Set initial value | function  |
|---------------------------------|-----------------------|-------------------|---|
| Pressure and temperature preset | Preset pressure       | 00.70MPa          | The target force set during inverter control.   |
|                                 | Loading pressure      | 00.60MPa          | 1, Automatic loading mode, the controller automatically loads when the pressure is lower than this value<br>In standby mode, the pressure is lower than this value, and the operating conditions are met, the controller automatically starts |
|                                 | Unloading pressure    | 00.80MPa          | 1. If the pressure is higher than this value, the controller will automatically unload<br>2. This value should be less than or equal to "unloading high limit"  |
|                                 | Fan start temperature | 0080 °C           | When the exhaust temperature is higher than the value set here, the fan runs.   |
|                                 | Fan stop temperature  | 0070 °C           | When the exhaust temperature is lower than the value set here, the fan stops.   |
| Start-stop delay preset         | Start delay           | 0010 s            | Motor delay time  |
|                                 | Loading delay         | 0002 s            | After corner operation, delay loading time (applicable to power frequency control)  |
|                                 | Unloading delay       | 0600 s            | The longest continuous no-load operation time allowed by the air compressor exceeds<br>Stop automatically after this time.  |
|                                 | Stop delay            | 0010 s            | After the air compressor receives the stop command, it turns to no-load operation.<br>After the load operation exceeds the time set here, it will automatically stop.   |
|                                 | Restart delay         | 0100 s            | After a normal shutdown, an empty vehicle shutdown for a long time, or a fault shutdown, the air compressor can be restarted after delaying the time set here.  |
|                                 | Oil filter used       | 0000 hours        | The accumulated used time of the oil filter. After replacing the new oil  |

|                             |                      |            |   |
|-----------------------------|----------------------|------------|---|
| Maintenance parameter reset |                      |            | filter,Manually clear.  |
|                             | Oil separator used   | 0000 hours | The accumulated used time of the oil separator. After replacing the new oil separator,Manually clear.   |
|                             | Air filter used      | 0000 hours | The air filter has accumulated used time. After replacing the new air filter,Manually clear.  |
|                             | Lubricant used       | 0000 hours | The accumulated used time of lubricating oil, after replacing lubricating oil,Manually clear.   |
|                             | Grease used          | 0000 hours | The accumulated used time of the grease. After the grease is replaced, theManually clear.   |
| Maximum use time preset     | Oil filter preset    | 500 hours  | 1. When the accumulative use time of the oil filter exceeds the value set here, the controller will warn;<br>2. When set to "0000", the oil filter warning function is prohibited       |
|                             | Oil separator preset | 500 hours  | 1. When the accumulative use time of the oil separator exceeds the value set here, the controller will warn;<br>2. When set to "0000", the oil separator warning function is prohibited |
|                             | Air filter preset    | 500 hours  | 1. When the cumulative use time of the air filter exceeds the value set here, the controller will warn;<br>2. When set to "0000", the air filter warning function is prohibited         |
|                             | Lubricant preset     | 500 hours  | 1.When the cumulative use time of lubricating oil exceeds the value set here, the controller will warn;<br>2. When set to "0000", the lubricating oil warning function is prohibited    |
|                             | Grease preset        | 500 hours  | 1.When the accumulative use time of grease exceeds the value set here, the controller will warn;<br>2. When set to "0000", the lubricating oil warning function is prohibited           |
| user password               | ****                 | ****       | Modifiable user password; can use old user password or factory Home password reset  |

#### 2.4.4 Adjust parameters

The adjustment parameters are used to set the relevant data of the controller and are not allowed to be viewed and modified by users who are not authorized by the manufacturer. The user needs to verify the adjustment password before viewing the adjustment parameters.

## Chapter 3 Installation and Acceptance

### 3.1 Installation, acceptance and storage:

The machine is transported from the factory to the site to be installed in place. The shutdown maintenance and correct maintenance are related to the integrity and normal use of the equipment. Therefore, after receiving the machine, you should immediately check whether there is any damage caused by transportation. If damage is found, the carrier can be asked to sign the shipping documents and make a damage report. If you did not find it in time at that time, but found concealed damage afterwards, please inform the carrier within 15 days after receiving the goods, and ask the carrier to make a damage report. A detailed report is very important for the handling of losses (claims).

Check the nameplate of the compressor to determine whether the machine is the model and specification you have ordered, and whether the options are included. At the same time, check the oil and gas barrel and safety valve to confirm whether the design or set pressure is correct. For the unit that is temporarily not installed or will not operate for a long time, a protection and maintenance plan must be set to ensure the normal operation of the unit, especially the main engine head.

### 3.2 Installation and positioning

This series of compressor units are used in indoor environments. The compressor should be placed in a clean and well-ventilated environment. The foundation should be firm. For safety and ease of maintenance and daily inspections, there must be enough space around the machine (in the vicinity of the compressor and Reserve at least 1.2 meters of space at the top, see Figure 3-2).

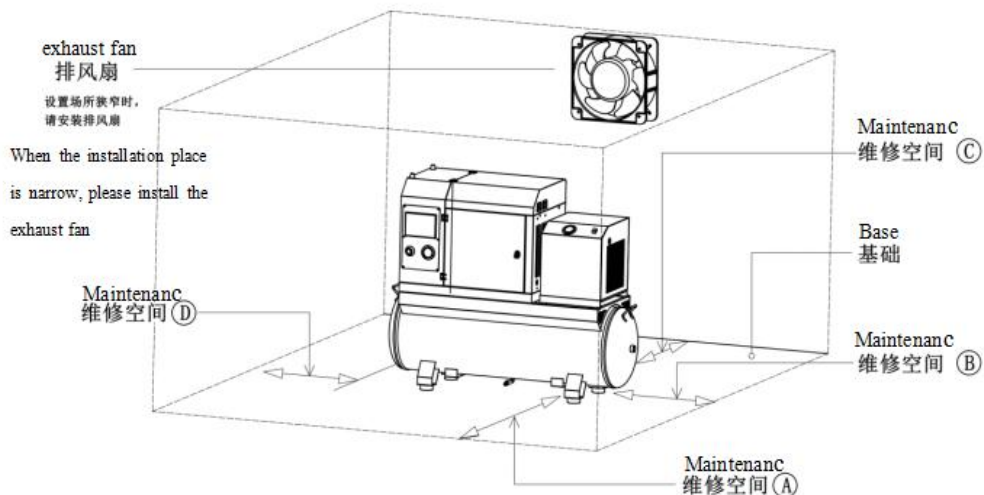
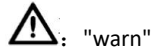

Figure 3-2 Installation space

The ambient temperature of the compressor should not exceed 40°C (104°F). Prevent the hot air discharged by the cooling fan from circulating in the machine room and causing the ambient temperature to rise. In principle, all the fixed screw compressors of us are for indoor installation. After modification, they can also be installed outdoors in some places. Rain, snow and freezing should be avoided.



: "warn"

The compressor cannot work in an environment below 0°C (32°F) or above the upper limit of the maximum operating temperature.



: "Notice"

The compressor needs enough clean air for normal operation



: "Notice"

Removal or modification of the soundproof cover will generate high noise and endanger human health.



: "warn"

Do not install or expose the compressor to toxic, volatile, or corrosive gas, and do not store substances of similar nature near it, otherwise it will cause serious casualties and property losses.

For the design, installation and use of the compressor room, please refer to GBJ29-90 "Code for Design of Compressed Air Station".

### 3.3 Storage and maintenance of the whole machine

When the unit is placed for a long time or stops operating for a long time, you must first ensure that the installation environment is clean and dry. Check the main components and joints of the unit, clean to ensure that there is no leakage or rust, and run for at least 60 minutes every month to ensure the safe lubrication of the main unit head; secondly, check carefully before starting up, and replace the unit if necessary Lubricating oil, perform a 2-hour full-load operation test on the unit, record the data, and ask a qualified professional service engineer for guidance.

### 3.4 Installation, piping and electrical wiring

In any case, the pipe size should not be smaller than the connecting size of the compressor discharge pipe.

For the compressor, the air filter is indispensable, and the air source that can provide clean air should be selected.

### 3.5 Precautions for piping, foundation and cooling system

#### 3.5.1 Precautions for air pipe piping

- 1) When piping the pipeline, the pipeline must have an inclination of 1-2 degrees to facilitate the drainage of condensed water in the pipeline.
- 2) The pressure drop of the piping should not exceed 5% of the set pressure of the air compressor, and it is better to choose a larger pipe diameter than the design value.
- 3) The branch pipeline must be connected from the top of the main pipeline to prevent the condensed water in the pipeline from flowing into the working machine or returning to the air compressor.
- 4) Do not reduce the main pipeline arbitrarily. If necessary, reduce or enlarge the pipeline, use a reducer. When the gas flows in the pipe, frictional resistance is generated in the straight pipe section: local resistance is generated at the valve, tee, elbow, reducer, etc., which leads to gas pressure loss. The pressure drop within a length of pipeline can be checked from Table 3-1:

Table 3-1: Flow rate-piping pressure drop Kg/cm<sup>2</sup>-(100m)

| Flow<br>m <sup>3</sup> /min | Diameter (mm) |      |       |        |       |        |
|-----------------------------|---------------|------|-------|--------|-------|--------|
|                             | DN15          | DN20 | DN25  | DN32   | DN40  | DN50   |
| 0.8                         | 5.87          | 1.23 | 0.339 | 0.0858 | 0.038 |        |
| 1.0                         | 9.18          | 1.92 | 0.53  | 0.134  | 0.059 | 0.0157 |

instruction:

1. The actual pressure drop of straight pipe section = table value x pipe length/(100 x compression ratio).  
(Compression ratio=gauge pressure+1)
2. Part of the pressure drop in the pipeline should also be added to the partial pressure loss produced by elbows, reducers, tee joints, valves, etc. These values can be checked from the relevant manuals.
3. For the selection of air compressor post-processing equipment (cold dryer, suction dryer, filter), see Table 3-2. Precision filter, C series centrifugal oil-water separator, T series main line filter, A series micro oil mist filter. H series of active adsorption filters are mainly used in food, medicine and pharmaceutical factories.
4. For compressed air with system pressure below 1.5MPa, the flow velocity in the delivery pipe must be below 15m/sec to avoid excessive pressure drop.
5. Minimize the use of elbows and various valves in the pipeline to reduce pressure loss.

### 3.5.2 Precautions for air compressor room ventilation

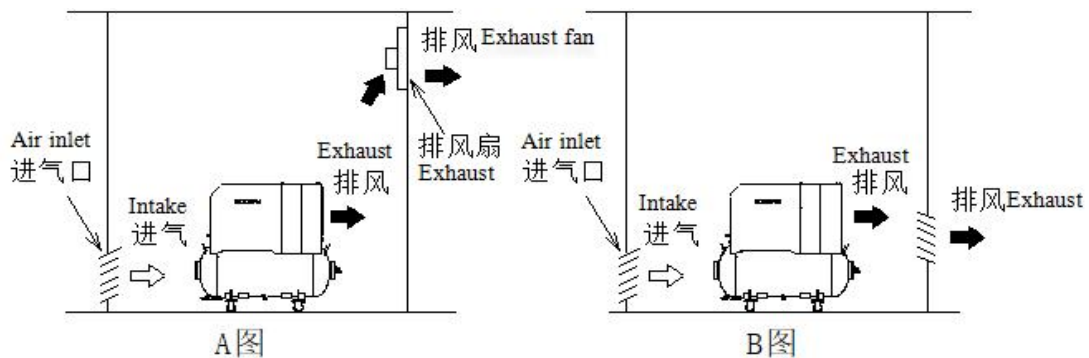

Figure 3-3 Indoor ventilation

When the compressor room is narrow, please install an exhaust fan higher than the side wall of the compressor exhaust port, and set the air intake port at a low place on the intake side wall (see Figure 3-3 A). When the compressor is installed in a spacious workshop, please choose a well-ventilated location for installation (see Figure 3-3 B).

## 3.6 Installation of safety facilities

### 3.6.1 Safety valve (pressure relief valve)

The safety valve is a pressure relief device used to protect the system. It has been set at the factory. You cannot change its pressure setting or block this valve at will. Only safety valve manufacturers or qualified agents can carry out this work. The gas discharged from the safety valve should be led to a safe place away from the crowd.



It is not allowed to change, weld, repair or reprocess GB (or ASME) pressure vessels, and it is not allowed to use them under conditions exceeding the rating of the nameplate, otherwise it will affect the insurance clauses and cause serious personal injuries and property losses.

### 3.6.2 Protective cover

All mechanical movements have different degrees of danger, so a protective cover should be provided. This series of units is fully equipped with necessary protective facilities in accordance with national and industry



standards. Users should check and maintain them regularly, and cannot be changed or dismantled at will.

### 3.6.3 Manual vent valve and shut-off valve

It is recommended to install a manual vent valve in the customer's air system. The purpose of installing the manual vent valve is to discharge the air in the compressor and its exhaust pipe to the atmosphere. When the system gas tank is only used with a single compressor, the vent valve can be installed on the gas tank. If a shut-off valve is installed in the system, the manual vent valve should be installed upstream of the shut-off valve. This configuration ensures maintenance and Personnel and equipment are in a safe state during maintenance.

If it is only to isolate the compressor from the system for maintenance, please be careful not to replace the stop valve with a check valve.

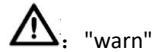

The manual vent valve must be opened before servicing the machine to vent the pressure in the compressor and the system. Negligence in reducing the pressure of the system may cause serious personal injury, death and property damage.

## 3.7 Electrical installation

Before installation, check whether the power supply, power cord, and transformer capacity are consistent. Appropriate fuses or circuit breakers should be equipped during installation. The unbalance between voltage phases must be limited to less than 5% to prevent overcurrent caused by low voltage. User power cord and air switch selection, see Table 3-3 for details, user air switch current specifications are selected at 1.5-2 times the total current. The compressor must be well grounded, see electrical wiring diagram.

**Table 3-3: User power cord and air switch selection**

| Model (HP)  | Rated power (kW) | Line current (A) | Calculation of current-carrying capacity of customer power cord diameter at 40°C | User air switch specifications are not less than the following current (A) |
|-------------|------------------|------------------|--|--|
| CCS3-1x230  | 2.2              | 10               | 2.5mm <sup>2</sup>   | 16   |
| CCS6-3x230  | 4.4              | 13.5             | 2.5mm <sup>2</sup>   | 16   |
| CCS10-3x230 | 7.5              | 20               | 6 mm <sup>2</sup>  | 32   |
|             |                  |                  |  |  |

Note: 1. For C5E/single-phase models, it is recommended to use a power cord with a wire diameter of not less than 3\*2.5 mm<sup>2</sup>.

2. If the power distribution cabinet is far away from the air compressor, the wire diameter needs to be increased accordingly to prevent excessive voltage drop from affecting the operation of the machine.

Power inlet wiring

3.8 Wiring diagram (open the inverter cover):

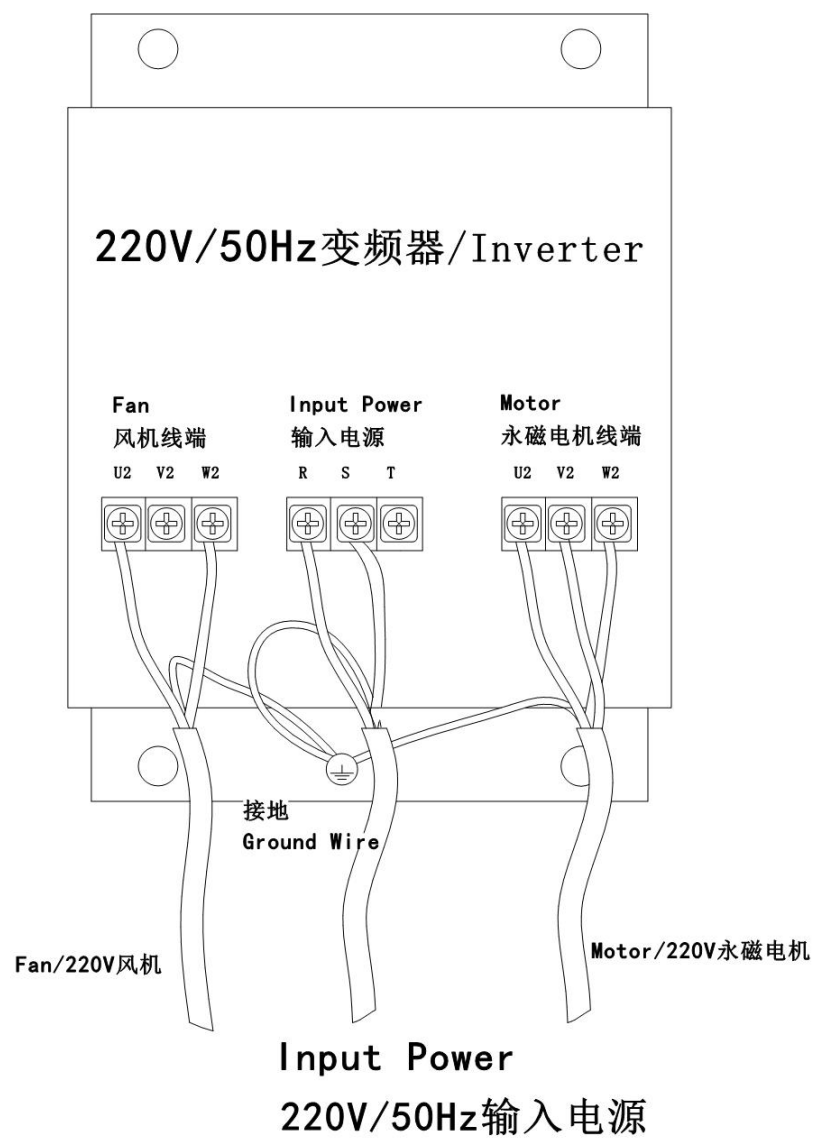

## Chapter 4 Operating Rules

### 4.1 Overview

This series of screw compressor units are equipped with a series of control elements and display/indicating elements. In order to ensure the normal operation of the unit, the operator needs to be able to operate the machine correctly, and it is also required that the operator can make correct judgments on the operating status or fault conditions of the unit based on the displayed/indicated values or conditions. Before starting the unit, the operator should be familiar with the position, function and usage of the control/control elements and display/indication elements. Refer to the controller manual for details.

### 4.2 Ready to start

- 1) Remove the debris and tools around the compressor.
- 2) Remove the bolts or devices for transportation and fixation.
- 3) Check the oil level to make sure it is in the normal position (see Lubricants section).
- 4) Check the fan to make sure it is installed firmly.
- 5) Check whether all pressure pipe joints are firm and not loose.
- 6) Open the air supply valve.
- 7) Check and make sure that the safety valve is installed in place.
- 8) Check whether all cover plates and protective devices are safe and firm.
- 9) Check whether the current setting of the fuse, circuit breaker or controller is suitable and whether the setting is correct.
- 10) Check whether the air filter is installed reliably.
- 11) Turn on the power switch, the screen light is on. Jog the start button to ensure that the compressor steering is consistent with the prescribed steering.
- 12) Please turn on the switch of the cooling and drying machine (C5F)

### 4.3 Routine start-up steps

- 1) Open the shut-off valve leading to the air supply system.
- 2) Press the start button after presetting the control parameters.
- 3) Observe whether the compressor has abnormal vibration, noise, or gas/oil leakage after starting. If any problem is found, please stop it immediately and make corrections.
- 4) Close all the soundproof cover doors to control the noise of the unit and ensure the normal flow of cooling air.
- 5) Slowly close the air supply shut-off valve and check whether the unit is unloaded according to the setting. Refer to Chapter 6 Working Condition Parameter Setting and Adjustment.
- 6) Check whether the indicated value of each status parameter is normal.
- 7) Please carefully observe the operation of the compressor during the first hour of operation, and observe it at any time for the next seven hours. If there is any abnormality, please shut down for maintenance.
- 8) After the initial operation, shut down according to the shutdown procedure, and check whether the oil tank

needs to be filled with lubricating oil; check whether the connections are loose.  "Notice":

① Drain the condensed water at the bottom of the oil and gas barrel regularly. The operation of discharging condensate should be carried out before starting the unit.

② Drain the condensate at the bottom of the control line filter regularly (weekly). The operation of discharging condensate should be carried out before starting the unit

#### 4.4 Shutdown procedure

4.4.1 Press the stop button.

4.4.2 Close the shut-off valve leading to the air supply system.

4.4.3 Turn off the power switch.



"Caution": Closing the shut-off valve during shutdown can prevent the compressed air of the air supply system from flowing back to the compressor due to the damage of the check valve, causing leakage and damage to the mechanical parts.

1. Emergency stop: In abnormal conditions, press the emergency stop/reset switch to stop, and cut off the power switch.

## Chapter 5 Maintenance

### 5.1 Preparation before maintenance

In order to ensure the normal operation and long service life of the unit, good maintenance is the key. Therefore, the maintenance procedures for screw compressor units must be carefully implemented. Before proceeding with maintenance, please read carefully the safety rules in Chapter 1 of this manual, and make at least the following preparations:

- 1) Cut off the power of the host and hang a sign on the power switch.
- 2) Close the shut-off valve leading to the air supply system to prevent the compressed air from flowing back to the repaired part.
- 3) Open the manual vent valve to vent the pressure in the system and keep the vent valve in an open state.
- 4) Ensure that the compressor unit is cooled to prevent scalds and burns.
- 5) Wipe off oil and water marks on the ground to prevent slippage.



"warn"

- Don't think that the machine is shut down, just think that it can be overhauled and maintenance work, the automatic control system of the machine will start the compressor at any time.
- Poor maintenance not only affects the normal operation of the unit, but may also affect the safety of operators.
- When the compressor is running or under pressure, do not disassemble nuts, filler plugs and other parts.
- Do not use flammable solvents such as gasoline or kerosene to clean the air filter or other parts. Safe solvents should be used according to the instructions.

### 5.2 Maintenance of screw compressor



"Attention": Only trained and qualified maintenance personnel are qualified to perform maintenance on the machine.

#### 5.2.1 Replacement of air filter

element:

1. Unscrew the dovetail screw on the top of the air filter housing



1. Unscrew the dovetail screw on the top of the air filter housing



### 5.2.2 Cooling oil replacement:

1. Prepare the container, remove the oil drain plug and release the old cooling oil

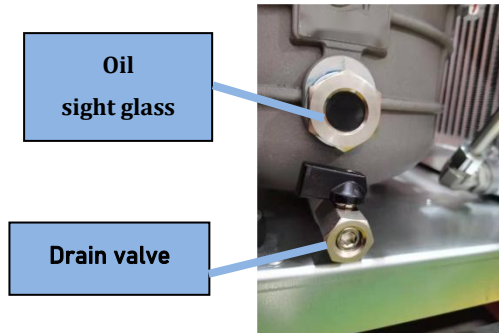

2. Open the refueling plug and add special cooling oil, Recover the plug after reaching the 2/3 to 3/4 position of the oil sight glass

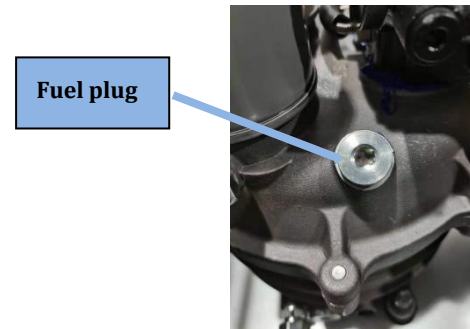

### 5.2.3 Replacement of oil filter and oil-air separator:

1. Use a belt wrench or special wrench to remove the old product

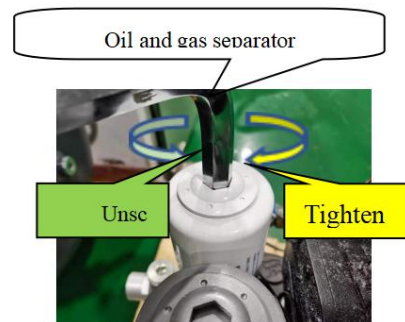
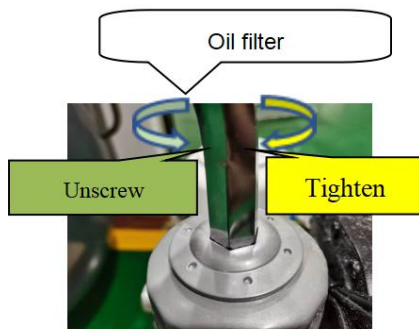

### 5.3 Maintenance tips and update setting method after maintenance:

Modify the "used time" on the control panel, it can be cleared after this maintenance, and the system will automatically restart timing.

### 5.4 Gas storage tanks need to be drained regularly

It is recommended to open the blowdown valve every week for blowdown (there is no air pressure in the gas tank).

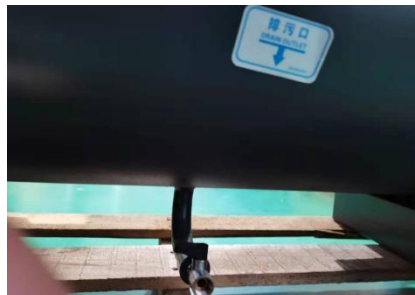

### 5.5 Maintenance plan

| Period(number of hours) | Recommended actions   | Spare parts set                          |
|-------------------------|---|--|
| 100<br>(Or weekly)      | Check the oil level<br>Clean the air filter<br>Clean the radiator (exterior)<br>Gas storage tank blowdown<br>Cleaning and dust removal inside the screw machine   | maintainance                             |
| 500<br>First guarantee  | Replace the special lubricating oil for screw machine<br>Replace the oil filter<br>Replace the oil fine separator<br>Replace the air filter element<br>Check the control switch cable screw<br>Check the seal (each joint, air pipe)<br>Clean the radiator (exterior)<br>Gas storage tank blowdown<br>Cleaning and dust removal inside the screw machine                                    | Consult the manufacturer for spare parts |
| Every2000               | Replace the special lubricating oil for screw machine<br>Replace the oil filter<br>Replace the oil fine separator<br>Replace the air filter element<br>Check the control switch cable screw<br>Check the seal (each joint, air pipe)<br>Clean the radiator (exterior)<br>Gas storage tank blowdown<br>Cleaning and dust removal inside the screw machine                                    | Consult the manufacturer for spare parts |
| 8000                    | ( In addition to maintenance items every 2000 hours )<br>Replace the main engine shaft seal<br>Clean oil and gas separator oil<br>Clean the oil return check valve ( Replace if necessary )<br>Clean the intake valve ( Replace if necessary )<br>Clean the intake valve ( Replace if necessary )<br>control ( Finally changed ) Motor bearing<br>Clean the radiator ( Inside and outside ) | Consult the manufacturer for spare parts |
| 20000                   | ( In addition to maintenance items every 8000 hours )<br>Replace the main engine bearing  | Consult the manufacturer for spare parts |

This maintenance plan is based on all installation and operating parameters recommended by the manufacturer. The manufacturer recommends setting up a compressor maintenance work log for later maintenance.

**The operating hours shown in the table refer to the best use of the machine, and may vary depending on the workplace and the number of cycles.**

## 5.6 Common troubleshooting table (Power and gas must be cut off during manual inspection)

| problem   | reason  | solution   |
|---|---|--|
| Too high oil temperature causes shutdown              | The exhaust temperature of the body is too high (maximum 105°C)   | <ul style="list-style-type: none"> <li>- Check the oil level;</li> <li>- Check the cleanliness of the cooler</li> <li>- Check if the fan is working properly</li> <li>- Check whether the temperature sensor is working properly</li> </ul> <p>The reset button must be pressed before restarting the machine. If high temperature occurs repeatedly, please contact the service center</p>  |
| Motor overheated causing shutdown                     | <ul style="list-style-type: none"> <li>- The voltage is too low.</li> <li>- Motor temperature is too high</li> <li>- Power consumption is too high</li> </ul>   | <ul style="list-style-type: none"> <li>- If the machine is turned on when a fault occurs, check whether the phase sequence is stable;</li> <li>- If the fault occurs, the machine is running, confirm the internal pressure and replace the oil separator</li> <li>- If the current of the motor is higher than the rated current, please contact the technical staff of the service center.</li> <li>- Don't force start, so as not to cause more damage to the compressor control board.</li> <li>- Check whether the voltage and frequency match</li> </ul> |
| Safety valve open                                     | <ul style="list-style-type: none"> <li>- Pressure sensor failure</li> <li>- The set pressure exceeds the set value of the safety valve</li> <li>- Oil fine separator blocked</li> </ul>                       | <ul style="list-style-type: none"> <li>- Check whether the pressure sensor and barometer parameters are normal</li> <li>- Check whether the setting value of the control panel matches the safety valve parameter</li> <li>- Replace the safety valve</li> <li>- Remove and replace the oil fine separator</li> </ul>  |
| The compressor is running but the pressure is too low | <ul style="list-style-type: none"> <li>- The intake valve is not open.</li> <li>- Pressure cannot be increased due to leakage</li> <li>- Transmission element blocking</li> </ul>                             | <ul style="list-style-type: none"> <li>- When the air compressor is stopped and the internal pressure is safe, remove the air filter and check whether the valve can move</li> <li>- Check the pipeline for leaks</li> <li>- Check carefully whether the motor is running but the body is not running.</li> <li>- Contact the service center</li> </ul>  |
| Air filter injection                                  | <ul style="list-style-type: none"> <li>- Oil level is too high</li> <li>- The oil-returning sight glass is dirty</li> <li>- Oil fine separator failure</li> <li>- The intake valve bleeds too fast</li> </ul> | <ul style="list-style-type: none"> <li>- Drain the excess oil during shutdown and check the oil level.</li> <li>- Remove the oil return sight glass and clean it, and replace it if necessary.</li> <li>- Replace the oil fine separator and clean the core tube.</li> </ul>   |



|                            |   |  |
|----------------------------|---|--|
| Main motor overload        | <ul style="list-style-type: none"> <li>- Low voltage</li> <li>- Power phase loss</li> <li>- High pressure in oil and gas barrels</li> </ul>   | <ul style="list-style-type: none"> <li>- Confirm input power</li> <li>- Check whether the three-phase input of the power supply is close to the value and whether it is reliably connected to the terminal</li> <li>- Check the cable for damage</li> <li>- Check whether the ventilation of the main motor is unobstructed.</li> <li>- If the motor has only two-phase input, it should be checked by a qualified technician. (If necessary, replace or repair the motor)</li> <li>- If the pressure difference of the oil and gas barrel is greater than 1 bar, it will cause high energy consumption of the system. Check the system by a qualified technician.</li> <li>- The ambient temperature is too high: ventilation</li> <li>- Restart the machine and press the reset switch on the control panel</li> </ul> |
| Excessive fuel consumption | <ul style="list-style-type: none"> <li>- The faulty oil of the oil fine separator is not suitable for the compressor.</li> <li>-Worn or defective air/oil separator element.</li> <li>- Oil level is too high.</li> </ul> | <ul style="list-style-type: none"> <li>- Change the oil and fill the machine with the oil specified by the manufacturer.</li> <li>- Replace the oil fine separator.</li> <li>- Clean or replace the oil return sight glass.</li> <li>-Replenish oil until the oil level reaches the correct position specified in the manual</li> </ul>  |

## 5.7 Schematic diagram of screw fitting explosion

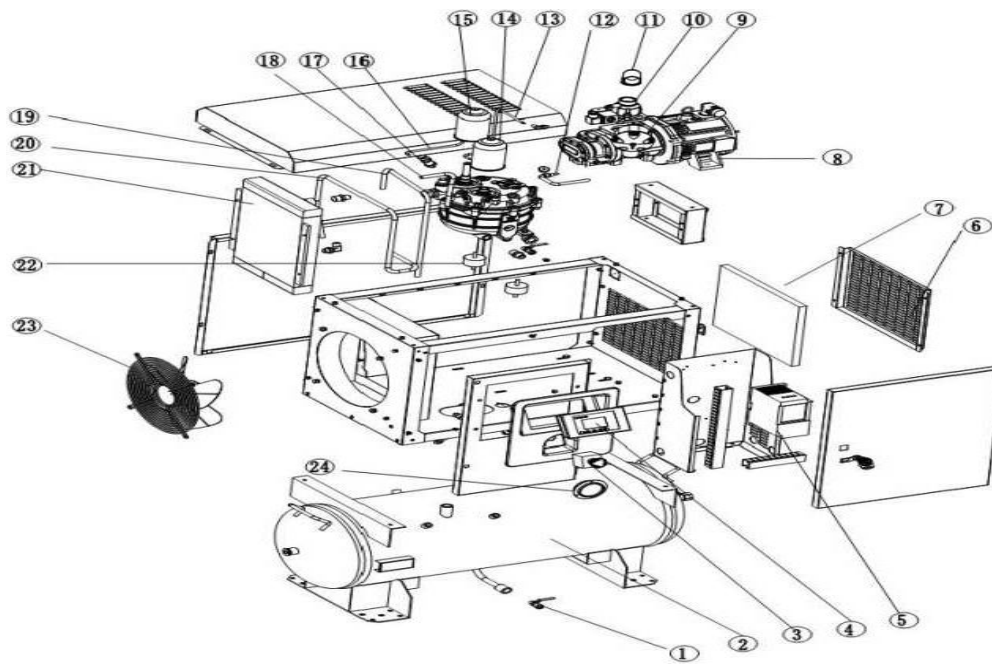

| Serial number | Accessory name               | Material No             | Quantity |
|---------------|------------------------------|-------------------------|----------|
| 1             | Drain valve                  | 40791040000             | 1        |
| 2             | gas tank                     | 30980005100             | 1        |
| 3             | Emergency stop switch        | 39067002544             | 1        |
| 4             | Operation panel              | 37300157094             | 1        |
| 5             | Frequency converter          | 39056240220             | 1        |
| 6             | Net cover                    | /                       | 1        |
| 7             | sponge                       | 67202000000             | 1        |
| 8             | host computer/Motor assembly | 07032750045/07610004030 | 1        |
| 9             | Air filter assembly          | 33150005040             | 1        |
| 10            | Intake valve                 | 40780025304             | 1        |
| 11            | Air filter elbow             | 33150300593             | 1        |
| 12            | Temperature Sensor           | 40720100020             | 1        |
| 13            | Unloading pipe               | /                       | 1        |
| 14            | Oil filter                   | 3335L962202             | 1        |
| 15            | Oil and gas separator        | 3335L719200             | 1        |
| 16            | Oil return pipe              | /                       | 1        |
| 17            | Safety valve                 | 40800004370             | 1        |
| 18            | Oil return pipe 1            | /                       | 1        |
| 19            | trachea                      | /                       | 1        |
| 20            | Oil return pipe 2            | /                       | 1        |
| 21            | Cooler                       | 31030001001             | 1        |
| 22            | Cushion                      | 21165009010             | 1        |
| 23            | cooling fan                  | 20116300380             | 1        |
| 24            | Pressure gauge               | 40728001004             | 1        |

# Reference circuit wiring diagram

Figure1

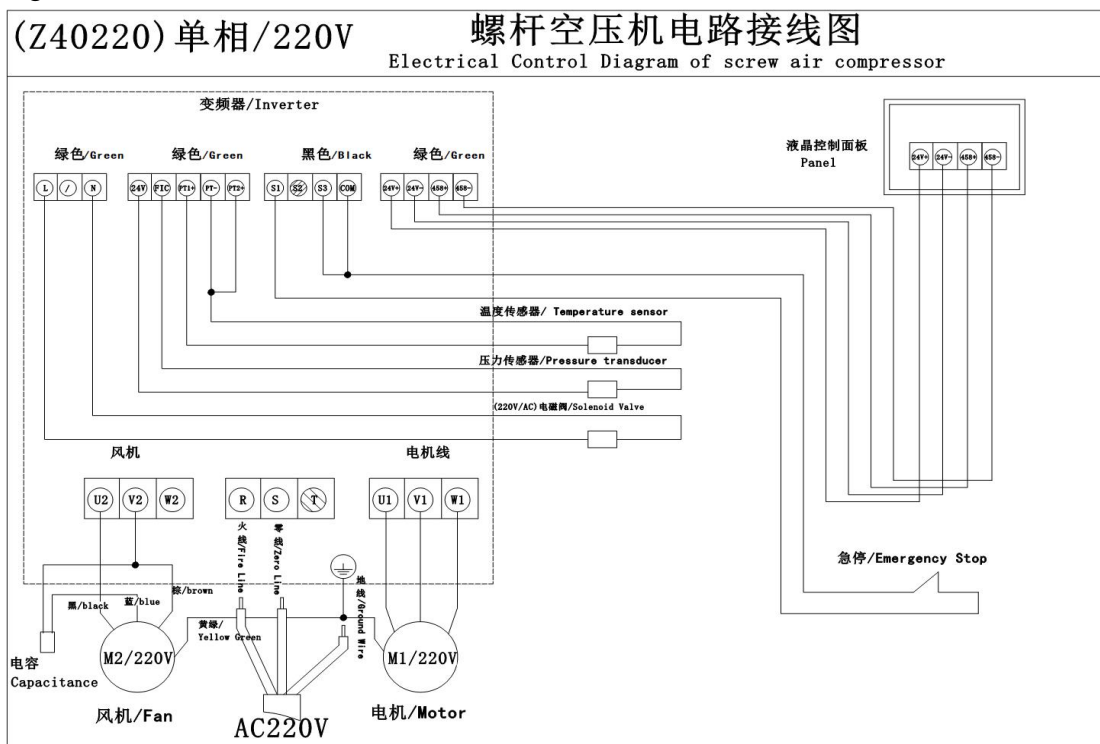

Figure2

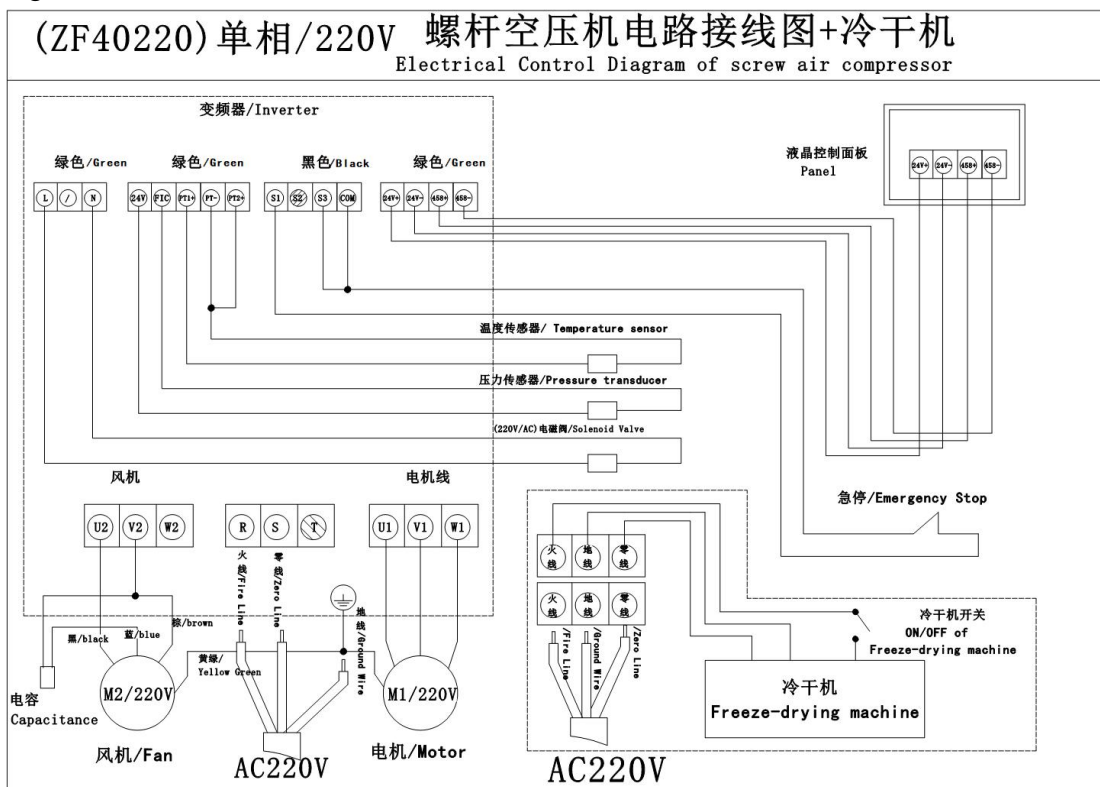

Figure3

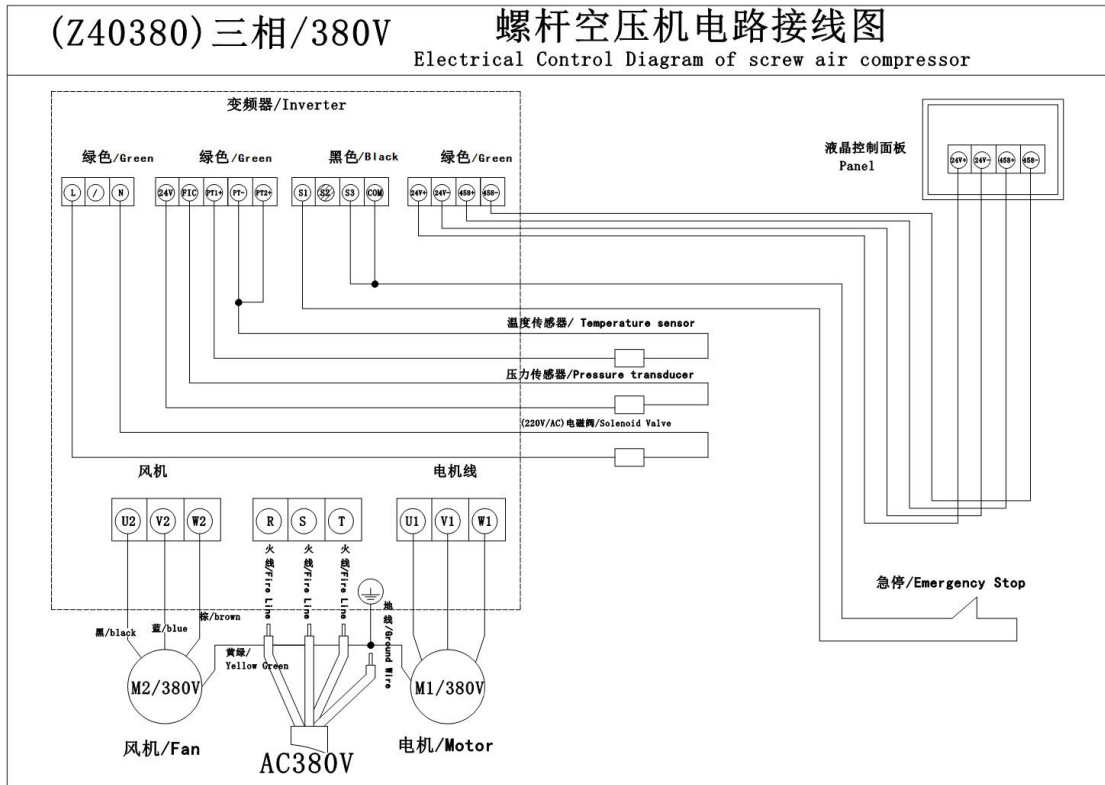

Figure4

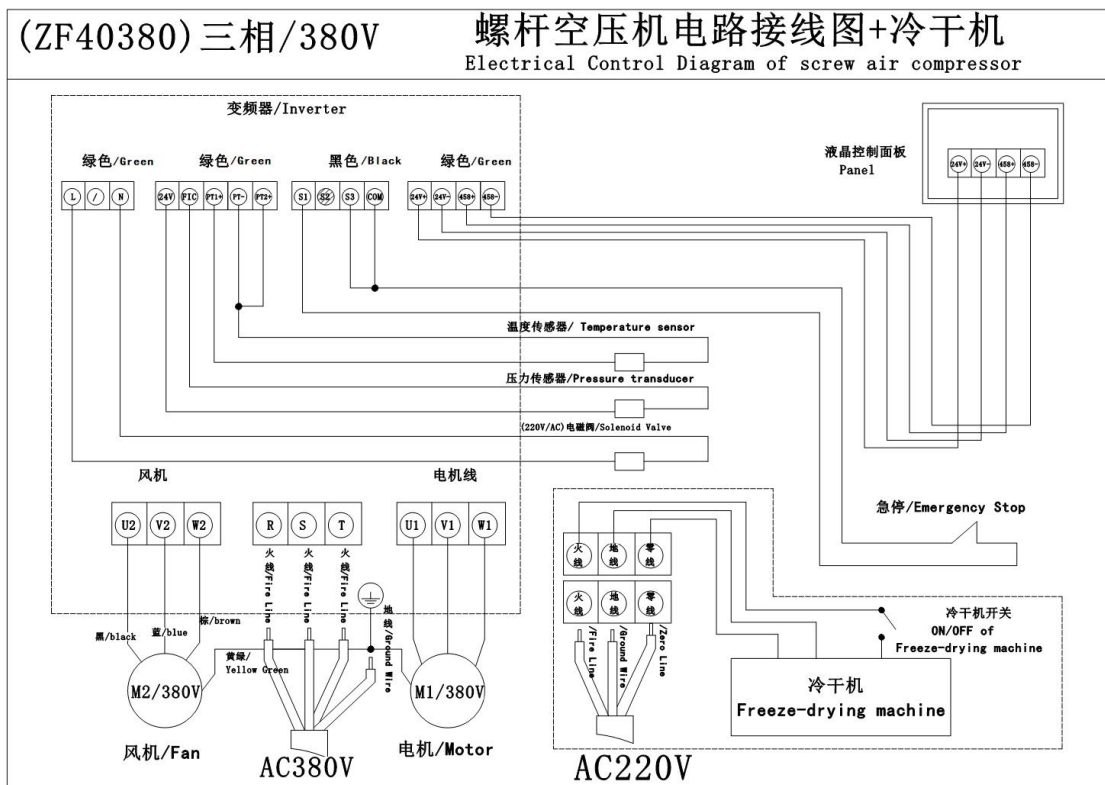

Figure5

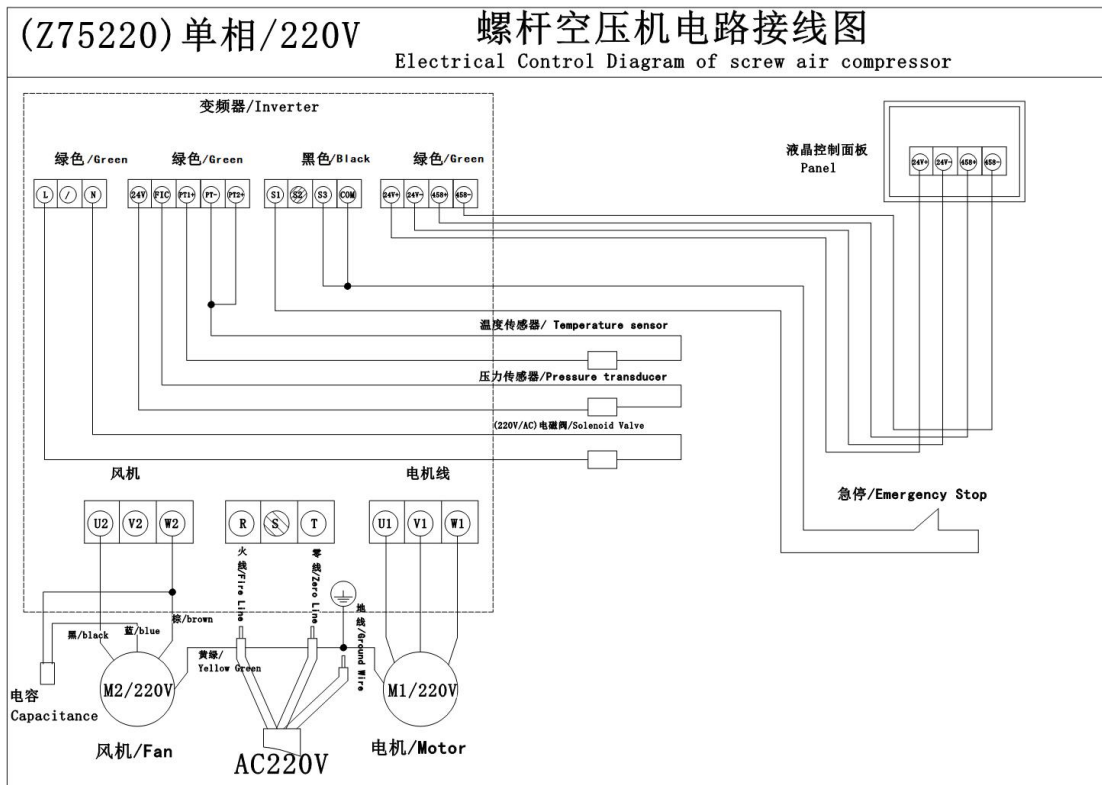

Figure6

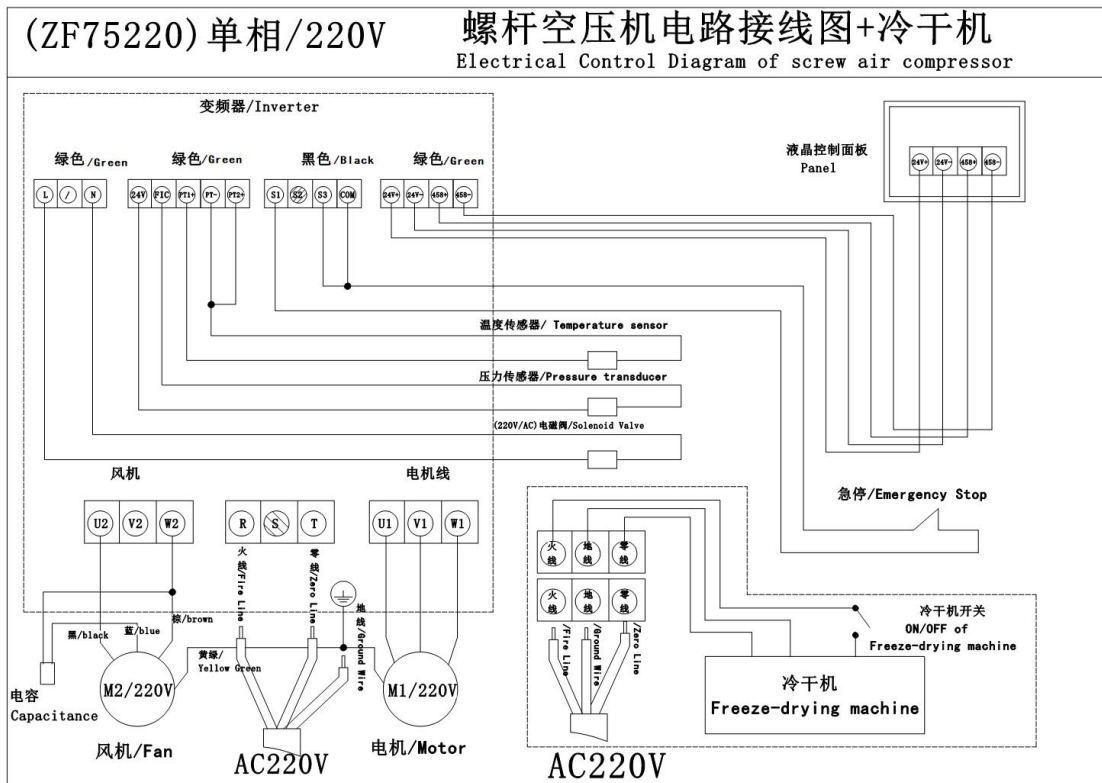

Figure7

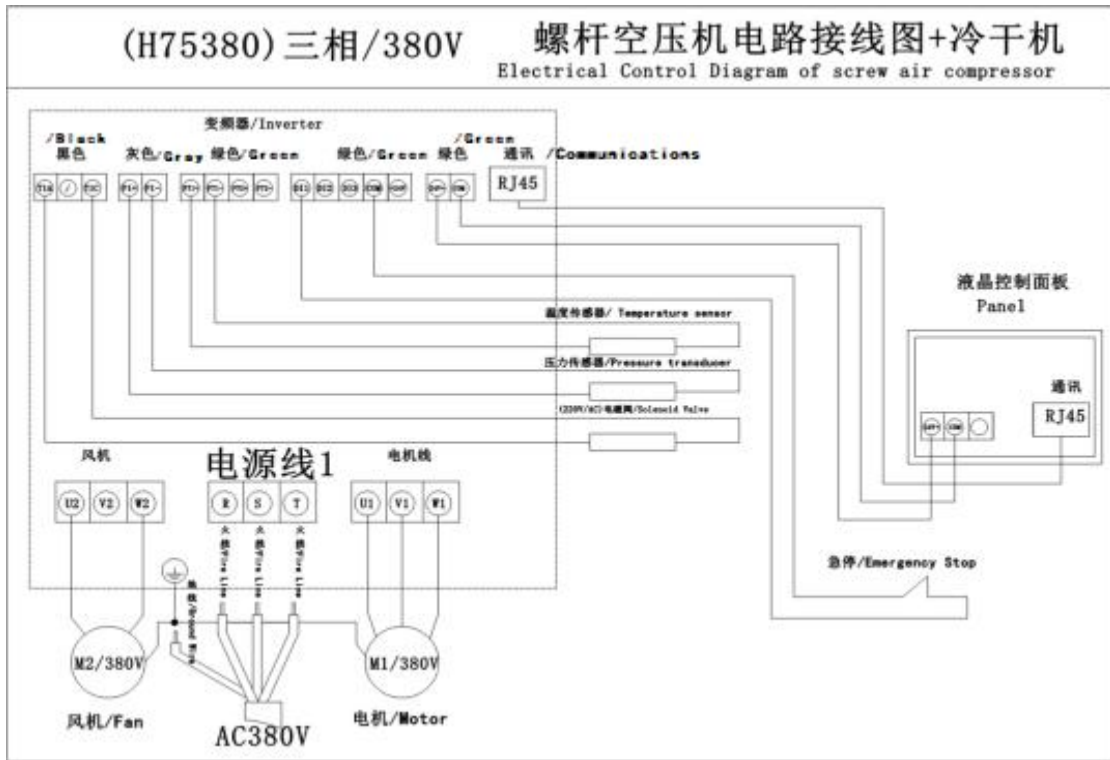

Figure8

