

USE AND MAINTENANCE MANUAL

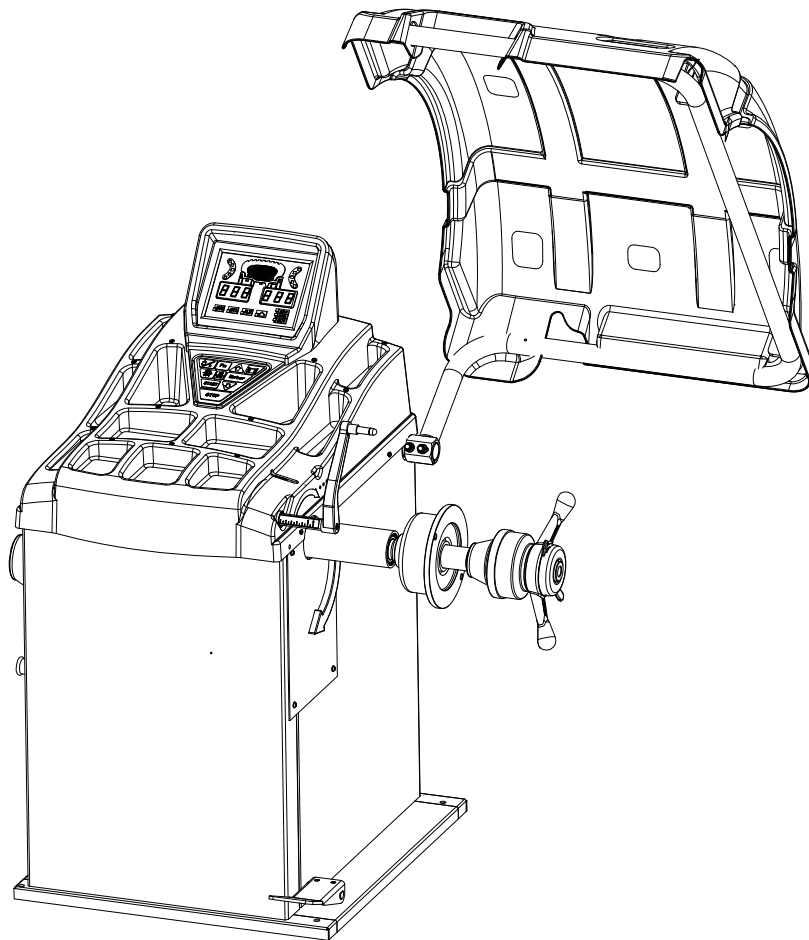

WHEEL BALANCER WITH MICRO-PROCESSOR

GM - U90 PRO



PRINTING CHARACTERS AND SYMBOLS

Throughout this manual, the following symbols and printing characters are used to facilitate reading:

	Indicates the operations which need proper care
	Indicates prohibition
	Indicates a possibility of danger for the operators
BOLD TYPE	Important information

CONTENTS

1	INTRODUCTION	4
	1.1 INTRODUCTION	4
	1.2 MACHINE IDENTIFICATION DATA	4
	1.3 MANUAL KEEPING	4
2	GENERAL INFORMATION	5
	2.1 GENERAL SAFETY	5
	2.2 STANDARD SAFETY DVICES	5
	2.3 INTENDED USE	5
	2.4 GENERAL CHARATERISTICS	5
	2.5 MACHINE DESCRIPTION	6
	2.6 TECHNICAL SPECIFICATION	6
3	TRANSPORTATION, UNPACKING AND STORAGE	7
	3.1 TRANSPORTATION	7
	3.2 UNPACKING	7
	3.3 STORAGE	7
4	COMMISSIONING	8
	4.1 SPACE REQUIRED	8
	4.2 SHAFT ASSEMBLY	8
	4.3 WHEEL GUARD MOUNTING	9
	4.4 ELECTRIC CONNECTION	9
5	CONTROL PANEL AND MENU FUNCTION	10
	5.1 DISPLAY PANEL	10
	5.2 CONTROL PANEL	11
	5.3 MENU FUNCTION	12
6	OPERATION OF THE WHEEL BALANCER	13
	6.1 BASIC OPERATION INFORMATION	13
	6.2 MOUNTING WHEEL ON SHAFT	13
	6.3 WHEEL DATA ENTRY	15
	6.4 BALANCING MODE	16
	6.4.1 DYNAMIC MODE	16
	6.4.2 STATIC MODE	16
	6.4.3. STANDARD ALU MODE	17
	6.4.4 UNBALANCE OPTIMIZATION (OPT)	18
7	SET UP	19
	7.1 SELF-DIAGNOSIS	19
	7.2 SELF-CALIBRATION	20
8	MAINTENANCE	21
9	ERRORS AND TROUBLE-SHOOTING	22
10	ACCESSORIES	23

CHAPTER 1 – INTRODUCTION

1.1 INTRODUCTION

Thank you for purchasing a product from the line of wheel balancer. The machine has been manufactured in accordance with the very best quality principles. Follow the simple instructions provided in this manual to ensure the correct operation and long life of the machine. Read the entire manual thoroughly and make sure you understand it.

1.2 MACHINE IDENTIFICATION DATA

A complete description of the “Wheel balancer model” and the “Serial number” will make it easier for our technical assistance to provide service and will facilitate delivery of any required spare parts. For clarity and convenience, we have inserted the data of your machine in the box below. If there is any discrepancy between the data provided in this manual and that shown on the name plate fixed to the wheel balancer, the latter should be taken as correct.

LOGO		
Type:		
Volt	Amp	Kw
Ph	Hz	
Year of manufacturing:		

1.3 MANUAL KEEPING

For a proper use of this manual, the following is recommended:

- Keep the manual near the lift, in an easily accessible place.
- Keep the manual in an area protected from the damp.
- Use this manual properly without damaging it.
- Any use of the machine made by operators who are not familiar with the instructions and procedures contained herein shall be forbidden.

This manual is an integral part of the manual: it shall be given to the new owner if and when the machine is resold.

	The illustrations have been made out of prototypes pictures. It is therefore possible that some parts or components of standard production differ from those represented in the pictures.
---	--

TO THE READER

Every effort has been made to ensure that the information contained in this manual is correct, complete and up-to date. The manufacturer is not liable for any mistakes made when drawing up this manual and reserves the right to make any changes due the development of the product, at any time

CHAPTER 2 – GENERAL INFORMATION

2.1 GENERAL SAFETY

- The wheel balancing machine should only be used by duly authorized and trained personnel.
- The wheel balancing machine should not be used for purposes other than those described in the instruction manual.
- Under no way should the wheel balancing machine be modified except for those modifications made explicitly by **THE MANUFACTURER**.
- Never remove the safety devices. Any work on the machine should only be carried out by specialist personnel.
- Avoid using strong jets of compressed air for cleaning.
- Use alcohol to clean plastic panels or shelves (**AVOID LIQUIDS CONTAINING SOLVENTS**).
- Before starting the wheel balancing cycle, make sure that the wheel is securely locked on the adapter.
- The machine operator should avoid wearing clothes with flapping edges. Make sure that unauthorized personnel do not approach the machine during the work cycle.
- Avoid placing objects inside the base as they could impair the correct operation of the machine.

2.2 STANDARD SAFETY DVICES

- Stop key for stopping the wheel under emergency conditions.
- A wheel guard of high impact plastic that is designed to prevent the counterweights from flying out in any directing except toward the floor.
- A switch interlock system prevents the machine from starting if the guard is not lowered and stops the wheel whenever the guard is raised.

2.3 INTENDED USE

- This wheel balancer has been designed and manufactured exclusively for balancing wheel with a maximum diameter of 1000mm and maximum weight of 75kg. The calibration system is sufficient to cover different wheels from motorcycles to cars.
- In particular **THE MANUFACTURER** cannot be held responsible for any damage caused through the use of wheel balancer for purposes other than those specified in this manual, and therefore inappropriate, incorrect and unreasonable.

2.4 GENERAL CHARATERISTICS

- Automatic weight positioning where the balancing weight has to be applied
- Automatic braking after spin
- Automatic start/stop when the hood is lowered/raised
- Automatic application of adhesive weights on unbalanced positions
- STOP pushbutton to stop the machine immediately
- Static and dynamic balancing modes
- Four ALU modes
- Rapid optimization (OPT)
- Self-diagnosis
- Self-calibration
- Exceptional stability in reading the unbalance between planes

- Display in grams or ounces, in mm or inch
- Anchor-down installation unnecessary

2.5 MACHINE DESCRIPTION

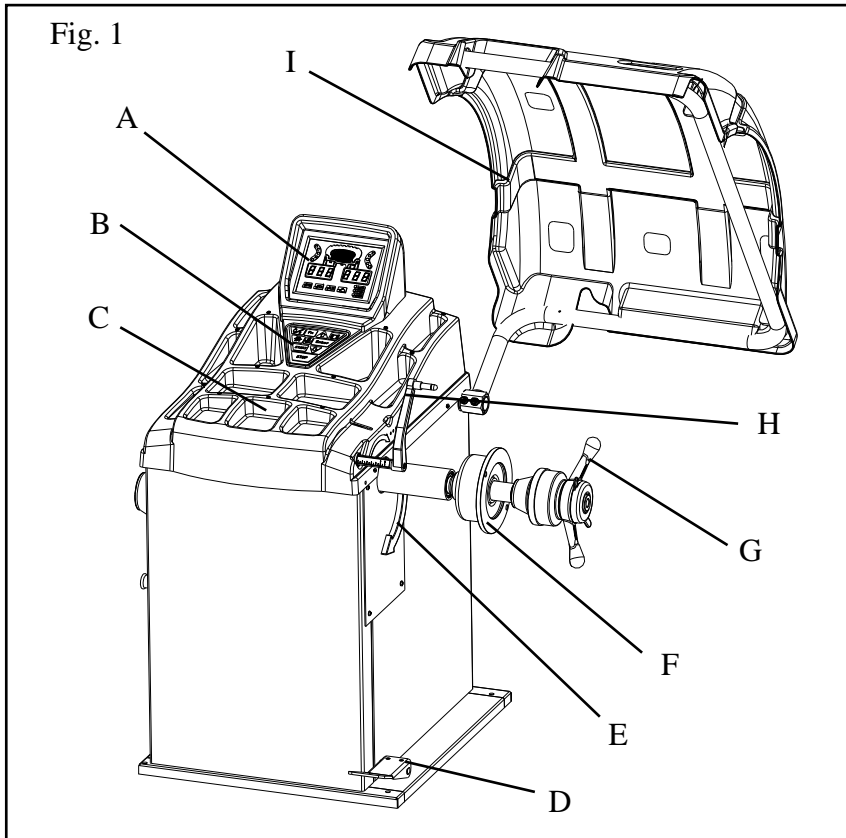

- A: Display panel
- B: Control panel
- C: Wheel weight tray/cover
- D: Foot brake
- E: LED lighter
- F: Wheel shaft
- G: Quick locking nut
- H: Measuring gauge
- I: Wheel guard

2.6 TECHNICAL SPECIFICATION

Max. wheel weight	75kg
Wheel diameter	39" (1000mm)
Rim diameter	10" - 32" (255 - 810mm)
Wheel width	1.5" - 20" (39 - 510mm)
Balancing precision	± 1g
Resolution	1.4 degrees
Cycle time	7 s
Max. balancing speed	180 rpm
Power supply	110V/220V/230V-1Ph
Motor power	290w
Noise level	< 75 dbA

CHAPTER 3 – TRANSPORTATION, UNPACKING AND STORAGE

3.1 TRANSPORTATION

- The machine must be transported in its original packaging and kept in the position shown on the package itself.
- The packaged machine may be moved by means of a fork lift truck of suitable capacity. Insert the forks at the points shown in figure 2.

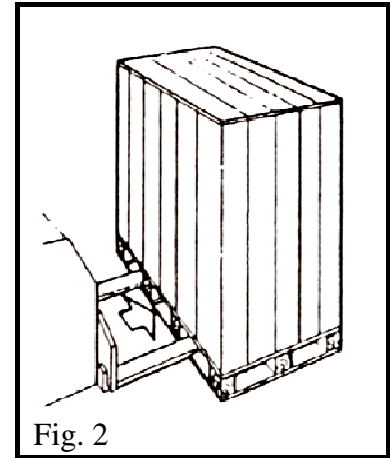

Fig. 2

3.2 UNPACKING

- Remove the protective cardboard and the nylon bag.
- Remove the fixing bolts from the packing pallet.
- Check that the equipment is in perfect condition, making sure that no parts are damaged or missing. Use fig. 1 for reference.



If in doubt do not use the machine and contact your retailer.

3.3 STORAGE

Packages must be stored in a covered place, out of direct sunlight and in low humidity, at a temperature between -10°C and $+40^{\circ}\text{C}$.

In the event of storage for long periods of time, be sure to disconnect all sources of power and grease the clamp sliding guides on the turntable to prevent them from oxidizing.

CHAPTER 4 – COMMISSIONING

4.1 SPACE REQUIRED



When choosing the place of installation, make sure that it complies with current safety at work regulations.

Do not operate the balancer while it is on the pallet.

- The balancer must be located on a flat floor of solid construction, preferably concrete. The balancer must sit solidly on its three feet. If the balancer is not leveled, the balancer will not function properly and may produce inaccurate balance readings.
- Select a location for the balancer that provides a level, solid floor, and adequate clearance around and above the balancer. The place of installation must also provide at least the space shown in pictures Fig. 3 and Fig. 4 so as to allow all parts of the machine to operate correctly and without any restriction.
- Make sure the location selected has enough room above and behind the machine so the wheel guard can be raised completely. The location must also provide working room for mounting and removing wheels. Make sure the area has adequate lighting.
- If the machine is installed outside it must be protected by a lean-to.

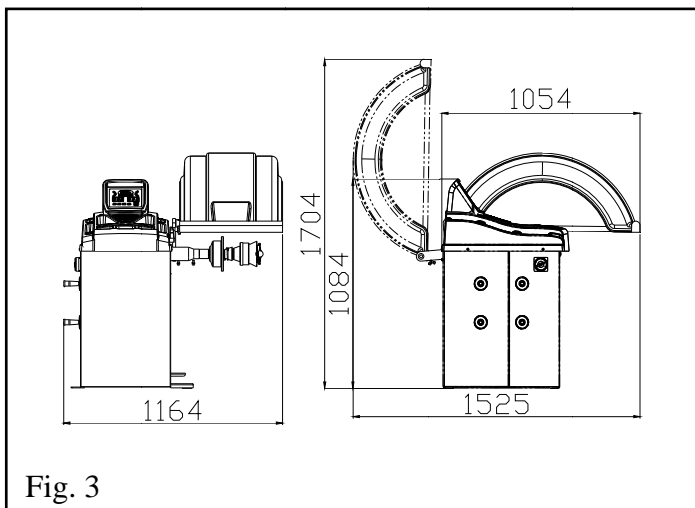

Fig. 3

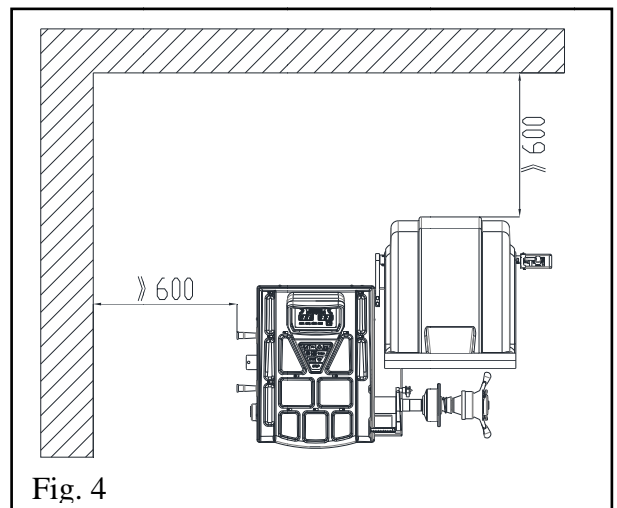

Fig. 4

4.2 SHAFT ASSEMBLY

- Mount the thread end piece (A) onto the shaft by screwing the retaining screw (B).
- Tighten the retaining screw (B) thoroughly by using the supplied wrench (C).

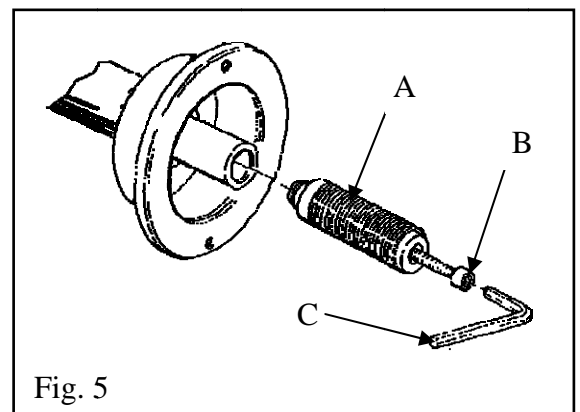
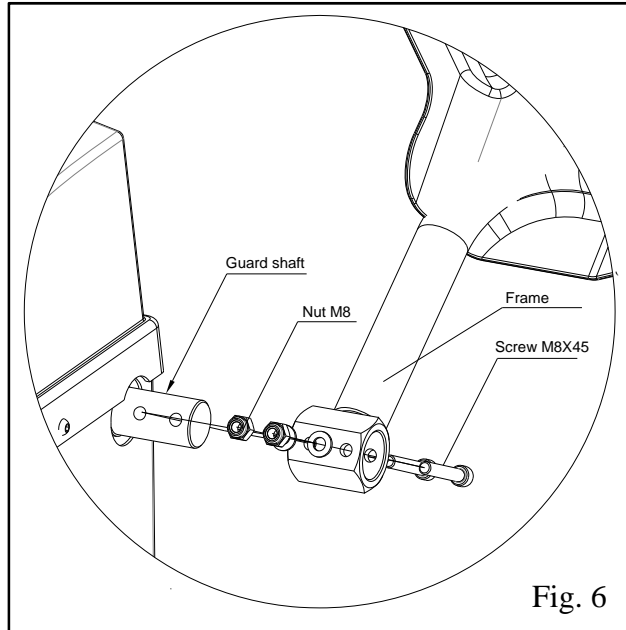

Fig. 5

4.3 WHEEL GUARD MOUNTING

- Mount the wheel guard onto the guard arm by the supplied screws according to Fig. 6.
- Check the micro switch is held down when the wheel guard is closed. Adjust it if necessary.



Do not clean on the guard during the wheel balancing cycle.

4.4 ELECTRIC CONNECTION



Any electric connection job must be carried out by professionally qualified personnel.

Make sure that the power supply is right.

Make sure the connection of the phases is right. Improper electrical hook-up can damage motor and will not be covered under warranty.

- The machine is supplied with a single phase mains cable plus earth (ground)
- Check to make sure the characteristics of your systems correspond to those required by the machine. The supply voltage (and mains frequency) is given on the machine nameplate. It cannot be changed.
- Connect the machine to the main electric power supply. If the machine does not include the electric plug, the user must set one, which must conform to the voltage of the machine, in compliance with the regulations in force.
- The machine should not be started up without proper earthing.

CHAPTER 5 – CONTROL PANEL AND MENU FUNCTION

5.1. DISPLAY PANEL

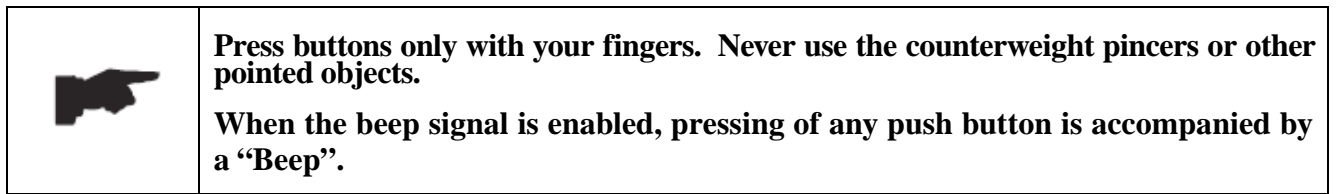
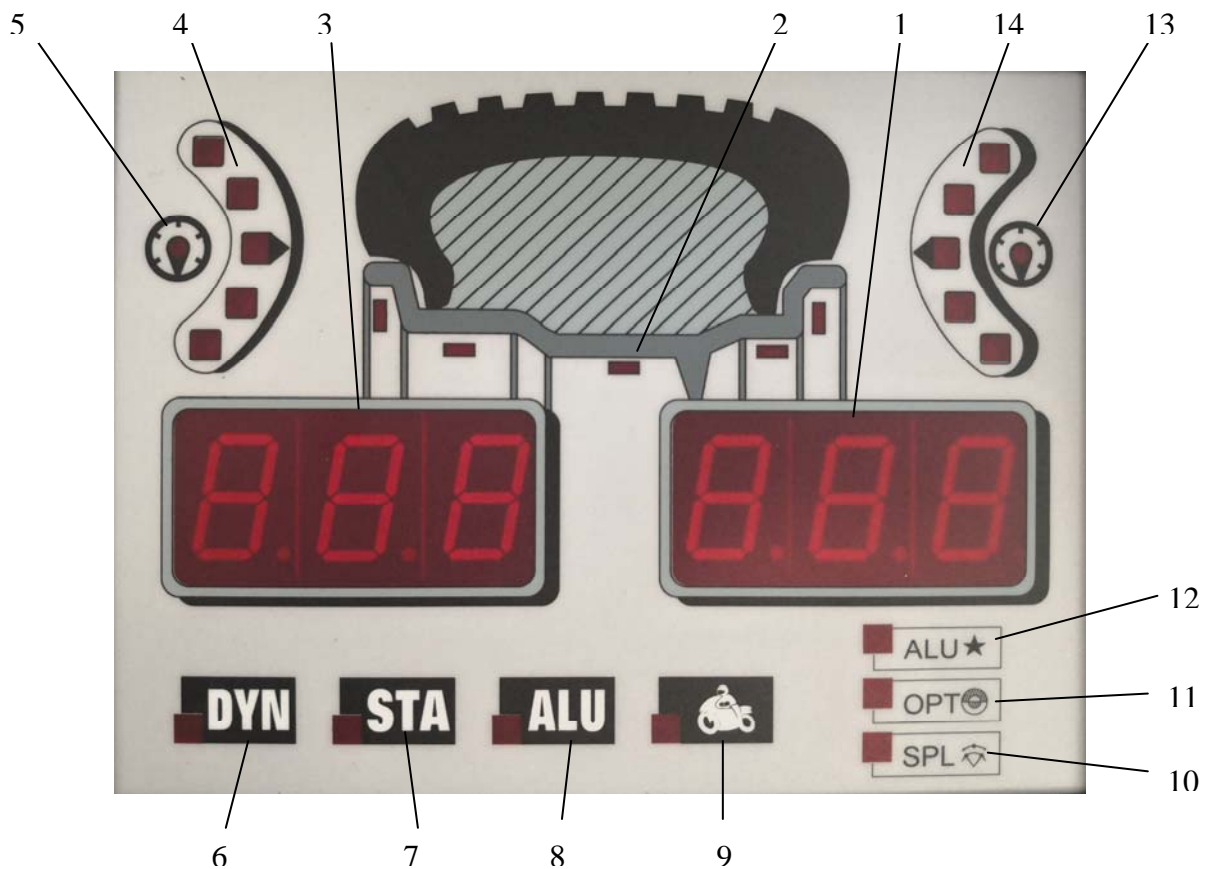

Fig. 7 – DISPLAY PANEL



1. Digital readouts, AMOUNT OF UNBALANCE outside
2. Indicators, position of application for correction weights
3. Digital readouts, AMOUNT OF UNBALANCE inside
4. LED indicator, POSITION OF UNBALANCE inside
5. Indicator, inner adhesive weight position at 6 o'clock
6. Indicator, DYNAMIC mode selected
7. Indicator, STATIC mode selected
8. Indicator, ALU mode selected
9. Indicator, MOTORCYCLE mode selected
10. Indicator, SPLIT function (unavailable for this mode)
11. Indicator, OPT
12. Indicator, ALU☆ mode selected (unavailable for this mode)
13. Indicator, outer adhesive weight position at 6 o'clock
14. LED indicator, POSITION OF UNBALANCE outside

5.2. CONTROL PANEL

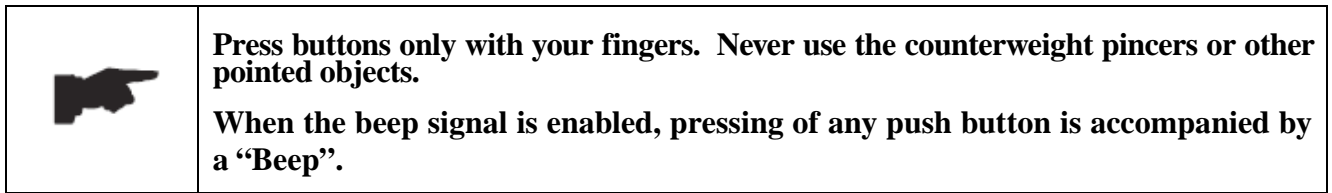
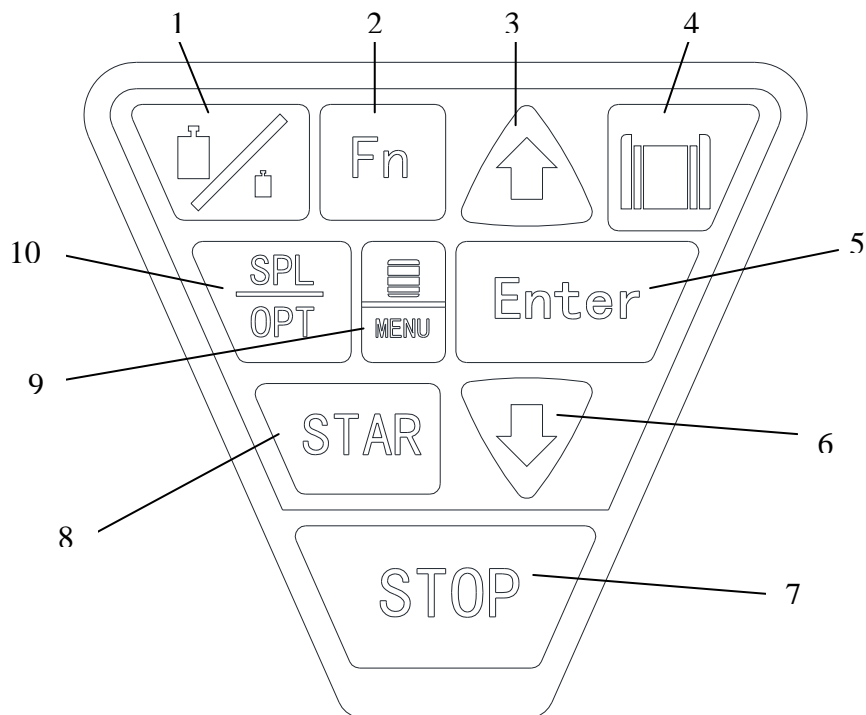
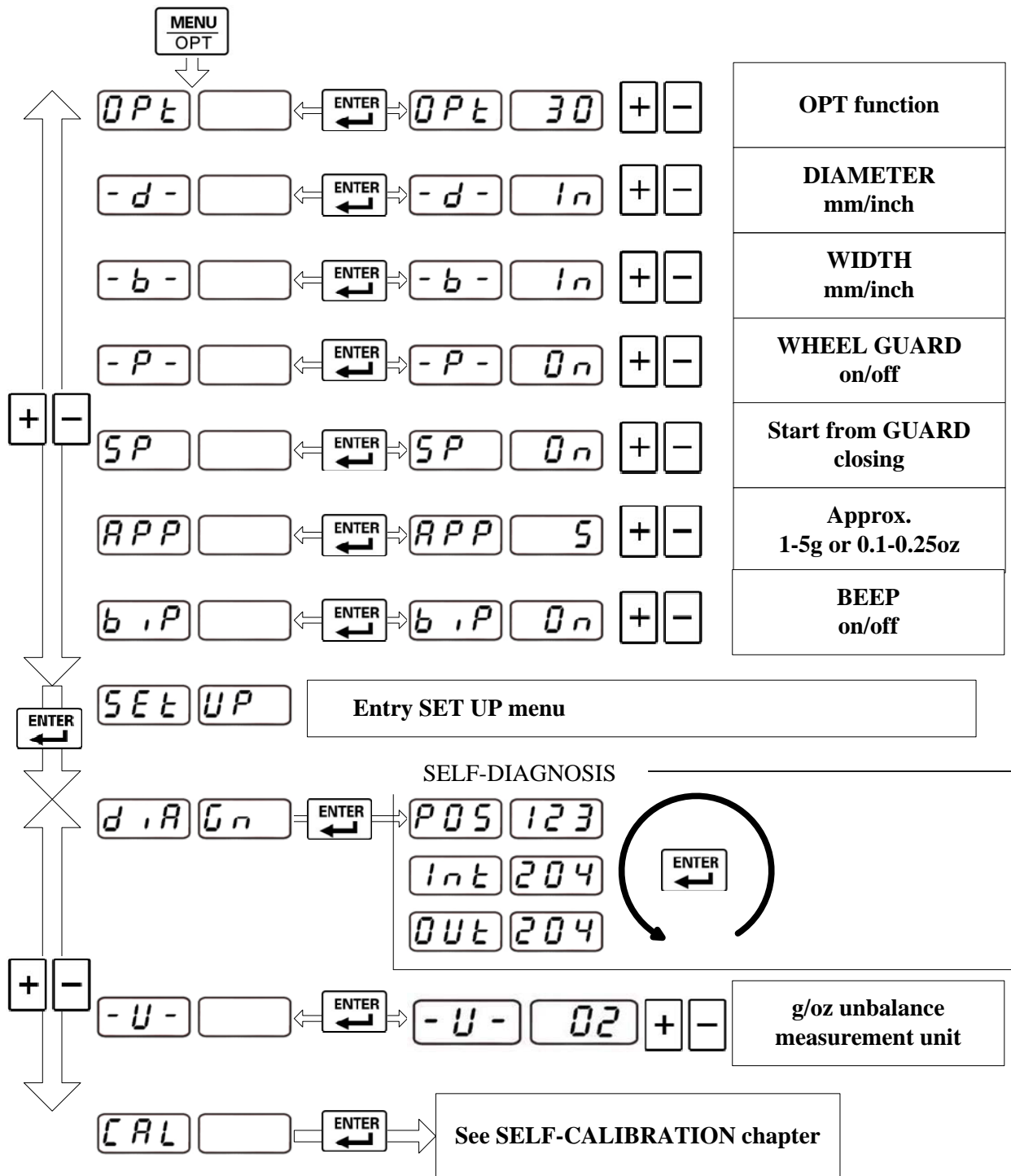

Fig. 8 – CONTROL PANEL



1. Unbalance reading selection
2. Unbalance mode selection
3. Function selection (UP)
4. Rim parameters selection
5. Confirm button
6. Function selection (DOWN)
7. Emergency/home button
8. Start button
9. SET UP MENU button
10. OPT function button

5.3 MENU FUNCTIONS (figure 9)



Press **STOP** to exit any function.

CHAPTER 6 – OPERATION OF THE WHEEL BALANCER

	<p>Do not use the machine until you have read and understood the entire manual and the warning provided.</p> <p>The wheel guard must not be opened before the wheel stops. The STOP button serves to stop the machine immediately in emergencies.</p> <p>Do not permit the control panel to get wet!</p>
---	---

	<p>Chains, bracelets, loose clothing or foreign objects in the vicinity of the moving parts can represent a danger for the operator.</p>
---	---

6.1 BASIC OPERATION INFORMATION

	<p>The initial screen when switching on is in DYNAMIC mode.</p>
---	--

- Mount the wheel on the shaft of machine. Use the most appropriate mounting method. Always remove any weight attached to the wheel.
- Switch on the machine.
- Measure and entry the wheel data.
- Select the most appropriate balancing mode. The initial screen when switching on is in DYNAMIC mode.
- Start the machine. Performing a spin can be started by pressing START button or closing the wheel guard if START FROM GUARD CLOSING is enabled.
- When the figures have been established, the spin is automatically braked to a stop in the correction zone. After the machine stops, the unbalanced amounts are shown on the digital readouts.
- Rotate the wheel slowly by hand until LED indicators light up to indicate the correct angular wheel position to apply the counterweights.
- Apply weights on the position for correction.
- With the counterweights correctly in position, restart the machine to check the correct balancing of the wheel.
- Reset the balancing mode referring to Fig. 8.

6.2 MOUNTING WHEEL ON SHAFT

	<p>Avoid back injury, seek assistance when lifting a heavy wheel onto the balancer shaft.</p> <p>Make sure to tighten the quick locking nut. Failure to do so may result in serious personal injury.</p>
---	--

- Select the most appropriate mounting method for the wheel you are balancing. Using the proper method ensures secure mounting and safe balancer operation, and prevents damage to the wheel.

- On most wheels, the inner side of the wheel hub usually has the most uniform surface for wheel balancing. Always center the wheel by the most uniform shaped side of the hub to achieve the most accurate balance.
- Regardless of mounting type, always make sure that the wheel is forced firmly against the shaft faceplate and that the quick locking nut is tightened. To assist in centering the wheel properly, rotate the wheel and the shaft while tightening the nut.

6.2.1 STANDARD BACK CONE MOUNTING (ref. Fig. 10)



Most steel wheels can be mounted properly using this method. The wheel is centered on a cone from the inner side of the hub.

- Select the cone that best fits the centre hole in the wheels. Slide the cone onto the shaft with the large end towards the faceplate.
- Lift the wheel onto the shaft and centre it on the cone.
- Attach the pressure cup to the quick locking nut and install the assembly onto the shaft. Tighten securely.

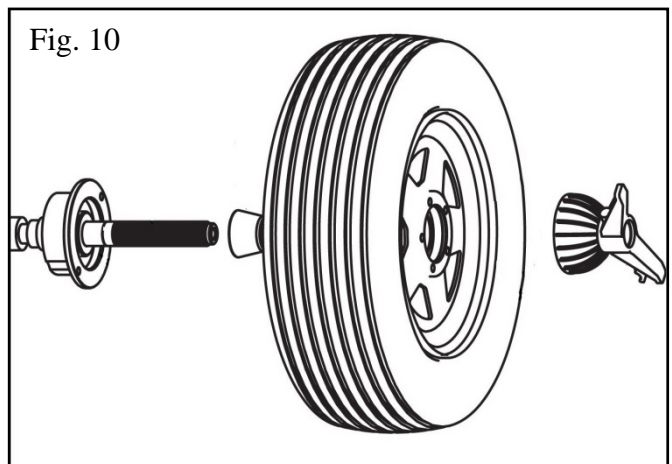

6.2.2 STANDARD FRONT CONE MOUNTING (ref. Fig. 11)

A wheel should be centered by the outer side of the hub only when the inner surface will not provide an accurate surface to center on.

- Select the cone that best fits the center hole in the wheel.
- Lift the wheel onto the shaft and slide it back against the shaft faceplate.
- Slide the cone onto the shaft and into the center of the wheel. You will need to lift the wheel to seat the cone in the centre hole.
- Install the quick locking nut (without the pressure cup) onto the shaft. Tighten securely against the cone.

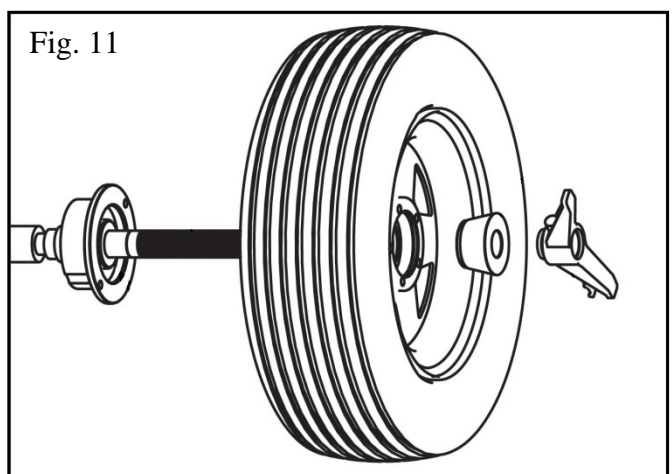

6.3 WHEEL DATA ENTRY

 Before balancing a wheel, wheel data must be entered.

6.3.1 WHEEL DATA (ref. Fig.12)

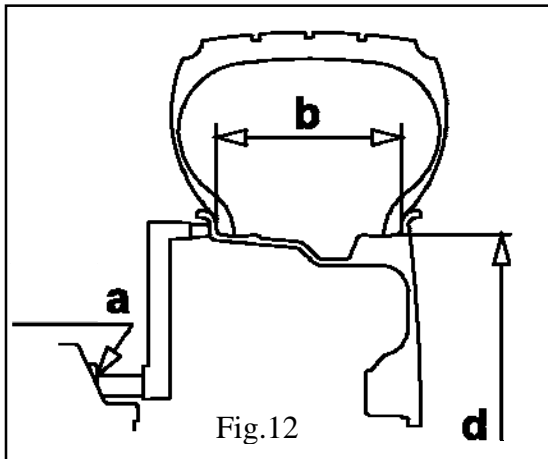

A: The distance, measured from the machine to the inner side of the rim

B: The wheel width

D: The wheel diameter

6.3.2 MANUAL ENTRY (ref. Fig. 14)

- Measure the distance from the machine (“0” on the gauge) to the inner side of the rim as shown in the figure 11. Entry the data manually.
- Measure the width at the rim with the supplied caliper as shown in the figure 13. Entry the data manually.
- Check the diameter indicated on the rim. Entry the data manually.

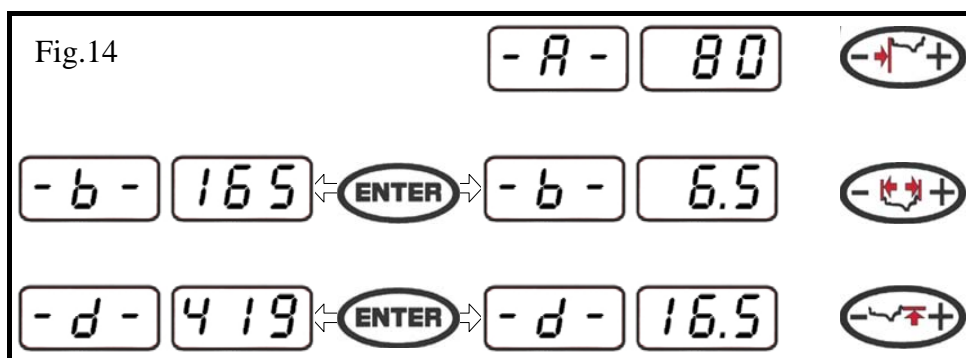
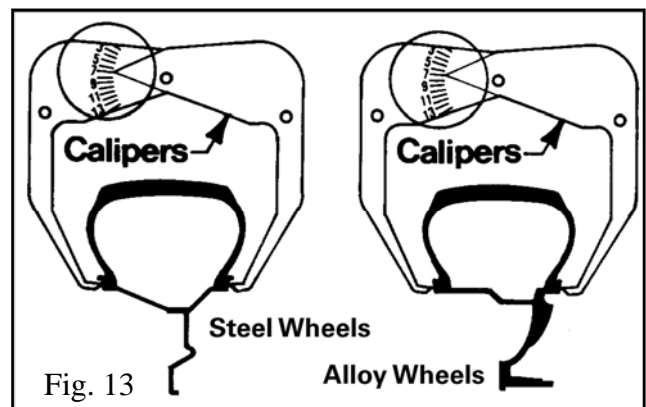

6.4 BALANCING MODE

6.4.1 DYNAMIC MODE

The dynamic mode is used for most passenger and light truck wheels using the most common location for corrective weights. Clip-on weights are placed on the inner and outer sides of the rim at 12 o'clock position.

On the initial screen press **START** → **00** **00**

Fig. 15

Correction of outer side

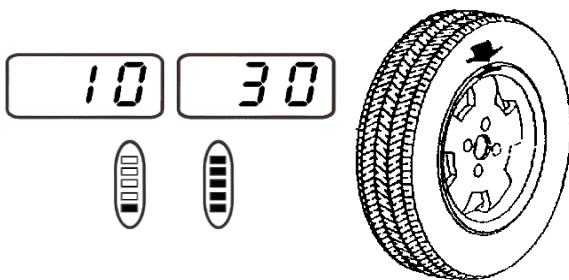

Correction of inner side

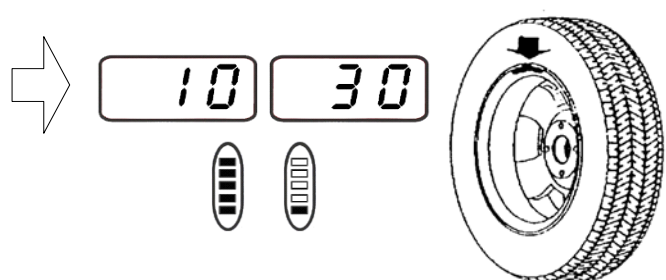

6.4.2 STATIC MODE

The static mode is used for motorcycles or narrow wheels when it is not possible to place the counterweights on both sides of the rim. Clip a single weight at 12 o'clock position on one of sides of the rim or in centre of wheel according to the diameter of the wheel mounted.

Press **Fn** to select "Static mode".

When the LED indicator STA lights up and then press **START** **00** **00**

Fig. 16

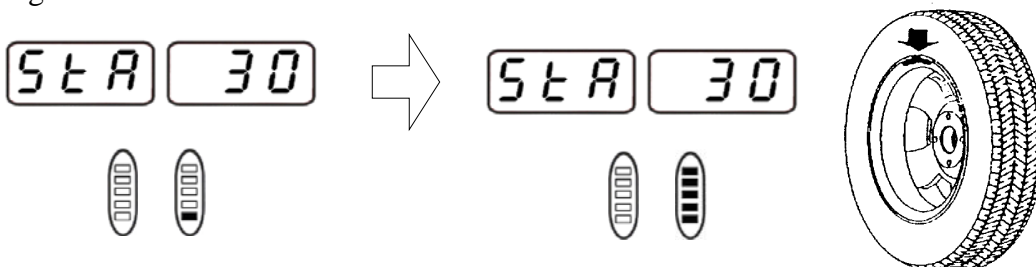

6.4.3 STANDARD ALU MODE

All the ALU modes are dynamic balance. Choose the option that best fits the available locations as shown in the figure 17



From the measurement screen, press  to select the modes **ALU1** → **ALU2** → **ALU3** → **ALU4**.

Fig. 17





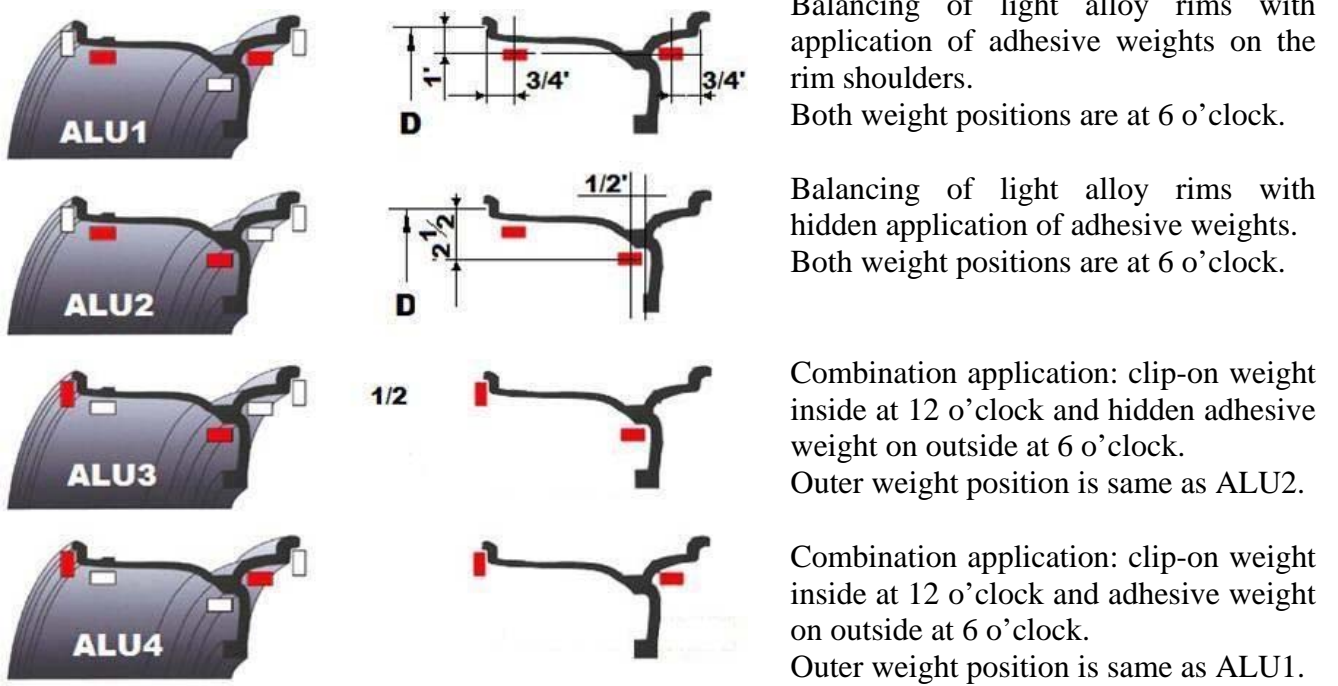

6.4.4 UNBALANCE OPTIMIZATION (OPT)

This function is used to determine the best mating of tire and rim that will result in the least amount of total unbalance of the wheel. It serves to reduce the amount of weight to be added in order to balance the wheel. It is suitable for static unbalance exceeding 30g.

	A high unbalance may indicate the improper mounting of the wheel on the balancer. If the unbalance is excessive, it may be prudent to replace the rim, the tire, or both. If either is replaced, do not continue with optimization. Balance the new tire and rim and evaluate the readings.
---	--

After performing the static balance, press . If the unbalance amount shown on the digital readouts is exceeding 30g, the digital readouts display “YES” “OPT”. In this case, start OPT function:

- Mark with chalk reference points on the same position of both the tire and the rim.
- Rotate the wheel to move the marked points to 12 o'clock position.
- Press  to memorize the position.
- Remove the wheel from the balancer.
- Remove the tire from the rim with the aid of a tire changer.
- Only mount the rim on the balancer.
- Rotate the rim to move the mark to 12 o'clock position.
- Press   .
- Press  to spin the rim.

After performing the spin:

- Rotate the rim until LED indicator for outside (Fig. 7 – 14) lights up.
- Mark with chalk on the rim at 12 o'clock position.
- With the aid of the tire changer, refit the wheel with the reference marks coinciding between the rim and tire.

CHAPTER 7 – SET UP

7.1 SELF-DIAGNOSIS

Fig. 18

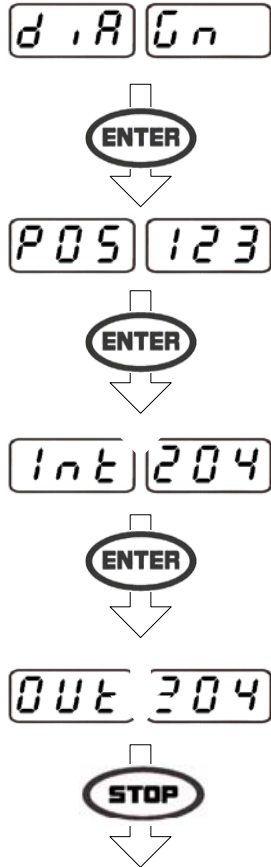

Diagnosis of phase



Rotate the wheel in direction of rotation, the readouts display from 0 to 255.
Rotate the wheel in reverse direction of rotation, the readouts displays from 255 to 0.

Diagnosis of inner piezo

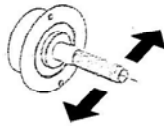

Push the balancing shaft from any direction, the readouts change.

Diagnosis of outer piezo

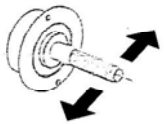

Push the balancing shaft from any direction, the readouts change.

Press **STOP** to end SELF-DIAGNOSIS,

7.2 SELF-CALIBRATION

To access SELF-CALIBRATION menu, refer to Fig. 9.

For the self-calibration proceed as follows:

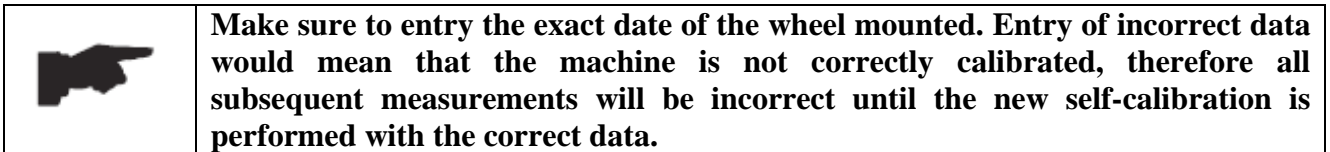
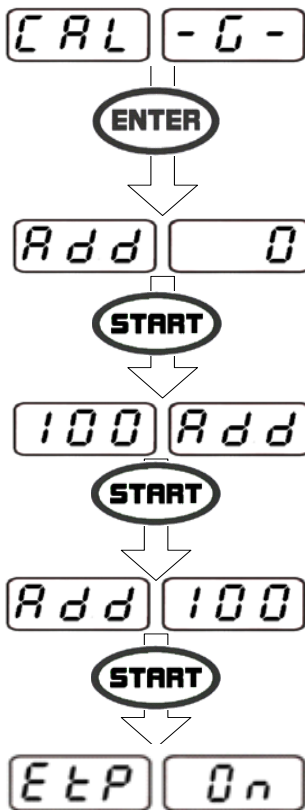

Fig. 19



Mount a wheel with average data on the shaft.
Entry the exact data of the wheel mounted.

Perform the first spin under normal condition

Rotate the wheel manually to 12 o'clock and apply 100g weight on the inner side of the rim.
Start the second spin.

After the second spin, rotate the wheel manually to 12 o'clock, then remove the 100g weight applied on the inner side of the rim and apply 100g weight on the outer side of the rim.

Start the third spin.

After the spin, **E t P** **0 n** flashes seconds to exit the weight calibration automatically.

Remove the 100g weight from the wheel.

CHAPTER 8 – MAINTENANCE

8.1 GENERAL WARNINGS



Unauthorized personnel may not carry out maintenance work.

- Regular maintenance as described in the manual is essential for correct operation and long lifetime of the machine.
- If maintenance is not carried out regularly, the operation and reliability of the machine may be compromised.



Before carrying out any maintenance work, disconnect the electric supply.



Do not clean the machine with compressed air or jet of water.

- Defective parts must be replaced exclusively by expert personnel using the manufacturer's parts.
- Removing or tampering with safety devices is extremely forbidden.



In particular, the Manufacturer shall not be held responsible for complaints deriving from the use of spare parts made by other manufacturers or for damage caused by tampering or removal of safety systems.

8.2 ORDINARY MAINTENANCE

This balancer requires only minor maintenance to keep the machine operating properly.

- Keep the area around the machine clear.
- Keep the display clean and clear. Use a vaporizing cleaner only. Do not use cleaners or the solvents which leave oil or firmly residues behind.
- Keep the adaptors, cones, thread shaft, pressure cup, and the quick locking nut clean. Grease and dirt buildup will cause inaccurate balancing and premature wear. Clean these items at once a day using a vaporizing solvent.
- Clean the weight tray, the cone holders and accessories using a vaporizing solvent. Weights stored in a dirty tray may pick up grease and dirt which may keep them from attaching to the wheel securely.

CHAPTER 9 – ERRORS AND TROUBLE-SHOOTING

9.1 ERROR DISPLAY

During machine operation, various cause of faulty operation can occur. If defected by the micro-processor, they appear on the display as follows:

ERRORS:	MEANING:	SOLUTION:
Err -0-	The machine is not preset up by the manufacturer before delivery.	Call for the technical service.
Err -CAL-	Faulty calibration.	Recalibration.
Err -2-	Speed too low during balancing measurement spin.	Check the driven belt Check the bearings Check the motor Check the quick locking nut tightness
Err -5-	Micro switch is not adjsuted properly or defcetive.	Check and adjust it or replace it if necessary.
Err -6-	The balancing measurement spin is stopped by carelessness.	

9.2 TROUBLE-SHOOTING

TROUBLE:	POSSIBLE CAUSE:	SOLUTION:
No display when switching on	<ol style="list-style-type: none"> 1. There is no power. 2. The faulty power plug. 3. The electrical wires are disconnected. 4. Wrong power voltage. 5. Fuses are blown. 	<ol style="list-style-type: none"> 1. Check power on. 2. Replace. 3. Reconnect. 4. Check for correct voltage. 5. Replace.
The machine does not spin when the wheel guard is closing.	<ol style="list-style-type: none"> 1. The function “start from the guard closing” is not enabled. 2. The wheel guard is not closed completely. 3. The electric wire for the micro switch is disconnected. 4. The micro switch is not adjusted properly or faulty. 	<ol style="list-style-type: none"> 1. Enable the function if necessary. 2. Close the guard completely. 3. Reconnect. 4. Check for correct adjustment or replace it if necessary.
Inconsistent unbalance reading	<ol style="list-style-type: none"> 1. The machine is shocked. 2. The machine is not rested solidly. 3. The wheel is not tightened. 4. Wrong data entry. 5. The machine is not calibrated. 	<ol style="list-style-type: none"> 1. Do not shock the machine and restart a spin. 2. Sit the machine solidly. 3. Tighten the wheel. 4. Entry the correctg data. 5. Calculate the machine.

CHAPTER 10 – ACCESSORIES

10.1 STANDARD ACCESSORIES

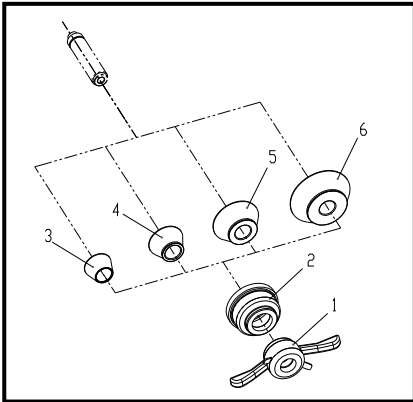

1. TR40X3 Quick locking nut
2. Pressure cup
3. P1-12001W Cone D.44-70
4. P1-12002W Cone D.59-82
5. P1-12003W Cone D.78-111
6. P1-12004W Cone D.85-132

10.2 OPTIONAL ACCESSORIES

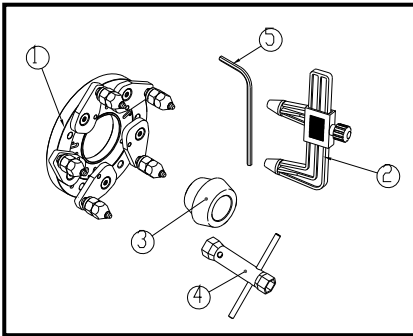

PF-211 Universal flange

Universal flange for wheels with/without central hole, suitable for any vehicle wheel with 3-4-5 holes.

1. Complete flange
2. Holes detector
3. Pre-centering cone
4. T-hexagonal wrench
5. Hexagonal elbowed wrench

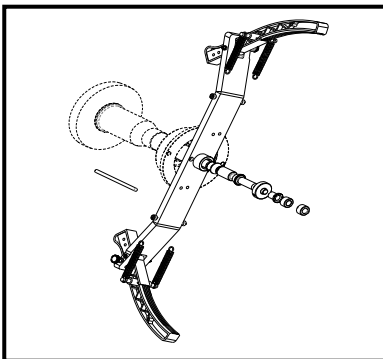

PF-810 Motorcycle adaptor.

1. PF-141 Kit of adaptors
2. P08AG Wheel clamp kit
3. PF-100001 Distance extension

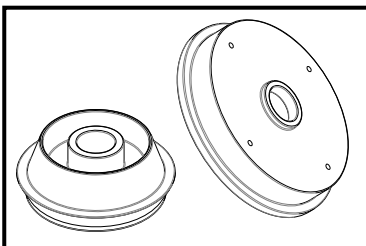

Light truck adaptor

1. PF-221201 Spacer
2. PF-221202 Cone D.111-165

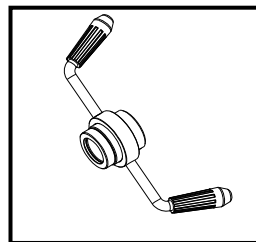

P3-61000

Heavy locking nut